

RADA SENSE - DUAL SHOWER T3



- Buildcert TMV3 Scheme Approved
- WRAS Approved
- Remotely located valve (up to 3m)
- The world's first digital mixing valve for commercial use
- Sets new standards of hygiene
- No-touch ON/OFF and temperature control
- Programmable flow times and temperatures
- Programmable 'duty flushing'
- Thermal disinfection with datalogging
- Valve information and usage data
- Incorporating T-logic™ digital intelligence



Allows the user to operate, communicate and exchange information with the mixing valve to deliver the ultimate in safety, hygiene and control.



Specify as: Rada Sense - Dual Shower T3 (1.1653.030)

Concealed digital mixing valve for dual shower, offering programmable maximum, minimum and default temperatures, duty flush and thermal disinfection with datalogging capabilities. Supplied complete with programmable software, power supply, check valves and strainers. Wall mounted control panel offering infra-red no-touch controls for flow and temperature adjustment and programmable timed flow control.

Dimensions (mm)

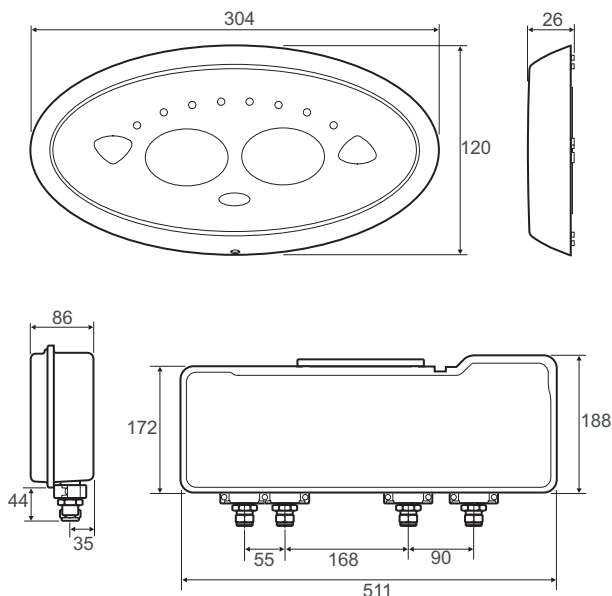

Flow Diagram

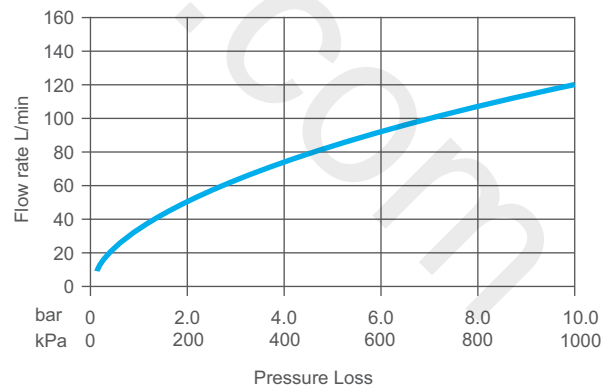

Kohler Mira Limited
 Cromwell Road
 Cheltenham
 Gloucestershire
 GL52 5EP

Specification Enquiries
 Tel: 0844 571 1777
 Fax: 0844 472 3076
 Email: rada_technical@mirashowers.com
 www.radacontrols.com



TECHNICAL SPECIFICATION

Installation and Maintenance

Please refer to the appropriate product manual.

Connections

Inlet: 3/4" BSP male

Outlet: 1/2" BSP male.

Approvals

Buildcert TMV3 Thermostatic Mixing Valve Scheme approved:-

LP-S Low Press. Shower max temp 41°C

HP-S High Press. Shower max temp 41°C

Certificate No. BC100/0205

Complies with the requirements of BS7942 for the same designations

Designed to comply with European Standards EN1111 and EN1287

WRAS approved (Water Regulations Advisory Scheme)

BEAB approved

Designed to IEC 61508

Designed, manufactured and supported in accordance with accredited

BS EN ISO 9001:2008 Quality Management Systems and

BS EN ISO 14001:2004 Environmental Management Systems

Operation

Temperature selector: Full no-touch temperature control.

Flow control: No-touch ON/OFF.

Materials

Control panel cover: Chrome plated ABS.

Mixing unit enclosure: PC/ABS.

Integral components: DZR brass, stainless steel, engineering plastic.

Temperature Range

Factory pre-set: Min 30°C, Max 41°C, Default 38°C.

Programmable range: Min 30°C - 47°C, Max 33°C - 50°C and Default 30°C - 50°C.

Minimum blend temperature differential from hot supply: 2°C.

Optimum thermostatic control range: 30°C - 50°C.

Cold water range (recommended): 1°C - 20°C.

Hot water range (recommended): 50°C - 65°C (85°C during disinfection).

Temperature stability: $\pm 1^\circ\text{C}$ for recommended supply conditions.

Pressures

Maximum static pressure: 10 bar (1000 kPa).

Minimum pressure loss: 0.2 bar (20 kPa) Refer to Note.

Hot and cold pressure should be nominally equal.

(Max differential 3:1 either way).

Minimum flow rate: 9 l/min.

Note! The pressure loss of a system (valve and outlet fitting) is the average of the two inlet pressures minus the back pressure, where the back pressure is determined by the flow resistance of any outlet fitting.

Environment

Ambient temperature: 1°C - 40°C.

Maximum relative humidity: 95% non-condensing.

Note! Certain types of compact fluorescent and low voltage lighting use high frequency lamps that can interfere with the infrared system used in the control panel. Install in areas where standard switch-start fluorescent lighting is used.

IP Rating

Control panel: IP47

Overall valve enclosure: IP24

Electronics compartment: IP45

PSU: IP45.

Electrical Specification

Supply Voltage: 100 - 240 V RMS 50 - 60 HZ.

Maximum load: 20 W at 12 V DC.

Control panel cable length: 3 m supplied (6 m max).

Times (Duty flush not enabled at factory, programming required)

Factory settings

Flow time: 30 sec

Duty flush cycle: 2 minutes.

Duty flush waiting period: 12 hours.

Programmable range

Flow time: 5 sec - 60 min.

Duty flush cycle: 1 min - 59 min.

Duty flush waiting period: 1 hr - 983 hrs.

Disinfection not enabled at factory.

Disinfection

Factory settings

Minimum temperature: 60°C.

Minimum time: 5 minutes.

Programmable range

Minimum temperature: 60°C - 85°C.

Minimum time: 0 - 50 minutes.

Pocket PC (PDA*)

A Pocket PC is required to adjust factory settings, retrieve data, configure duty flush and disinfection cycles.

The programmer software supplied is designed to run on Microsoft Pocket PC 2002 and Microsoft Windows Mobile (for Pocket PC).

* Personal Digital Assistant (not supplied)

Please refer to the appropriate software manual.

Kohler Mira Limited
Cromwell Road, Cheltenham
Gloucestershire, GL52 5EP

Specification Enquiries

Tel: 0844 571 1777, Fax: 0844 472 3076
Email: rada_technical@mirashowers.com
www.radacontrols.com

Rada is a registered trademark of Kohler Mira Limited.

The company reserves the right to alter product specification without notice.

© January 2012 Kohler Mira Limited. All rights reserved.

No part of this document, or any accompanying document, may be reproduced or transmitted in any form or by any means, including photocopying or electronically, without the permission of Kohler Mira Limited.

A **KOHLER** COMPANY



FM 14648

