

Mira Platinum & Vision

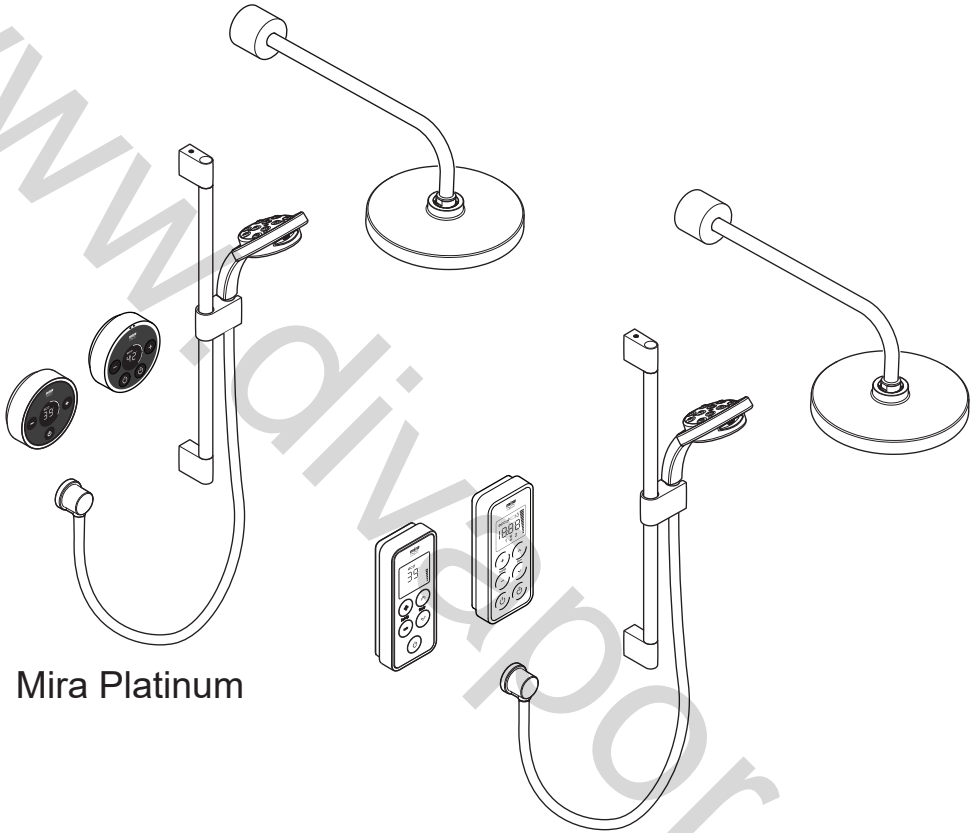

Mira Platinum

Mira Vision

These instructions must be left with the user

Installation Guide

Showering perfection

mira
SHOWERS

CONTENTS

Introduction	3
Products Covered by this Guide.....	3
Guarantee	3
Patents and Design Registration.....	3
Safety Information	4
Pack Contents	6
Specifications	12
Standards and Approvals	12
Dimensions	14
Installation	17
General Information.....	17
Important Information Regarding Radio Controlled Devices	17
Installation Schematic (Single Outlet)	22
Installation Schematic (Dual Outlet).....	23
Valve Installation Orientation.....	24
Position and Signal Test.....	25
Shower Fittings - Ceiling Fed	28
Shower Fittings - Rear Fed	34
Wireless Controller	41
Commissioning	42
Connecting a Second Wireless Controller	44
Re-Registering	45
Fault Diagnosis	46
Maintenance	54
Spare Parts	55
Disposal and Recycling	62
Customer Service	Back Page

If you experience any difficulty with the installation or operation of your new shower, then please refer to the **Fault Diagnosis** section, before contacting **Kohler Mira Ltd.**
Our telephone and fax numbers can be found in the back of this guide.

INTRODUCTION

Thank you for purchasing a quality Mira product. To enjoy the full potential of your new product, please take time to read this guide thoroughly. Having done so, keep it handy for future reference.

The Mira Platinum & Vision Mixer Valve are designed to be used with the Mira showerhead and fittings.

Products Covered by this Guide

Mira Platinum and Vision Digital Mixer - High Pressure/Combi Valve

Mira Platinum and Vision Digital Mixer - Pumped Valve.

Mira Platinum & Vision Wireless Controller.

Mira 360 Fittings (Ceiling Fed or Rear Fed).

Guarantee

This product has been designed for domestic use only, it is not recommended for Commercial or Healthcare use.

For domestic installations, Kohler Mira Limited, guarantee this product against any defect in materials or workmanship for a period of five years from the date of purchase (shower fittings for one year).

Recommended Usage	
Domestic	✓
Light Commercial	✗
Heavy Commercial	✗
Healthcare	✗

Patents and Design Registration		
Product	Mira Platinum	Mira Vision
Design Registration	001065023-0003	001295935
Patents	GB: 2 392 225, 2 421 297 USA: 7 240 850	GB: 2 421 297 USA: 7 669 776
Patent Applications	UK: 0723827.2 0715612.8 0804172.5 Euro: 03254070.0 USA: US-2007-0221740-A1 PCT/GB2008/004020 WO 2009/022112	WO: 2009/022112 Euro: 2 227 647 USA: US-2010 - 0282 326 - A1 CHINA: CNI01918743A INDIA: 1306/MUMNP/2010

SAFETY INFORMATION

Products manufactured by Kohler Mira Ltd are designed to be safe, provided that they are installed, used and maintained in good working order, in accordance with our instructions and recommendations. Follow all warnings, cautions and instructions contained in this guide, and on, or inside the product. **Failure to follow the instructions provided with this product will invalidate the guarantee.**

Warning! To reduce the risk of fire, electric shock or injury please read the important information listed below.

1. Installation of this product must be carried out in accordance with these instructions by qualified, competent personnel. **Read all instructions before commencing installation.**
2. The electrical installation must comply with BS 7671 (commonly referred to as the IEE Wiring Regulations) and all relevant building regulations, or any particular regulation or practice specified by the local electricity supply company.
3. The plumbing installation must comply with all national or local water regulations and all relevant building regulations, or any particular regulation or practice specified by the local water supply company.
4. Isolate the electrical and water supplies before commencing installation. Mains connections are exposed when the valve module cover is removed.
5. The valve module must be earthed, ensure supplementary bonding is provided in accordance with the wiring regulations.
6. This product must be permanently connected to a 3A fused connection unit and be provided with means for disconnection incorporated in the fixed wiring in accordance with the wiring regulations.
7. We strongly recommend that a 30mA RCD is included in the electrical supply to this product.
8. **DO NOT** install this product, user interface or the remote on/off control in areas with high humidity and temperature (i.e. steam rooms and saunas).
9. **DO NOT** install this product or fittings where they may be exposed to freezing conditions. Ensure that any pipework that could become frozen is properly insulated.
10. **DO NOT** perform any unspecified modifications, drill or cut holes in the product other than instructed by this guide. When servicing only use genuine Kohler Mira replacement parts.

11. **DO NOT** operate the product if water is leaking from inside the valve module. Isolate electrical and water supplies to the product and refer to the fault diagnosis section.
12. **DO NOT** apply power to the product if it is thought to have been exposed to freezing conditions. Isolate electrical and water supplies to the product and contact Kohler Mira Ltd.
13. **DO NOT** allow children to play with the product.
14. **DO NOT** allow children to clean or perform any user maintenance without supervision.
15. **DO NOT** remotely operate or alter any of this products shower and bathing settings if it is already occupied and / or being used by another person.
16. If the product is dismantled during installation or servicing then, upon completion, an inspection must be made to ensure all electrical connections are secure and that there are no leaks.
17. Make sure that you fully understand how to operate the product and make sure that it is properly maintained in accordance with the instructions given in this manual.
18. This product can be used by children aged from 8 years and above and persons with reduced physical, sensory or mental capabilities or lack of experience and knowledge if they have been given supervision or instruction concerning the use of the product in a safe way and understand the hazards involved.
19. Always check the water temperature is safe before bathing or showering.
20. **DO NOT** use excessive force when making connections.
21. Avoid layouts where the shower hose will be sharply kinked. This may reduce the life of the hose.
22. Special consideration should be given to the fixing arrangements when installing onto a dry lined, stud partition, shower cubicle or laminated panel wall structures. Installers may wish to obtain alternative proprietary cavity fixings, or choose other options, however, these methods of fixing are beyond the scope of this guide.
23. The position of the shower fittings must provide a minimum air gap of 25mm between the handshower and the spill over level of any bath, shower tray or basin. There must be a minimum distance of 30mm between the handshower and the spill over level of any toilet, bidet or other appliance with a Fluid Category 5 backflow risk.
24. When installing the product to be used as a bath filler ensure the flow rate of the bath overflow fitted exceeds the flow rate output from the product.

PACK CONTENTS

Tick the appropriate boxes to familiarise yourself with the part names and to confirm that the parts are included.

Documentation

- 1 x Wireless Controller User Guide
 1 x Customer Support Brochure
 1 x Showerhead User Guide

Digital Mixer Valve

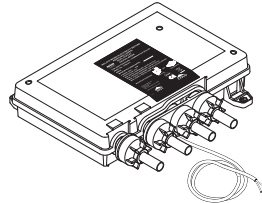
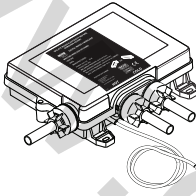

- Single or Dual Outlet - High Pressure / Combi Valve
OR

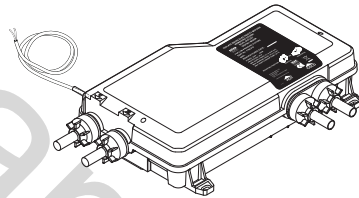
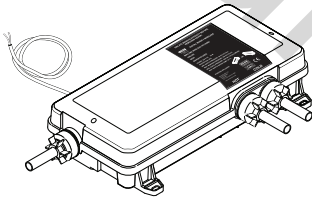

- Single or Dual Outlet - Pumped Valve for Gravity



- 3 x Fixing Screws



- 3 x Fixing Screws



- 3 x Wall Plugs



- 3 x Wall Plugs



- 2 x Push-Fit Isolators



- 2 x Push-Fit Isolators



- 1 x Outlet Connector



- 2 x Outlet Connector

Mira Platinum Wireless Controller

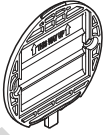

1 x Backplate

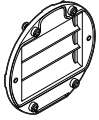

1 x Battery Cover



OR

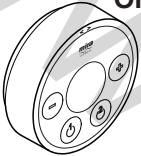

1 x Wireless Controller
(Single Outlet)

1 x Wireless Controller
(Dual Outlet)



2 x Fixing Screws



2 x Wall Plugs



3 x AA Batteries

Mira Vision Wireless Controller

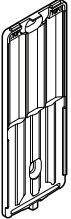

1 x Backplate



1 x Battery Cover

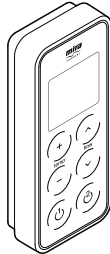

OR

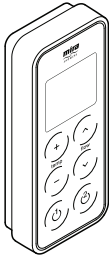

1 x Wireless Controller
(Single Outlet)

1 x Wireless Controller
(Dual Outlet)



2 x Fixing Screws



2 x Wall Plugs



3 x AA Batteries

Single Outlet - Ceiling Fed Fittings

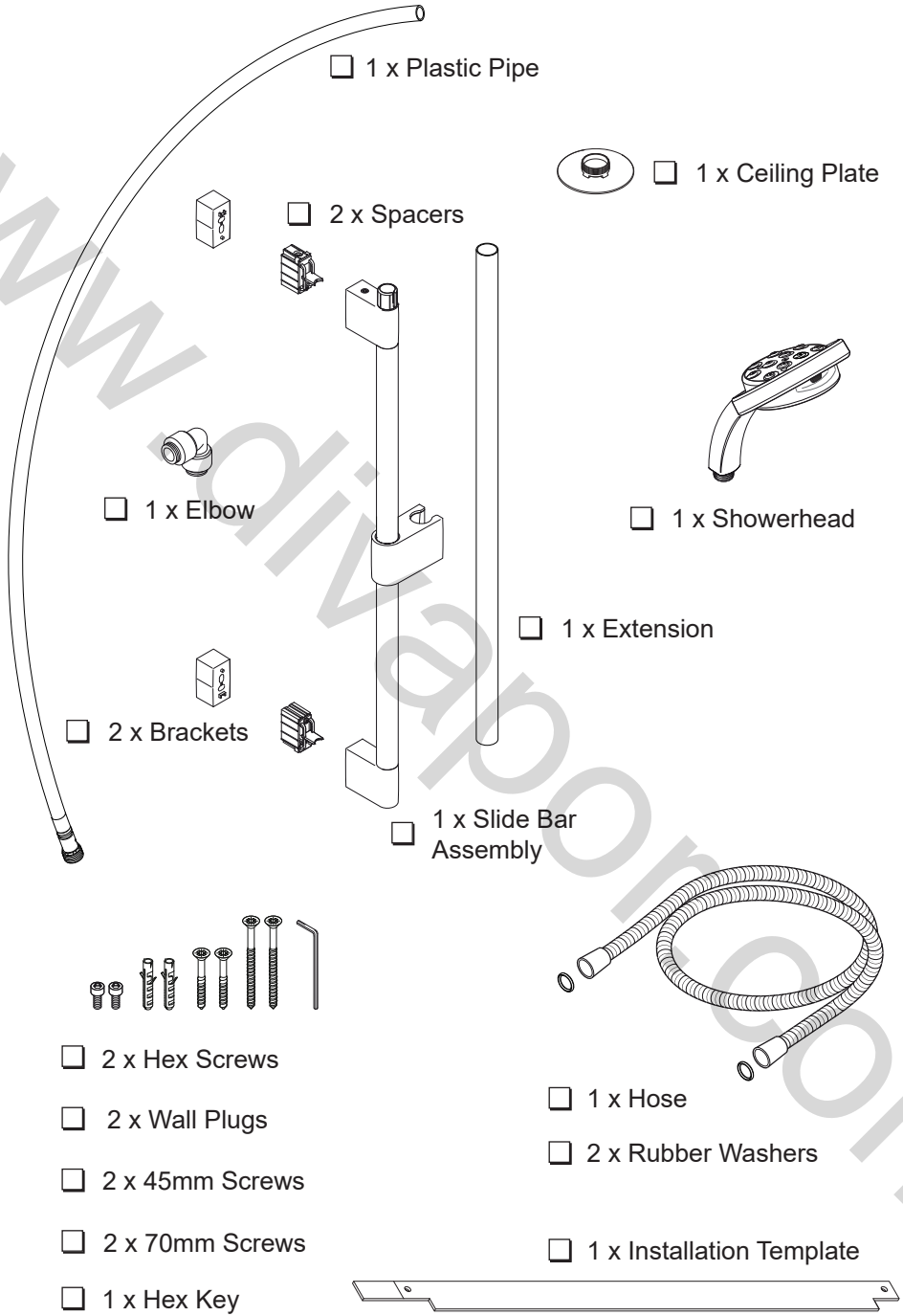

Single Outlet - Rear Fed Fittings

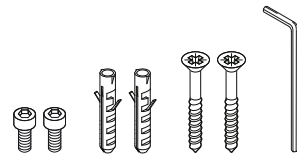
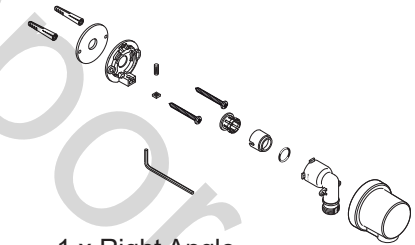
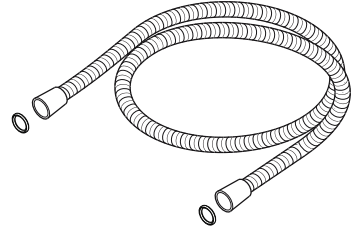
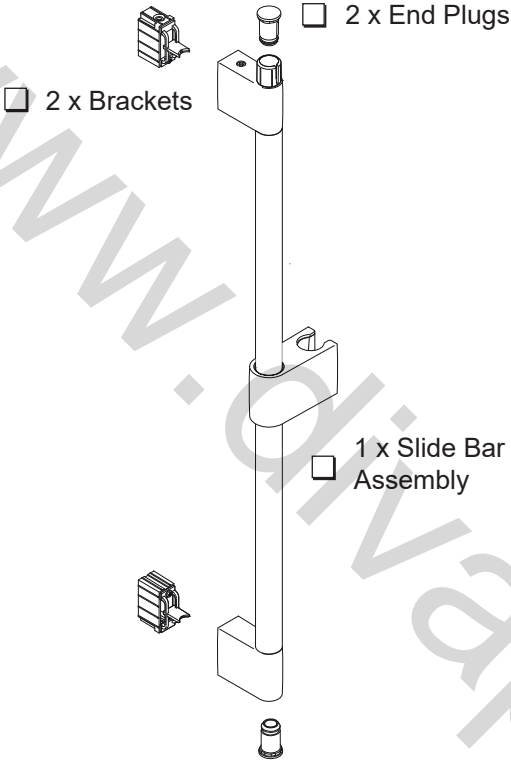

Dual Outlet - Ceiling Fed Fittings

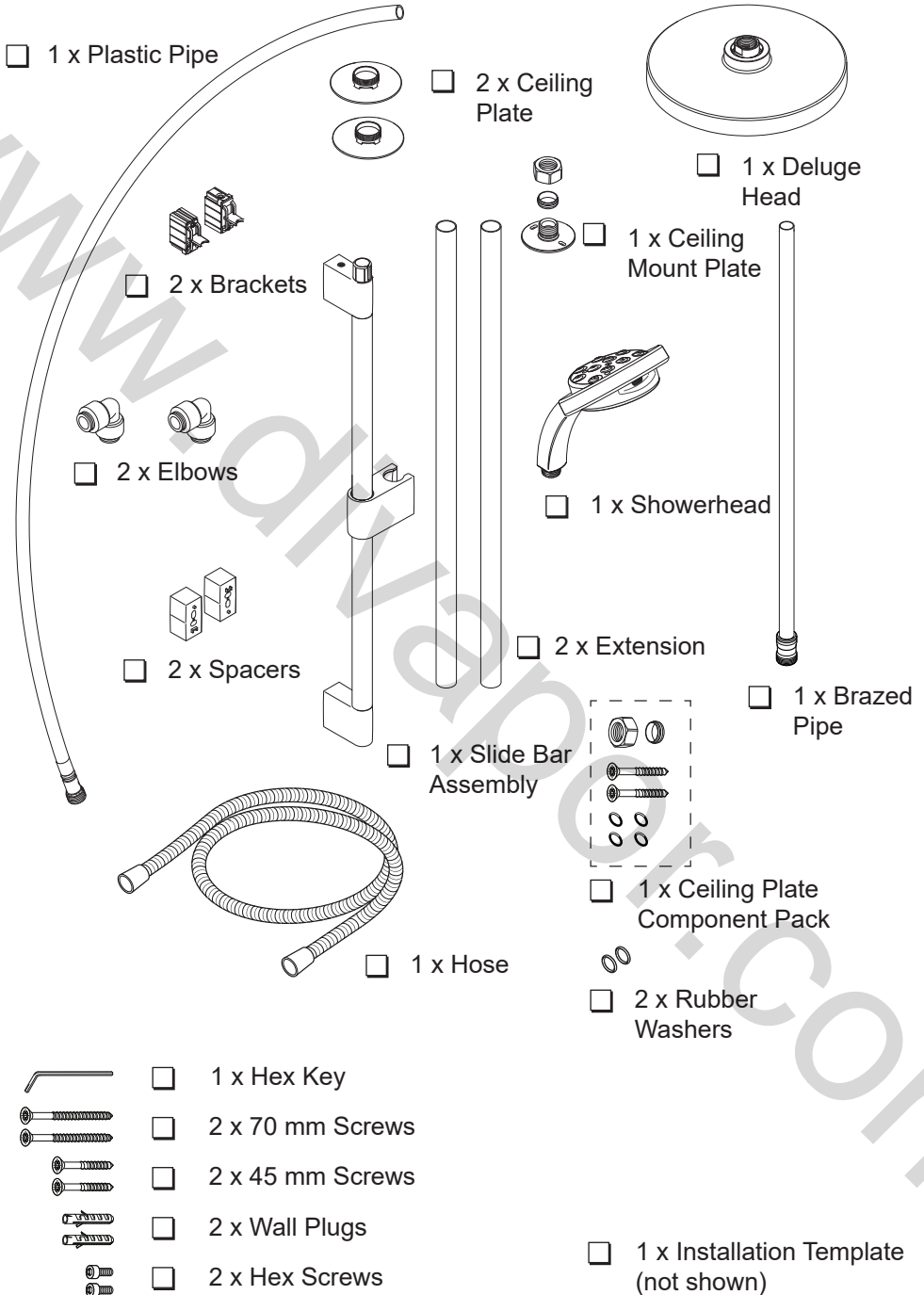

Dual Outlet - Rear Fed Fittings

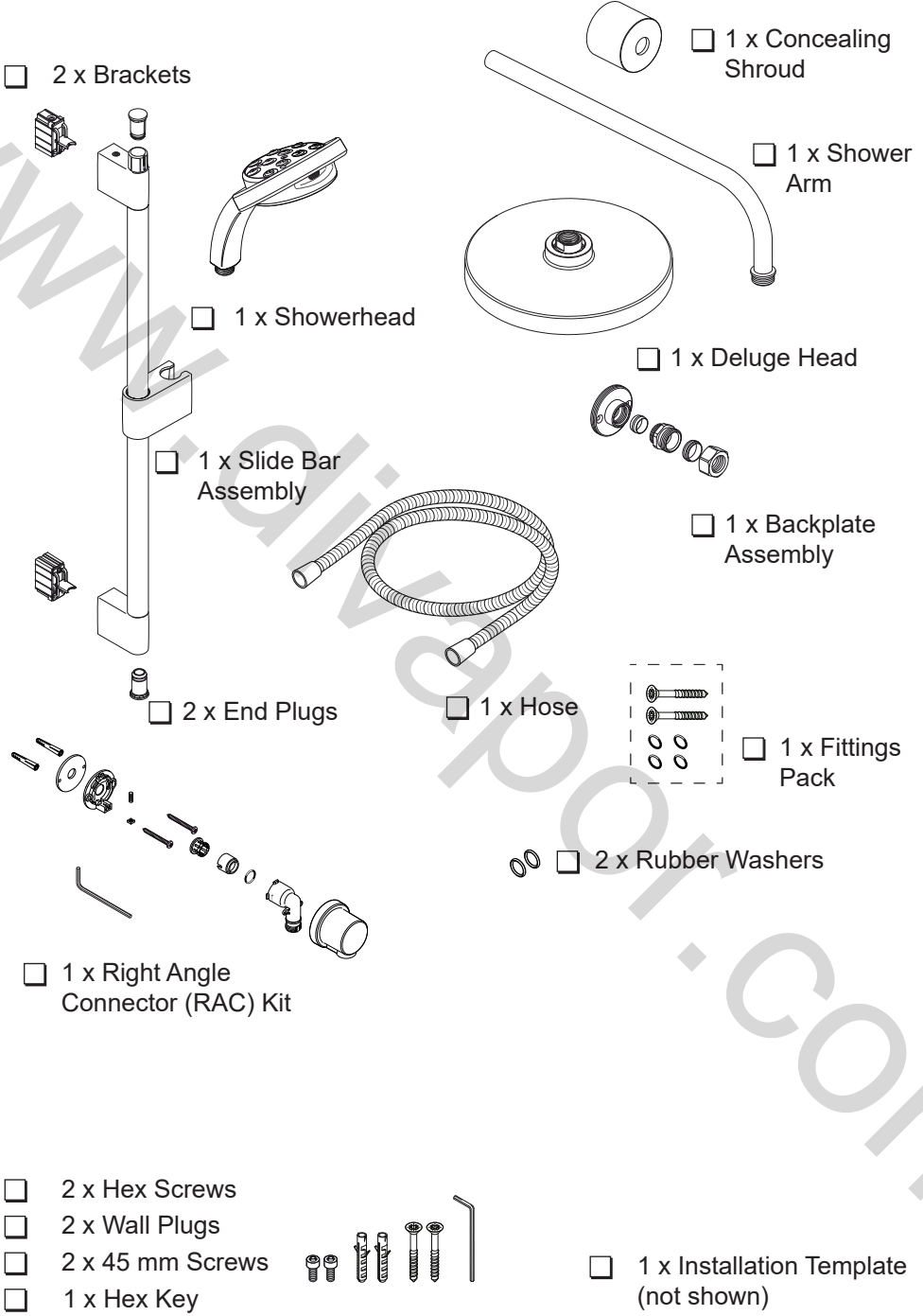

SPECIFICATIONS

Standards and Approvals

The Mira Platinum & Mira Vision complies with all relevant directives for CE marking. The Mira Platinum is a type 1 electronic, independently mounted control for surface mounting.

Hereby, Kohler Mira Ltd. declares that the radio equipment type Platinum & Vision is in compliance with Directive 2014/53/EU. The full text of the EU declaration of conformity is available at the following internet address: www.mirashowers.co.uk.

The Platinum and Vision operates in the Frequency band 400-464MHz with a maximum power of +7dBm.

General

Pollution Degree	2
Rated Impulse Voltage	2.5 kV
Suitable for Drinking	Not Suitable
Connections	15 mm Compression/Pushfit

Mira Digital Mixer Valve High Pressure (Not suitable for Pumped Gravity Systems)

Pressures	
Maximum Static Pressure	1000 kPa (10 bar) = 100 m max. total head
Maximum Maintained Pressure	500 kPa (5 bar) = 50 m max. total head
Minimum Maintained Pressure	100 kPa (1.0 bar) = 10 m min. total head
Supply Pressure Differential	Nominally Equal
Temperatures	
Maximum Temperature (factory preset)	45 °C
Maximum Temperature (setting range)	35 °C - 48 °C
Minimum Temperature	Thermostatic control down to 30 °C Full cold also selectable
Hot Water Range	55 °C - 65 °C
Cold Water Range	1 °C - 20 °C
Temperature Stability	± 1 °C at recommended supply conditions
Ambient Temperature	1 °C - 40 °C
Maximum Relative Humidity	95% non-condensing
Flow Rates	
Nominal Flow Rates (will vary depending on inlet maintained pressure and spray mode)	Max @ 1.0 bar = 12 l/min Min @ 1.0 bar = 5 l/min
Electrical	
Supply Voltage	230V AC 50 Hz
Maximum Load	20 W

Mira Digital Mixer Valve Pumped

Pressures	
Maximum Static Pressure	100 kPa (1 bar) = 10 m max. total head
Maximum Maintained Pressure	100 kPa (1 bar) = 10 m max. total head
Minimum Maintained Pressure	1 kPa (0.01 bar) = 0.1 m min. total head
Supply Pressure Differential	Nominally Equal
Temperatures	
Maximum Temperature (factory preset)	45 °C
Maximum Temperature (settable range)	35 °C - 48 °C
Minimum Temperature	Thermostatic control down to 30 °C Full Cold also selectable
Hot Water Range	55°C - 65°C
Cold Water Range	1°C - 20°C
Temperature Stability	± 1°C at recommended supply conditions
Ambient Temperature	1°C - 40°C
Maximum Relative Humidity	95% non-condensing at 30 °C
Flow Rates	
Flow Rates (will vary depending on inlet maintained pressure and spray mode)	Max @ 0.01 bar = 12 l/min Min @ 0.01 bar = 6 l/min
Electrical	
Supply Voltage	230V AC 50 Hz
Maximum Load	200 W at 230V AC

DIMENSIONS

Mira Platinum & Vision - Single Outlet

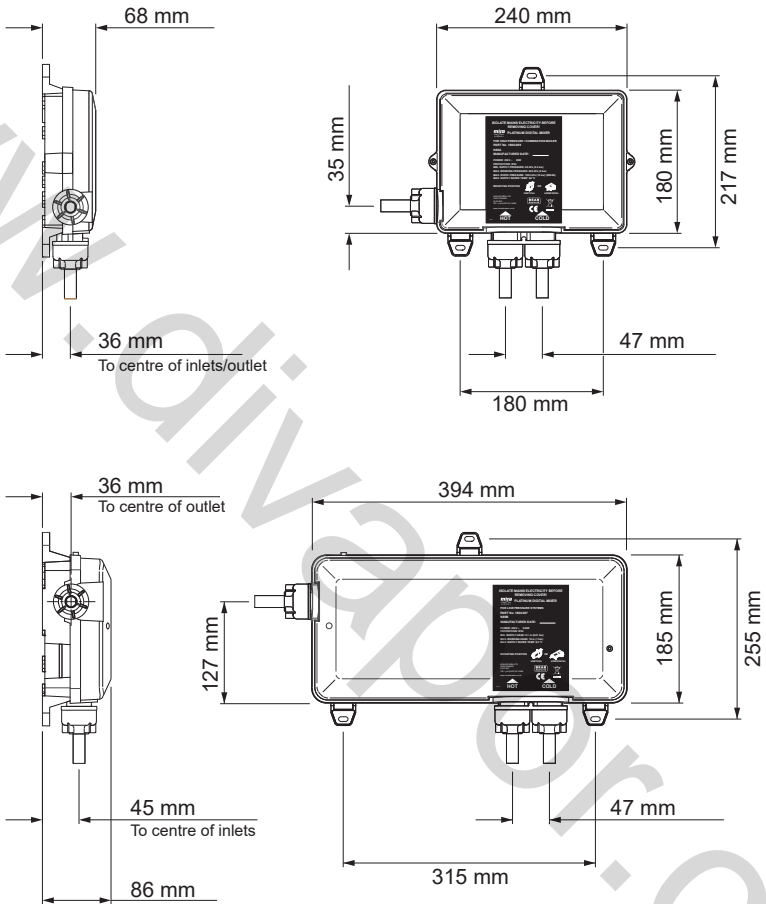

Mira Platinum & Vision - Dual Outlet

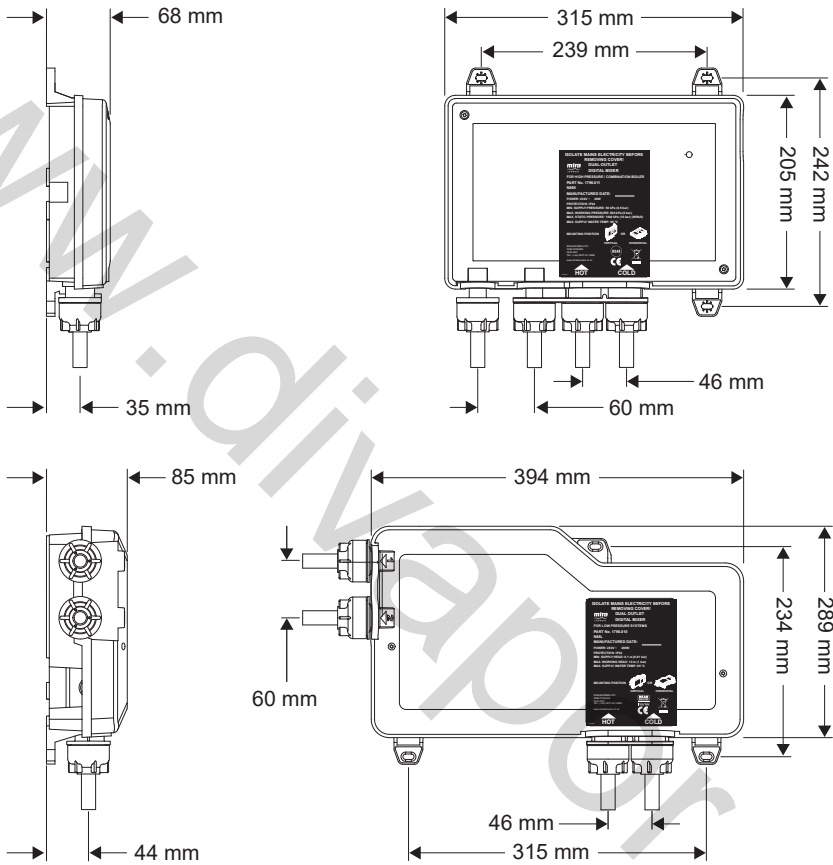

Shower Fittings

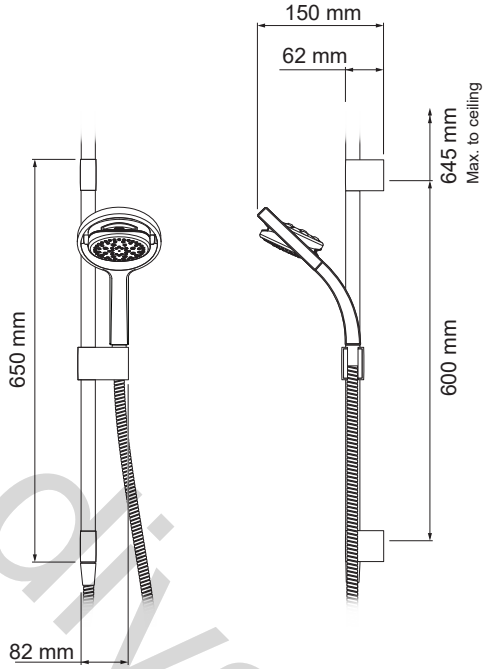

Shower Fittings - Fixed Rear Fed Arm

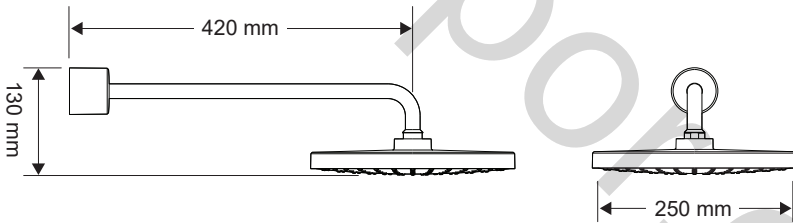

Shower Fittings - Ceiling Fed Arm

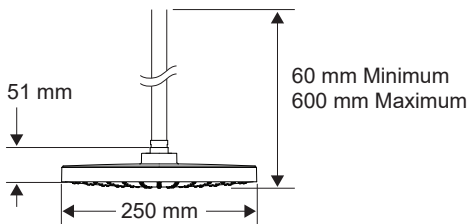

INSTALLATION

General Information

The product may be installed in a loft space, under the bath or in a convenient cupboard space, provided there is enough room for maintenance (e.g. Removal of the product lid). Failure to do so may result in an inability to carry out any maintenance.

Safe and easy access to the product should be available at all times.

When installing the product in an area not regularly accessed, consideration for potential leaks must be taken into account. While such events are unlikely, it is advisable to periodically check the installation for traces of water on or around the product.

If possible, site the product in a location where any leak would be contained or routed to avoid areas sensitive to water damage.

Inlet isolating valves (supplied) must be installed.

We strongly recommend that full bore outlet isolation valves are fitted as close to the product as possible for ease of service and maintenance.

The water supplies to this product must be isolated if the product is not to be used for a long period of time. If the product or pipework is at risk of freezing during this period they should also be drained of water.

Important Information Regarding Radio Controlled Devices

- Metal objects such as steel baths or sinks, cold water storage tanks, hot water cylinders, foil lined plaster board walls, radiators and even thick brick walls, can all dramatically reduce the radio operational range of any radio controlled product.
- Interference from other radio signals can dramatically reduce the ability of the Wireless Controller / digital mixer to register or communicate. This may include; mobile phones, radio control boiler thermostats, wireless broadband routers, radio control toys, cordless phones, remote outdoor weather stations, wireless doorbells etc.
- If you encounter difficulty registering the wireless controller and digital mixer ensure all other radio interference is temporarily switched off.

Note: Failure to follow these guidelines can result in poor, intermittent or complete failure to communicate with the digital mixer.

Typical Suitable Installations:

1. Instantaneous Multipoint Water Heaters and Combination Boilers

Caution! Risk of product damage. Do not fit the Mira Digital Mixer - PUMPED VALVE with Instantaneous Multipoint Water Heaters or Combination Boilers.

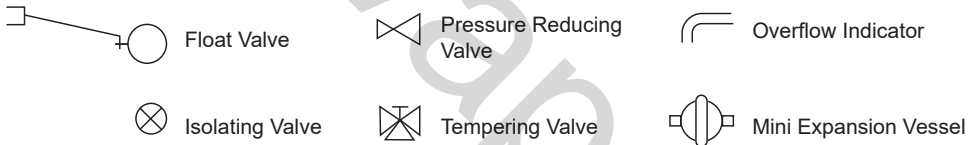
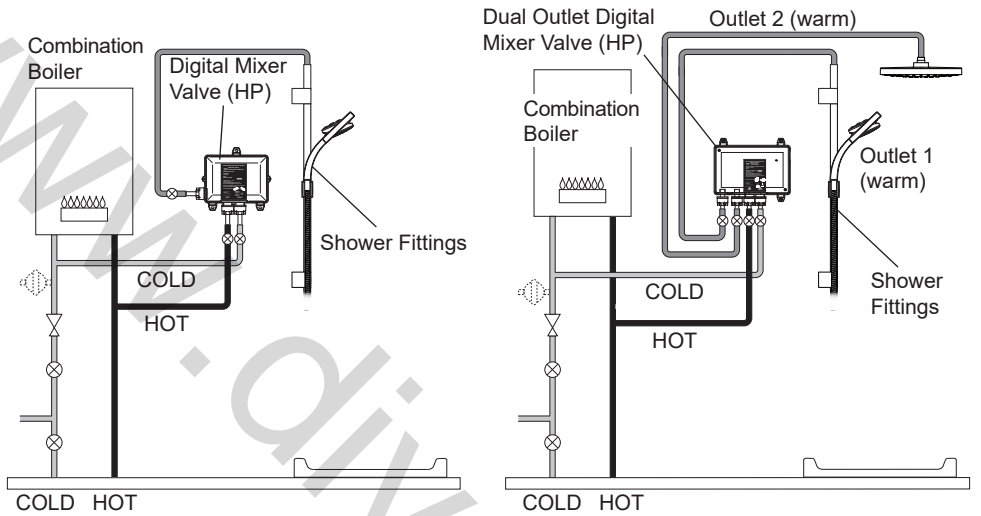

Key to Symbols

Only install the High Pressure Digital Mixer Valve with a multipoint gas water heater or combination boiler of a **fully modulating design** (i.e. where the water draw-off rate indirectly controls the gas flow rate to the burner).

An expansion vessel **must** be fitted (and regularly maintained) if any form of backflow prevention device is fitted, e.g. Non-return valve or PRV. This will ensure that excess expansion or pulse pressures do not damage the product or plumbing system. The expansion vessel may already be fitted within the boiler (check with the manufacturer) and is in addition to the normally larger central heating expansion vessel.

Use of Warm-up Feature with Combination Boilers

When using the warm-up feature (see User Guide) with the digital mixer valve supplied via an instantaneous water heater/combination boiler, the user may experience a brief temperature fluctuation. This is caused by the normal operation of a standard instantaneous water heater/combination boiler whereby the boiler will turn off when the flow is stopped (as happens after the warm-up sequence has been completed). Upon restart of the shower, a cold shot will be flushed through followed by a brief hot shot until the hot water supply has stabilised.

2. Mains Pressurised Instantaneous Hot Water Shower, Heated from a Thermal Store

Caution! Risk of product damage. Do not fit the Mira Digital Mixer - PUMPED VALVE with Mains Pressurised Systems.

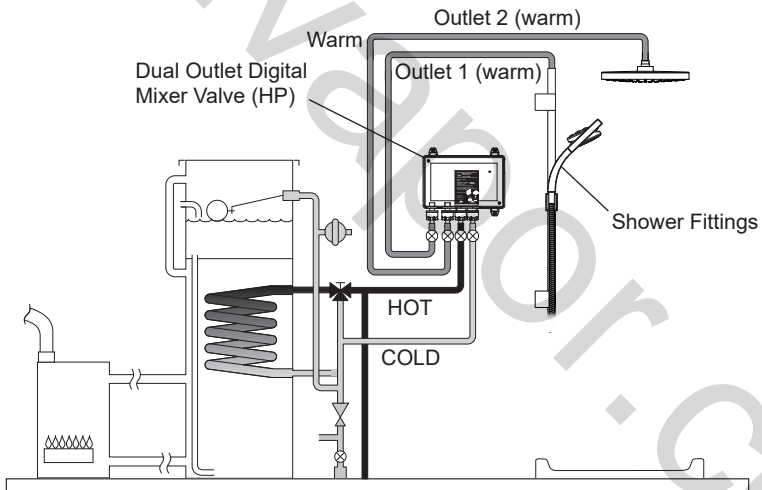
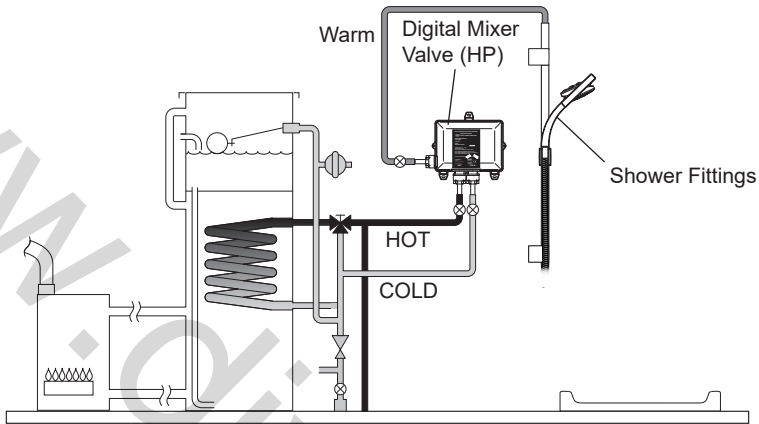

Packages of this type, fitted with a tempering valve can be used. A drop type pressure reducing valve **must** be fitted (and regularly maintained) if any form of backflow prevention device is fitted, e.g. non-return valve, PRV, then an expansion vessel should also be fitted. This will ensure that excess expansion or pulse pressures do not damage the product or the plumbing system. The expansion vessel may already be fitted externally or internally within the thermal store (check with thermal store manufacturer).

3. Gravity Fed Showers

Caution! Risk of product damage. Do not fit the Mira Digital Mixer - HIGH PRESSURE/COMBI VALVE with Gravity Fed Systems.

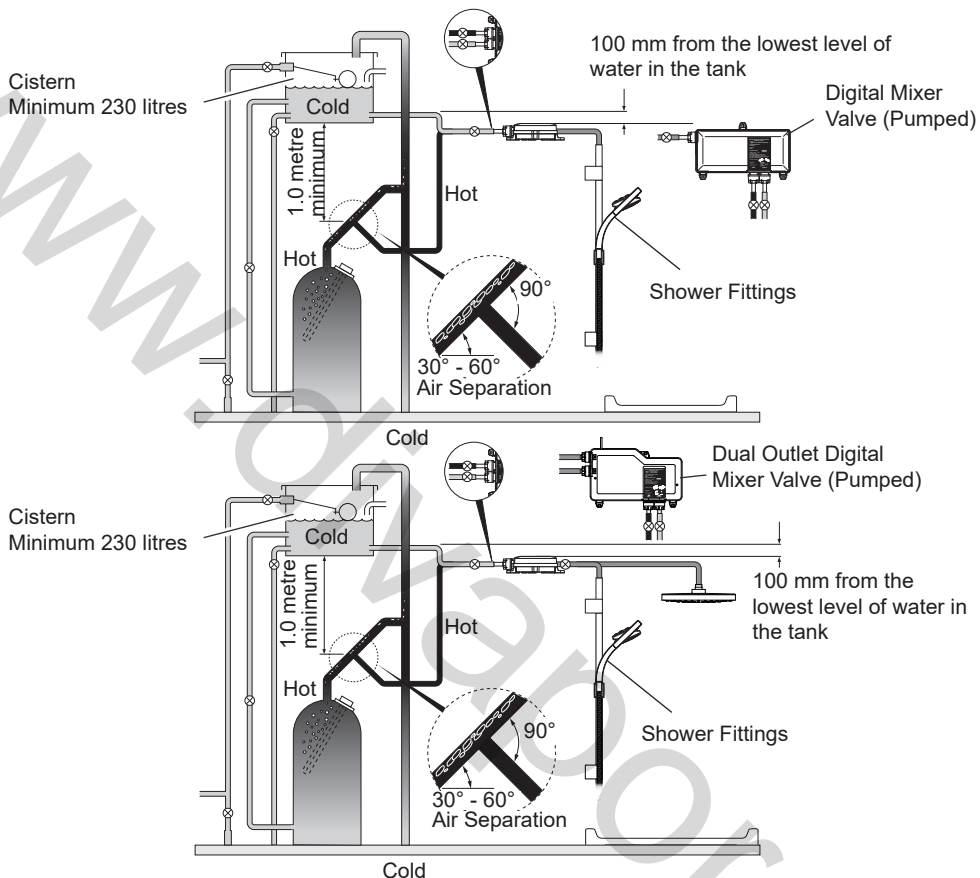

The shower control **must** be fed from a **cold water storage cistern** and a **hot water cylinder** providing nominally equal pressures. Pipework layouts and connections **must** be such that other draw-offs will not effect water supplies to the shower, shared supplies may lead to airlocking or water starvation. It is therefore best practice to have independent hot and cold supplies to the Low Pressure (pumped) Digital Mixer Valve.

Note: A gravity fed Hot Water Cylinder has a finite amount of stored hot water. A standard size Hot Water Cylinder, e.g. 230 Litres, with stored water heated to 65°C will typically provide a showering duration of 30 minutes when the shower temperature is set to mid-blend (approximately 40°C) and at a flow rate of 9 l/min. Increasing the showering flow rate to 12 l/min will reduce the total showering duration to typically 20 minutes.

Once the stored hot water has been depleted sufficient time will be required for the Hot Water Cylinder to reheat its stored water supply before additional showering time can take place.

Use of Flow Regulators with Combination Boilers

The Mira High Pressure / Combi digital mixing valve can demand hot water quicker than some instantaneous water heaters/combination boilers can provide, especially in winter when the mains water is colder. A Hot inlet flow regulator may need to be used to ensure that the Digital Mixer Valve can deliver a full range of water temperatures.

Note:

The Mira **Single** outlet High Pressure / Combi digital mixing valves are factory fitted with an 8 l/min hot inlet flow regulator. If installing a single outlet digital mixer with a combi boiler rated 36kW or greater or to mains pressurised systems the hot inlet flow regulator should be removed.

Note:

The Mira **Dual** outlet High Pressure / Combi digital mixing valves do not have a factory fitted hot inlet flow regulator. These are supplied in the component pack. The table indicates which flow regulator should be fitted in the hot water inlet of the Mira Digital Mixer Valve if installing to a combination boiler system.

Boiler Rating	24 kW (80,000 Btu/h)	30 kW (100,000 Btu/h)	36 kW (120,000 Btu/h)
Flow Regulator	7 litres/min	9 litres/min	Not required
Colour	White/Green	White/Orange	-

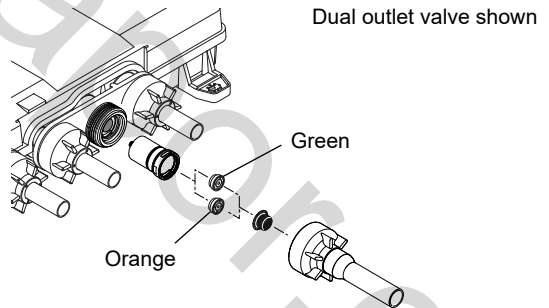
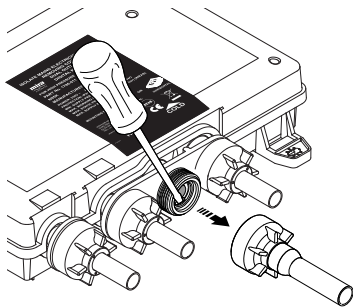

- ▶ Unscrew hot inlet plastic nuts and remove pipe and seal to gain access to the checkvalve cartridge and filter.
- ▶ Use flat blade screwdriver to carefully lever cartridge out.
- ▶ Fit/remove the flow regulator from checkvalve cartridge behind filter as required.
- ▶ Refit seal, pipe and plastic nut. Plastic nuts require hand tightening only.

Typical Examples of Poor Plumbing and Installation Practices DO NOT:

- Install the Digital Mixer Valve where it can become frozen
- Install the Digital Mixer Valve where it can be subjected to ambient temperatures in excess of 40°C
- Position the Digital Mixer Valve where maintenance access is poor or unsafe
- Install into a system where the cold water cistern holds less than 230 litres
- Install into a system where air locking could occur
- Install the wireless controller in a position where communication with the Digital Mixer Valve is poor e.g. mixer valve installed under metal bath, in front of metal cistern, on foil backed plasterboard, more than the recommended distance away etc.
- Install the Digital Mixer Valve onto shared water supplies
- Install the Digital Mixer Valve less than 100 mm from the lowest level of water in the cistern (low pressure version only)
- Fit plastic pipework unless rigidly supported
- Install a High Pressure/Combi Valve to a Pumped Gravity System

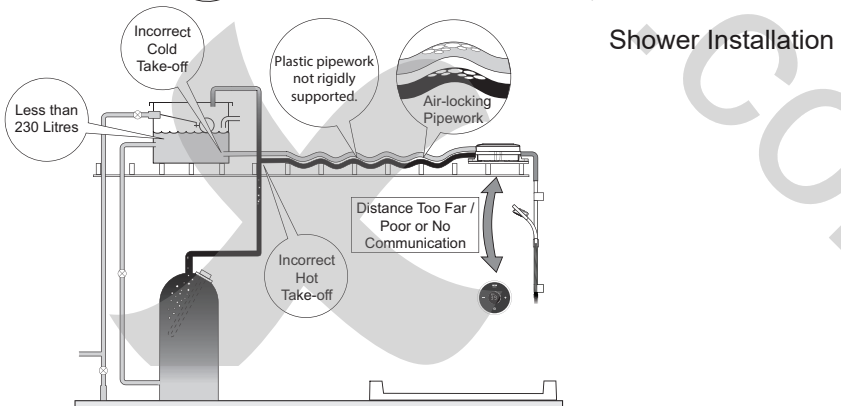
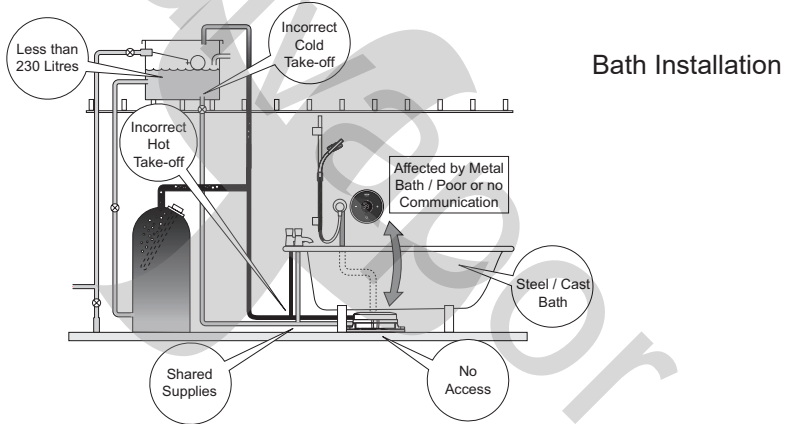

Installation Schematic (Single Outlet)

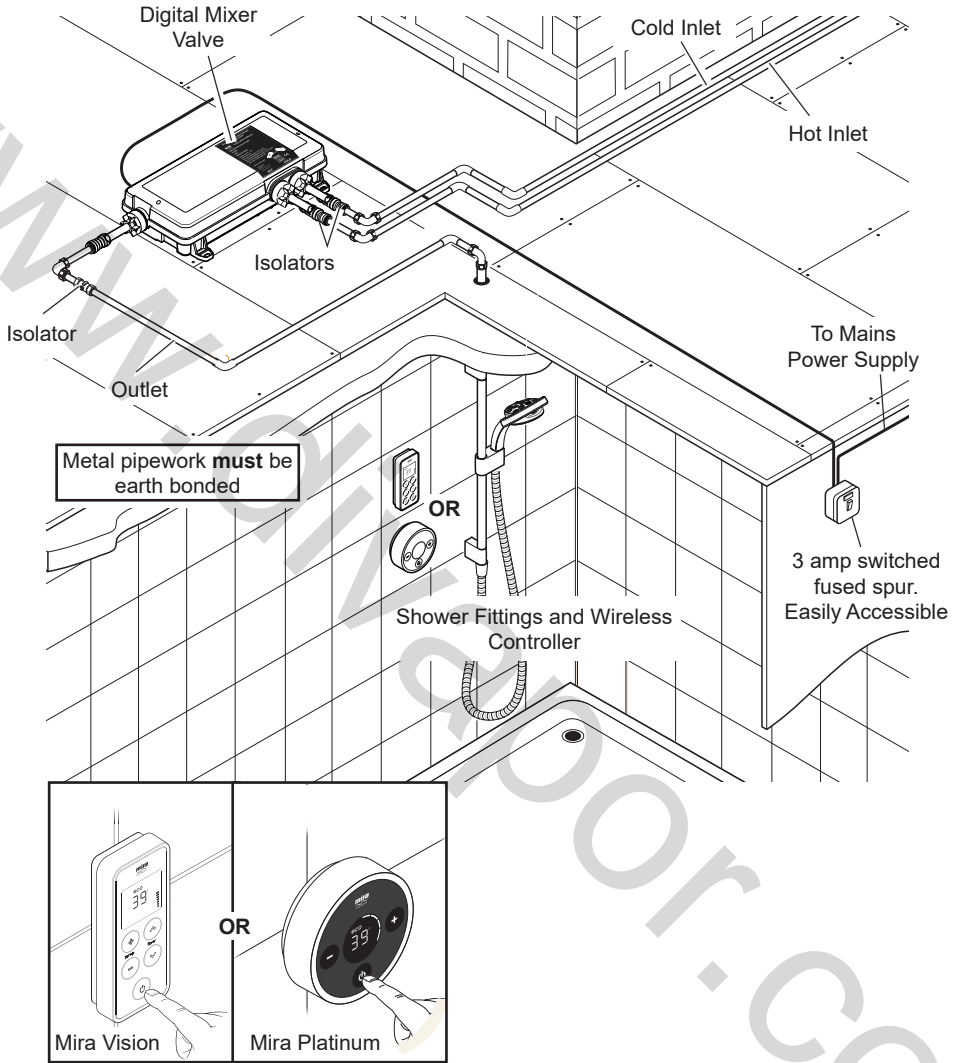

Installation Schematic (Dual Outlet)

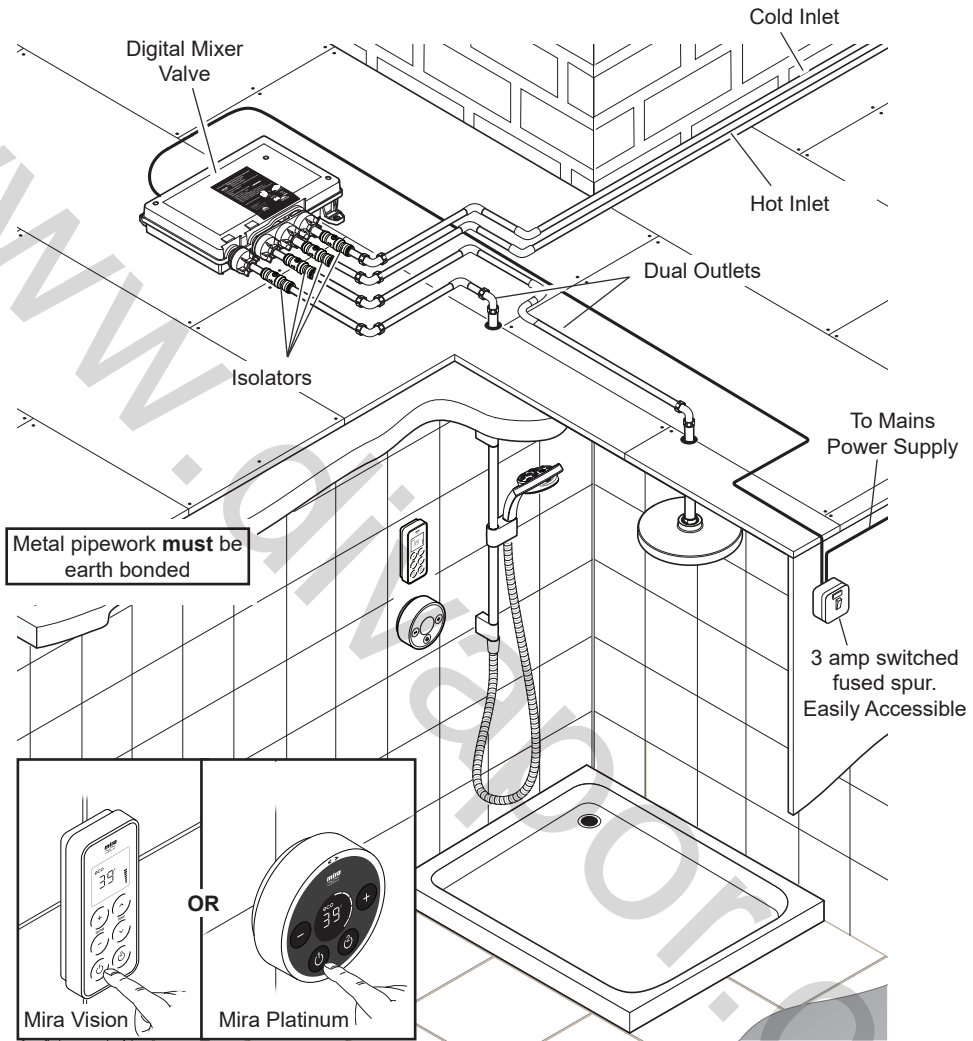

- ▶ A separate, permanently connected supply **must** be taken from the ring main to the appliance through a **3 amp** double pole switched fused spur providing a minimum 3mm contact separation gap in each pole.
- ▶ Ensure the switched fused spur is easily accessible for serviceable and resetting purposes.
- ▶ The use of supply-line or zone strainers will reduce the need to remove debris at the Digital Mixer Valve. The recommended maximum mesh aperture dimension for such strainers is 0.5 mm.

- ▶ Pipework **must** be rigidly supported to avoid any strain on the connections.
- ▶ A 30 mA Residual Current Device (RCD) **must** be included in the electrical circuit. This may be part of the consumer unit or a separate unit.
- ▶ Long inlet pipework (dead-legs) should be kept to a minimum to avoid temperature fluctuations.
- ▶ Supply pipework layout must be arranged to minimize the effect of other outlet usage upon the dynamic pressures at the Digital Mixer Valve inlets.
- ▶ To eliminate pipe debris it is essential that supply pipes are thoroughly flushed through before connection to the Digital Mixer Valve.

Valve Installation Orientation

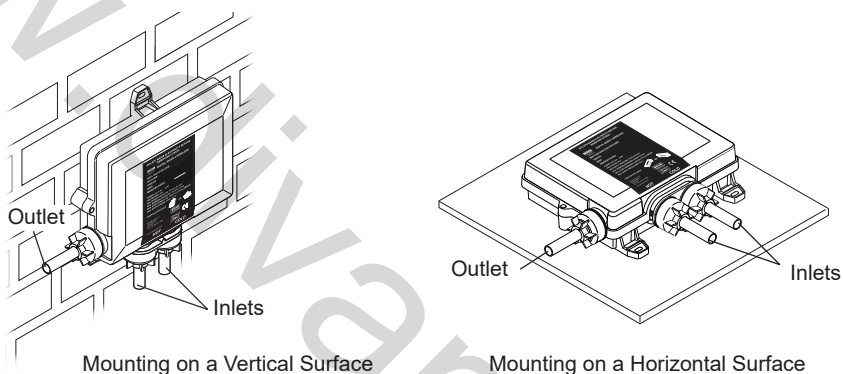

- ▶ The Digital Mixer Valve (which contains the thermostatic mixing valve) may **only** be orientated in the positions shown above when mounted on a vertical or horizontal surface. Failure to do so will compromise the ability of the unit to fail-safe and deliver constant blend.
- ▶ If the power supply cable is damaged, it **must** be replaced by the manufacturer or a service engineer.
- ▶ **Warning! Turn off the electrical and water supplies before proceeding with the installation of the appliance. The electricity must be turned off at the mains and the appropriate circuit fuse electrically isolated, if applicable.**

Digital Mixer Valve

Position and Signal Test

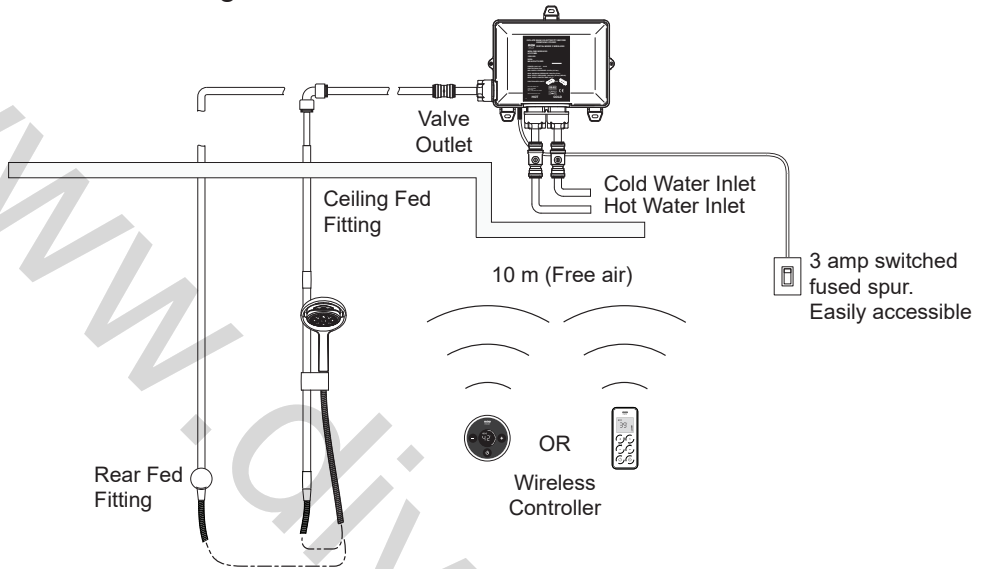

Important! When choosing a position for the Digital Mixer Valve in relation to the Wireless Controller and the Shower Fittings, consider the following points:

- ▶ The Wireless Controller can be sited up to 10 m (free air) from the Digital Mixer Valve. However, wall thicknesses and construction types may affect the remote signal strength and thereby reduce the range. The Controller range should be tested on site prior to installation to ensure shower's reliability. Refer to Section - **INSTALLATION "Important Information Regarding Radio Controlled Devices"**.
- ▶ The length of pipework running from the Digital Mixer Valve to the Shower Fitting will have an effect on the showering temperature and the response time when changing the temperature using the Wireless Controller. The shorter the length of pipework from the Digital Mixer Valve the better the shower will respond. It is recommended that this length does not exceed 5m from the valve outlet to shower fitting.
- ▶ The ambient temperature of Digital Mixer Valve site (loft space, airing cupboard etc...) can have an effect on showering temperature. Insulate all pipework as required, particularly from the Digital Mixer Valve to the Shower Fitting.
- ▶ The temperature indicated on the wireless controller display is measured inside the digital mixing valve and due to site conditions is not necessarily the temperature delivered at the shower outlet.

- ▶ Fit 3 x AA batteries (supplied) into the wireless controller.
- ▶ Depending on the type and version of your wireless controller, the software revision number (eg. r04) may be briefly displayed, the controller will then display its default time of 10:00.
- ▶ Place Wireless Controller in approximate final position (no more than 10 m (free air) from Digital Mixer Valve) and test wireless signal by pressing the “⏻” or “⏮” or “⏭”, and adjusting the temperature. If temperature display remains unchanged and “out of range” symbol is displayed, units are unable to communicate with each other.
- ▶ A sluggish response to button presses indicates poor radio communication without the out of range symbol being displayed.
- ▶ If test fails, reposition unit(s) and repeat test until satisfied shower will work reliably.
- ▶ **Caution! Risk of product damage. Do not run Pumped Valve (low pressure version) without a water supply for longer than 5 minutes during test.**
- ▶ Isolate electrical supply to Digital Mixer Valve.
- ▶ Mark the fixing holes in the required positions.

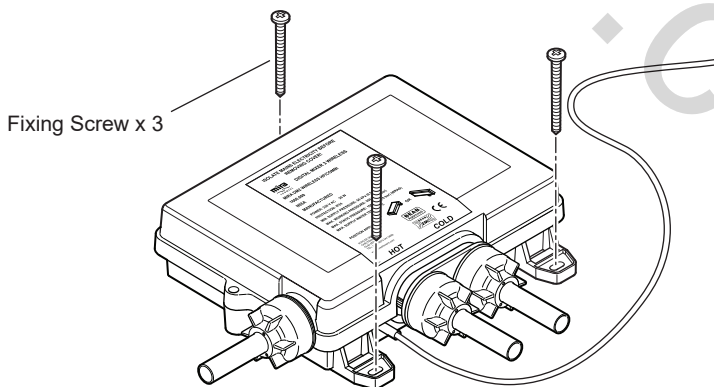
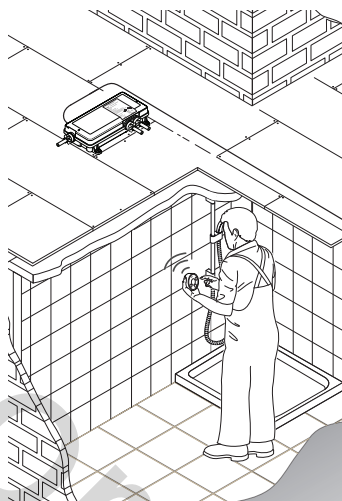

- ▶ Drill and plug the fixing holes.
- ▶ **Note:** Installers may wish to use alternative cavity fixings, when installing onto a dry lined, stud partition, shower cubicle or laminated panel wall structures. However, these methods of fixing are beyond the scope of this guide.
- ▶ Secure the Digital Mixer Valve in position with the fixing screws (supplied).
- ▶ **Caution! Risk of product damage. Make sure both hot and cold supply pipes are flushed thoroughly prior to connection to the Digital Mixer Valve. Any product malfunction caused by pipework debris is not covered under the guarantee.**
- ▶ Connect the hot and cold water supply pipes to the Digital Mixer Valve as indicated on the product lid.

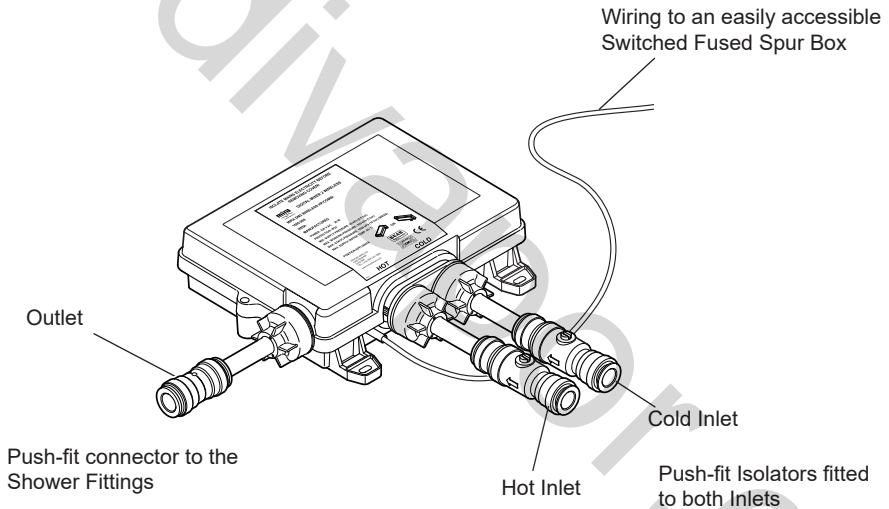

- ▶ Install the Shower Fittings and Wireless Controller (see further instructions).

Shower Fittings - Ceiling Fed

Suitable for solid, dry-lined, stud partition, shower cubicle or laminated panel walls.

The Slide Bar should be fixed to the wall at a convenient height for all the family. It should be positioned so that water sprays down the centre of the bath, or away from the opening of a shower cubicle. Water should spray away from the Wireless Controller when the Showerhead is held on the Slide Bar.

- ▶ Decide on suitable position for Slide Bar avoiding buried cables and pipes in both wall and ceiling. Make sure slide bar extension will fit through ceiling. Ceiling hole centre can be altered to avoid roof joists by using supplied spacers.

- ▶ Using template as guide, mark positions of the fixing holes for Wall Brackets (600 mm). Upper hole to be no more than 645 mm from ceiling.

Note: Use spirit level to make sure fixing holes are vertical.

- ▶ Fold long end of template and move up to ceiling. Using upper marked fixing hole as guide, mark centre for hole in ceiling.

- ▶ **Important! If supplied Slide Bar spacers are required, centre distance for hole will increase to 75 mm from wall.**

- ▶ Cut hole in ceiling 29 mm diameter.

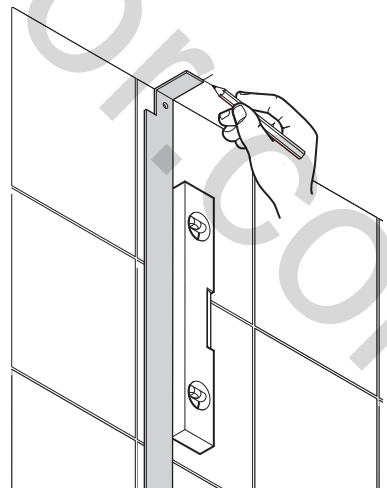
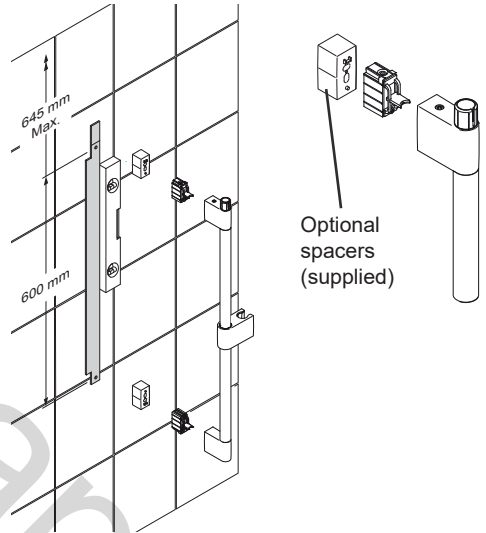

- ▶ Drill and plug Slide Bar Assembly fixing holes.

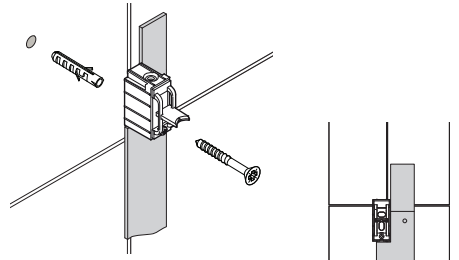

- ▶ Insert fixing screws through holes in Wall Brackets and fix to wall. Do not fully tighten. Use template to set correct distances between Wall Brackets. Fully tighten screws. Use longer fixing screws if using spacers supplied.

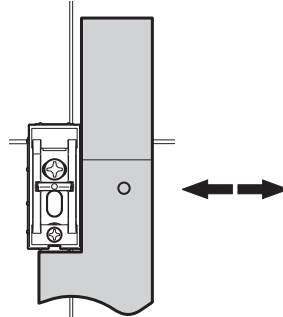

- ▶ **Note:** Slots in Wall Brackets allow for adjustment. Use one horizontal slot and one vertical slot. Make sure that holes for Slide Bar Securing Screws are positioned correctly, as shown.

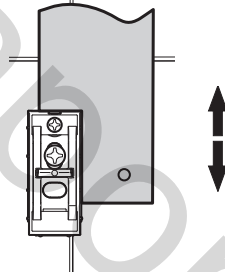

- ▶ Fit ceiling plate and extension tube.

- ▶ **Note:** Extension tube may need to be shortened, use a hacksaw to shorten tube. Make sure rough end is concealed in ceiling.

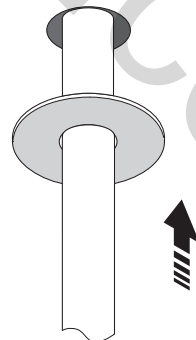

- ▶ Fit Slide Bar Assembly over Wall Brackets and secure with screws supplied. (Do not overtighten.)

- ▶ Connect ceiling extension tube.

- ▶ Feed plastic pipe up through the slide bar and extension into ceiling. Do not allow any debris to block the plastic pipe.

- ▶ **Note:** If plastic pipe requires shortening, make sure there is enough length to fit elbow (supplied) or alternative push-fit/compression fitting (not supplied).

- ▶ When shortening for use with any push-fit (e.g. John Guest) fitting, follow manufacturer's guidelines for finishing and cleaning the pipe.

- ▶ Push and twist plastic pipe end until it “**clicks**” and locks in place.

Connect plastic pipe in ceiling to outlet pipe from valve using elbow supplied. Push all parts together fully.

- ▶ Connect elbow to Digital Mixer Valve. Fit an isolating valve between to enable easy maintenance. (Pipe and isolating valve not supplied). Follow manufacturer's guidelines for fitting alternative push-fit connections and flexible pipework.

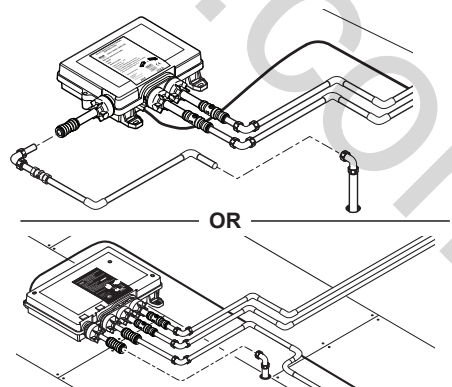
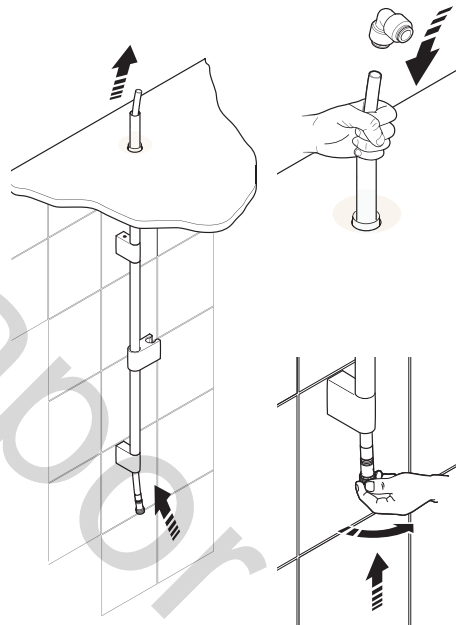
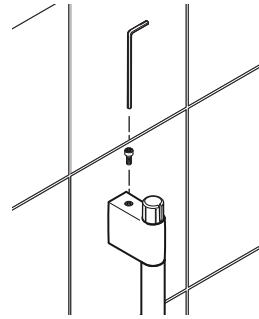

- ▶ Place first washer in end of hose, then attach to pipe end. Do not fit showerhead until after pipework has been fully flushed through. See section “**Commissioning**”.

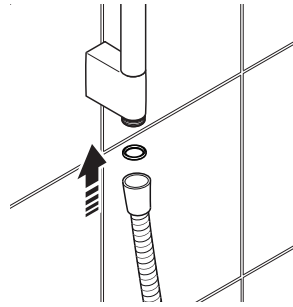

Ceiling Fed Deluge Head

The Deluge Head should be fixed to the ceiling at a convenient height for all the family. It should be positioned so that water sprays down over the centre of the bath, or away from the opening of a shower cubicle.

The fitting of the Deluge Head into the ceiling will be easier with the aid of a helper. When you are working within the bath or shower tray area use a towel or blanket to protect the surface from damage.

- ▶ Decide on a suitable position for the Deluge Head avoiding cables and pipes hidden between joists or rafters. **Note:** A timber noggin or plywood plinth securely fixed to the joist should be used to mount the Deluge Head.

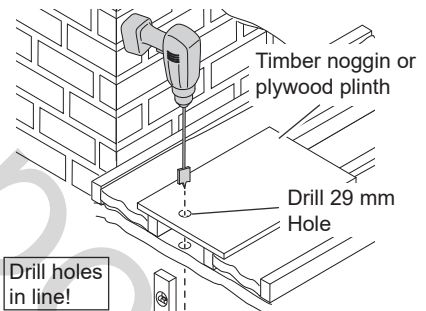

- ▶ Drill a 29 mm hole through the ceiling and the wooden support. Ensure the two holes drilled are directly in line or the ceiling pipework will be at an angle.

- ▶ Push the Brazed Pipe through the Ceiling Mount Plate then push the threaded end of the brazed pipe down through the holes made in the ceiling.

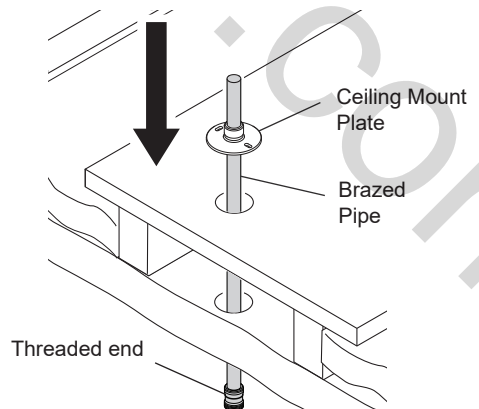

- ▶ Centralise the brazed pipe in the hole then screw the ceiling mount plate to the wooden support.

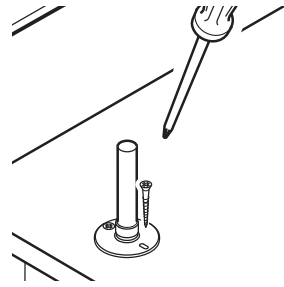

- ▶ Offer the deluge head to the brazed pipe and determine the showering height required. Push / pull the brazed pipe using a twisting motion to adjust the height. Check the height is correct and use a 15 mm pipe cutter to cut the pipe to the desired length. **Note:** Cut the brazed pipe at least 30 mm above the ceiling mount plate to allow room to fit the olive, nut and elbow.

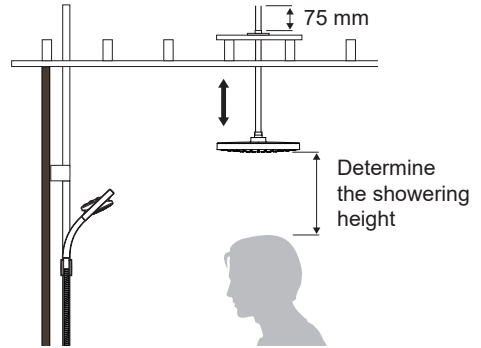

- ▶ Secure the brazed pipe to the ceiling mount plate with the olive and 1/2" BSP nut. **Note:** This is not a water tight connection, tighten sufficiently to clamp the pipe in place.

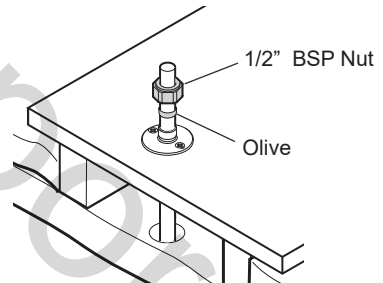

- ▶ Offer the Chrome Extension Tube to the brazed pipe and determine the length required to allow the tube to conceal the brazed pipe and protrude into the ceiling space a minimum of 15 mm. Use a pipe cutter to cut the tube to the desired length. Remove all burrs. **Note:** Take care not to crush the pipe when cutting.

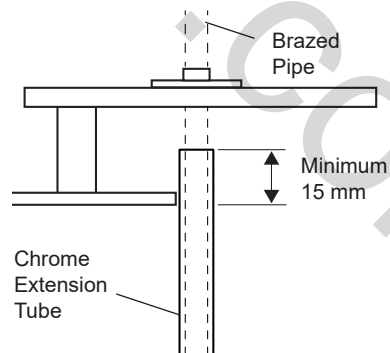

- ▶ Push the cut end of the chrome extension tube into the Concealing Plate then slide the extension tube over the threaded end of the brazed pipe and up through the hole until the concealing plate is secured in the hole and the concealing plate is flat against the ceiling.

Note: If the hole in the ceiling is oversized use silicone sealant on the underside of the concealing plate to retain it.

- ▶ Connect brazed pipe in ceiling to outlet pipe from digital mixing valve using elbow supplied. Push all parts together fully.

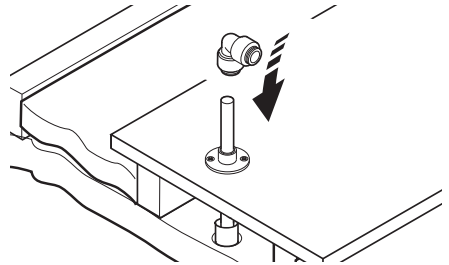
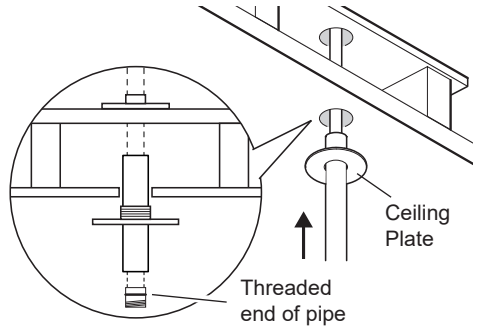

- ▶ Connect elbow to digital mixer valve. Fit an isolating valve between to enable easy maintenance. (Pipe and isolating valve not supplied). Follow manufacturers guidelines for fitting alternative push-fit connections and flexible pipework.

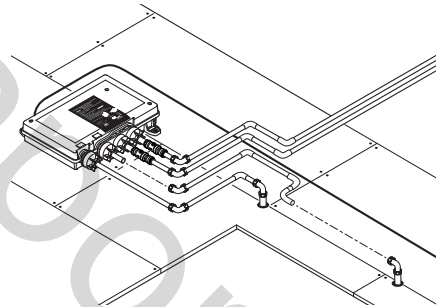

- ▶ Do not fit deluge head until after pipework has been fully flushed through. Refer to section “**Commissioning**” in Digital Mixer Valve Installation guide.

- ▶ Screw the deluge head onto the brazed pipe outlet by hand. **Note:** Use two suitably sized wrenches to fully tighten (approximately 1/4 turn).

- ▶ Slide the extension tube down to conceal the brazed pipe.

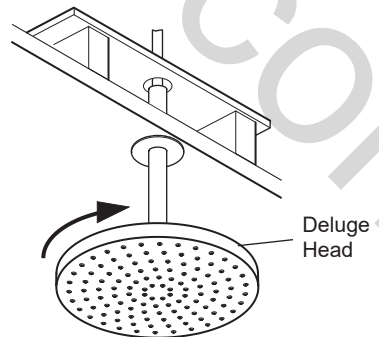

Shower Fittings - Rear Fed

Suitable for solid, dry-lined, stud partition, shower cubicle or laminated panel walls.

The Slide Bar should be fixed to the wall at a convenient height for all the family. It should be positioned so that water sprays down the centre of the bath, or away from the opening of a shower cubicle. Water should spray away from the Wireless Controller when the Showerhead is held on the Slide Bar.

- ▶ Decide on suitable position for Slide Bar avoiding buried cables and pipes in wall.
- ▶ Using template as guide, mark positions of the fixing holes for Wall Brackets (600 mm).

Note: Use spirit level to make sure fixing holes are vertical.

- ▶ Drill and plug fixing holes.

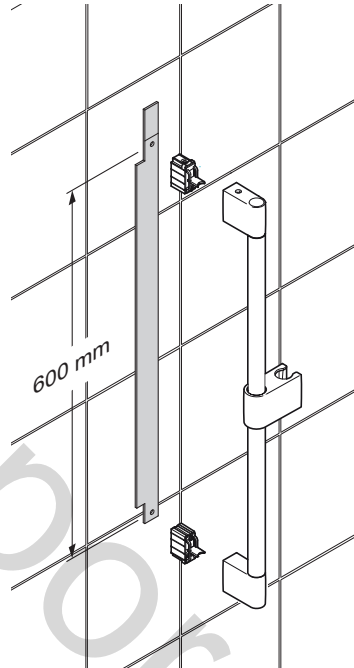

- ▶ Insert fixing screws through holes in Wall Brackets and fix to wall. Do not fully tighten at this stage. Use template to set correct distances between Wall Brackets. Fully tighten screws.

Note: Slots in Wall Brackets allow for adjustment. Use one horizontal slot and one vertical slot.

Make sure that holes for Slide Bar Securing Screws are positioned correctly, as shown.

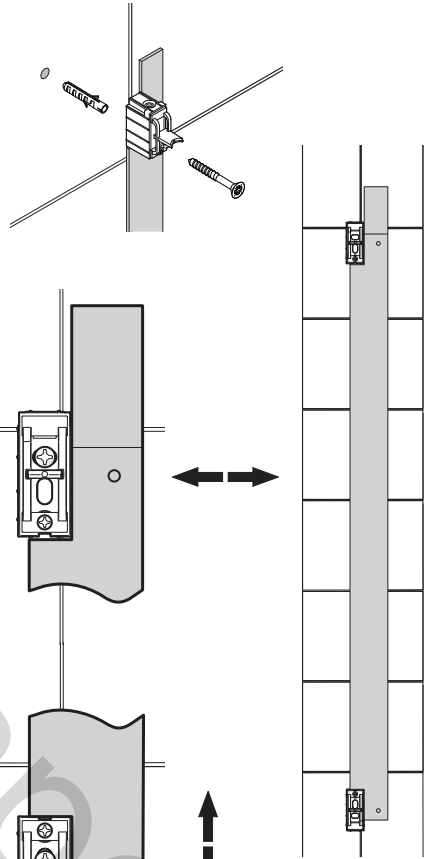

- ▶ Position Slide Bar over Wall Brackets and secure with screws. (Do not overtighten.)
- ▶ Fit Slide Bar End Caps into top and bottom of Slide Bar Assembly. Push and twist caps until they “click” and lock in place.

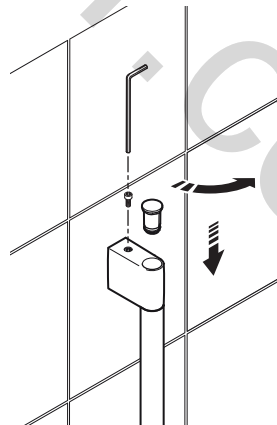

- ▶ Fit an isolating valve (not supplied) close to the Digital Mixer Valve for ease of maintenance.

- ▶ Make sure that the outlet pipe work protrudes approx. 60 mm through a Dia 20 mm hole square to the finish wall surface.

Note: To be trimmed after completion of finished wall surface when installing RAC.

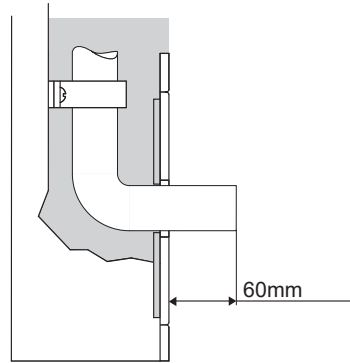

- ▶ Finish the surface of the wall as required.

- ▶ Trim the pipework back to the required depth from the finished wall surface. Remove all burrs and sharp edges.

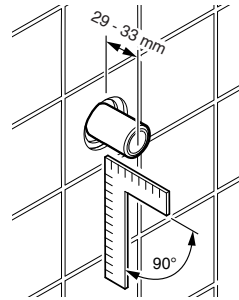

- ▶ Disassemble the right angle connector assembly and mark the locations of the screw fixings.

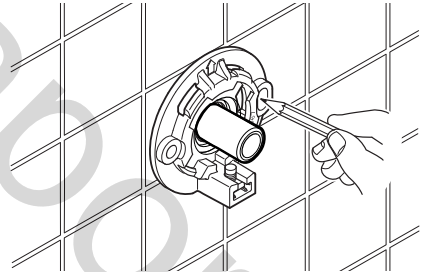

- ▶ Drill the fixing holes. (7 mm diameter for screws supplied.)

DO NOT drill through the backplate into the wall.

DO NOT drill into buried cables or pipes.

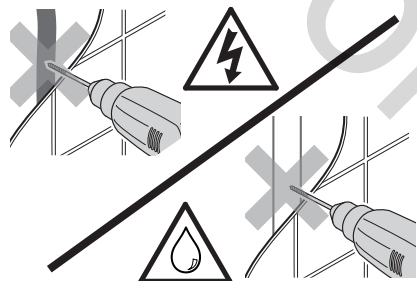
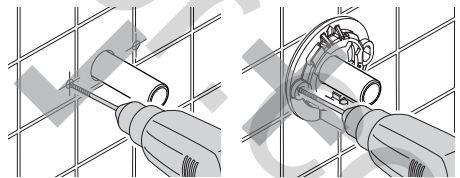

- ▶ Secure the backplate to the wall so the foam seal is fully compressed.

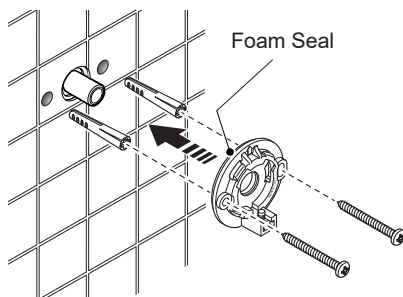

- ▶ Fit the pipe collar and lock. Re-check the pipe length.

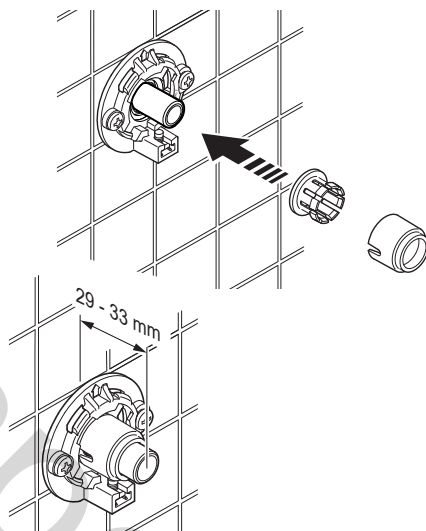

- ▶ Flush pipework to clear all debris.

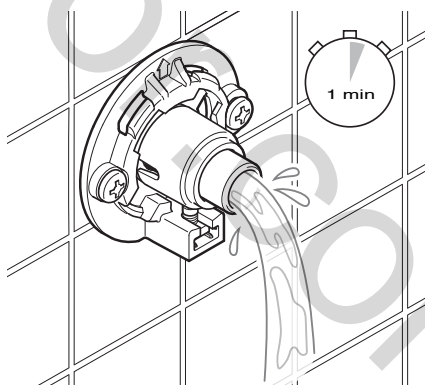

- ▶ Fit the o seal and elbow.

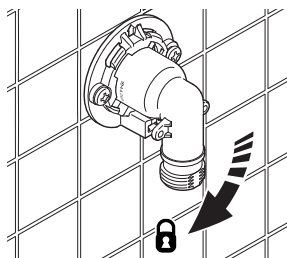
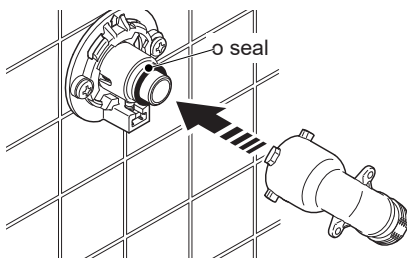

- ▶ Check for leaks.

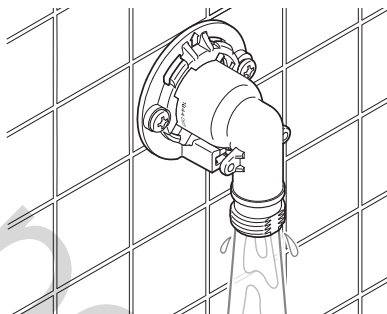

- ▶ Fit the cover. Carefully lift the cover to locate the screw. Unscrew fully to lock using the 2.5 mm hex key supplied.

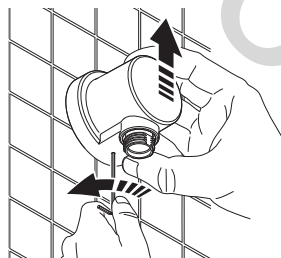
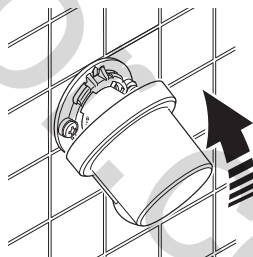

Rear Fed Shower Arm and Deluge Head (Dual Outlet Only)

The Shower Arm and Deluge Head should be fitted at a convenient height for all the family. It should be positioned so that water sprays down over the centre of the bath, or away from the opening of a shower cubicle.

- ▶ The outlet pipe **must** protrude 18 mm (± 2 mm) from the finished wall surface and a minimum 35 mm from the ceiling.
Note: Cut the pipe to the correct length and remove any burrs.

- ▶ Fit an isolating valve (not supplied) close to the Digital Mixer Valve for ease of maintenance.

- ▶ Mark the positions of the backplate fixing holes.
Caution! Be aware of hidden pipes or cables

- ▶ For solid walls drill the fixing holes for the backplate with a 6 mm drill and insert the wall plugs (supplied). For other types of wall structure alternative fixings may be required (not supplied).
Caution! Take care not to drill into hidden pipes or cables.

- ▶ Carefully fit the backplate over the outlet pipe and secure with the fixing screws (supplied).
Caution! Take care not to damage the 'O' Seal in the back of the backplate.

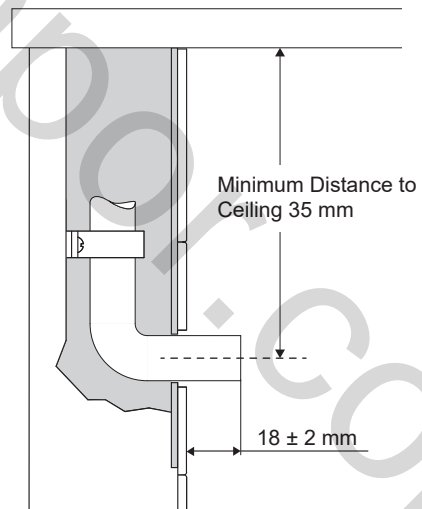
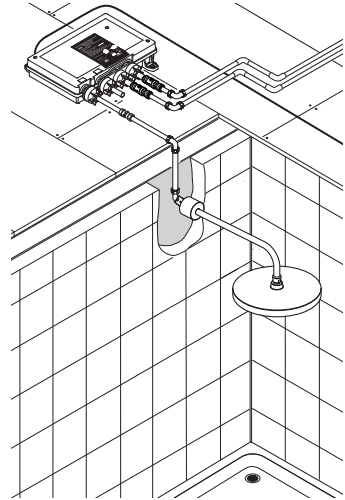

- ▶ Fit the olive and compression nipple over the outlet pipe and tighten the compression nipple.

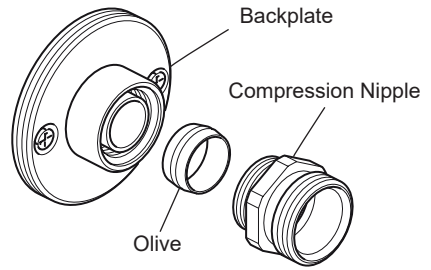

- ▶ Fit the concealing shroud onto the shower arm.
- ▶ Fit the compression nut and olive onto the shower arm.

- ▶ Fit the shower arm into the compression nipple and tighten the compression nut.

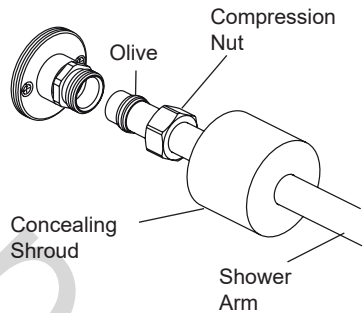

- ▶ Hand tighten the concealing shroud onto the backplate.

- ▶ Do not fit deluge head until after pipework has been fully flushed through. Refer to section “**Commissioning**” in the Dual Outlet Installation Guide.

- ▶ Screw the deluge head onto the shower arm by hand.
Note: Use a suitably sized wrench to fully tighten (approximately 1/4 turn).

Caution! The shower arm is not designed to take weight, therefore care needs to be taken when installing the deluge head.

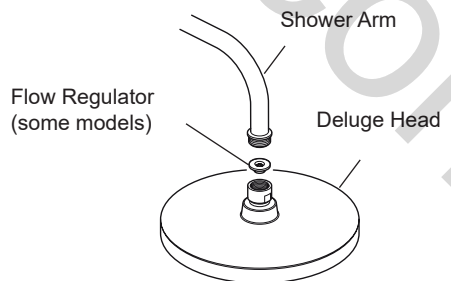

Wireless Controller

Suitable for solid, dry-lined, stud partition, shower cubicle or laminated panel walls. The Wireless Controller should be fixed to the wall at a convenient height for all the family. It should be positioned so that water does not spray over it when the Showerhead is held on the Slide Bar.

Important! Make sure wireless signal has been tested between Wireless Controller and Digital Mixer Valve before permanently fixing to wall. See section 'INSTALLATION - Digital Mixer Valve: Position and Signal Test'.

- ▶ Mark position for backplate holes. Mount backplate on flat surface (e.g. Centre of tile). Drill and plug holes.

Caution! Avoid drilling through buried cables or pipes.

- ▶ Make sure surface is clean and dry. Fix backplate to finished wall surface.

- ▶ Turn controller over and remove the battery cover by loosening the 4 screws with a pozi drive screwdriver. **Note:** The screws remain attached to the battery lid.

- ▶ Only fit new batteries of same make and type. Do not use rechargeable batteries. Replace all three batteries at the same time.

- ▶ Secure battery cover.

- ▶ Hook Controller on top of backplate and push firmly until Controller "clicks" back into place.

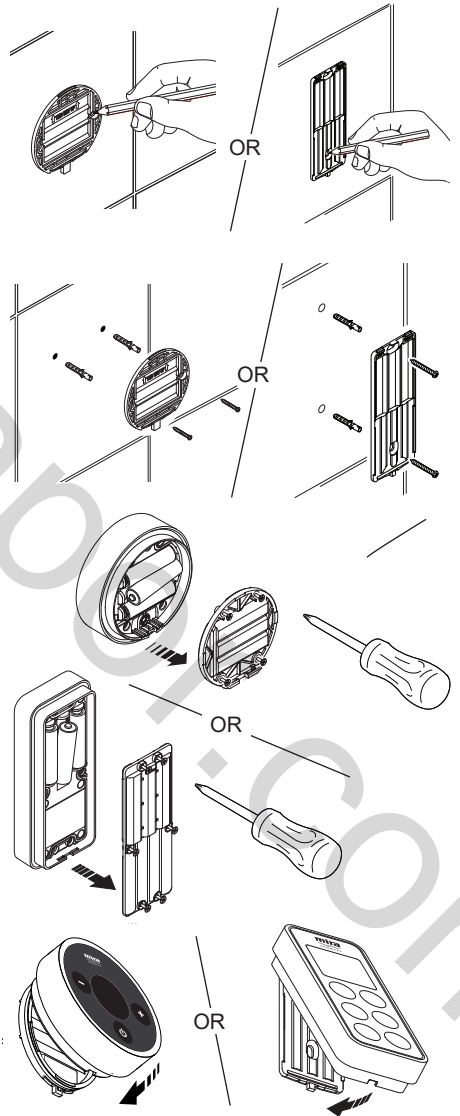

COMMISSIONING

- ▶ Turn on electrical supply to Digital Mixer Valve.

- ▶ Make sure the end of the hose is in either the bath, shower tray or other water catchment area.

Note: For dual outlet, The overhead mounting will flow water when switched on (“0” or “0”) depending on the outlet plumbing configuration.

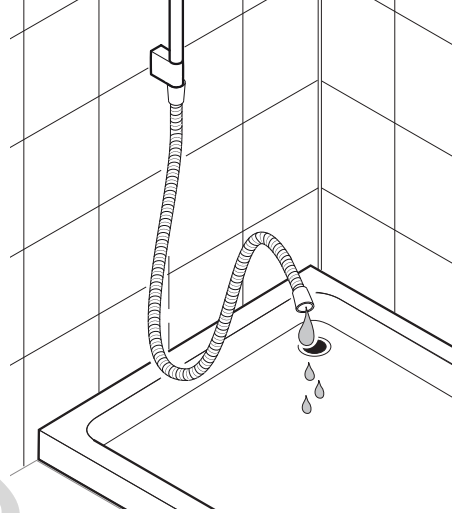

- ▶ Press “0” button and reduce temperature to full cold “CLd”. Increase to full flow. For Low Pressure (pumped) version, let shower run in order to prime the pump. For long pipe runs, allow 3 - 4 minutes for priming.

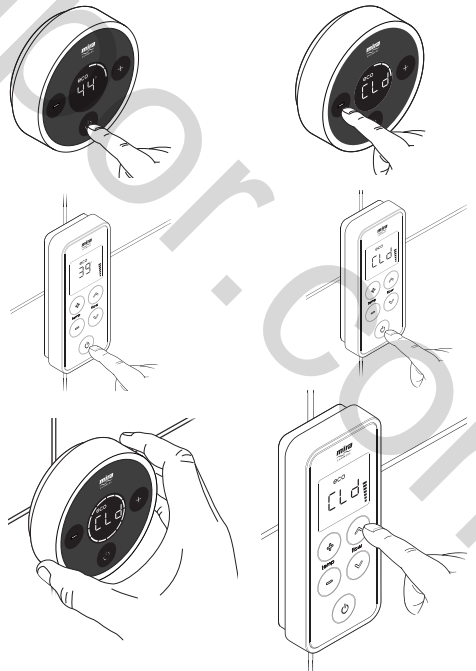

- ▶ Caution! Risk of product damage. Do not run Pumped Valve (low pressure version) without a water supply for longer than 5 minutes during priming.

- ▶ Run cold water through (approximately 2 minutes) and check entire installation for water leaks. Press “⏻” or “⏮” to turn shower off. Fit the second hose washer and showerhead.
- ▶ Press “⏻” or “⏮” to turn shower on. Test operation of shower by increasing/decreasing both temperature and flow controls. (See User Guide for full details.)
- ▶ Test operation of showerhead spray modes. (See Showerhead User Guide for full details.)
- ▶ For dual outlet, Repeat process for outlet 2 by pressing “⏻” button.
- ▶ Refer to User Guide for further instructions on how to use the shower.

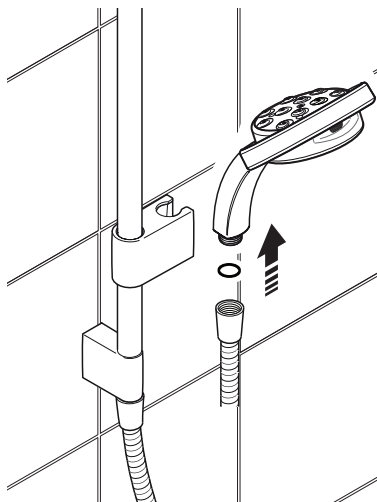

The Wireless Controller factory default settings are as follows:

Maximum Showering Temperature	= 45°C
Eco Mode	= Off
Warm-Up Mode	= Off
Clock	= 10:00 (when batteries connected)
Clock Display	= On
Shower Duration (For Dual Outlet)	= Off
Bath Fill Mode (For Dual Outlet)	= Off

Note: If the display reads 4:00 when the batteries are connected the wireless controller will require registering, refer to the initial registration process in section “Digital Mixer Valve: Position and Signal Test”.

Run the shower and adjust the maximum shower temperature to suit user requirement.

Eco, warm-up and clock display can also be altered to suit, refer to wireless controller guide.

CONNECTING A SECOND WIRELESS CONTROLLER

The following procedure details how to assign the Wireless Controller to the Digital Mixer Valve and test the remote signal strength.

Note: Other radio signals from sources such as mobile phones, radio controlled boiler thermostats, wireless broadband etc. can dramatically reduce the ability of the digital mixer valve to register.

It is recommended that such items are switched off during this process.

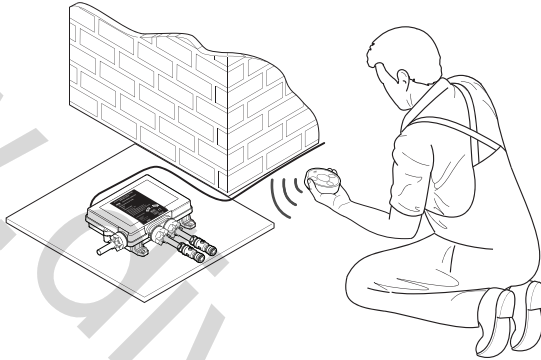

- ▶ Isolate electrical supply to the digital mixer valve.
- ▶ Bring the wireless controller to within approximately 1 m of the digital mixer valve. Fit the three AA batteries supplied into the wireless controller.
- ▶ Ensure the wireless controller LCD lights up then switch on power to the digital mixer valve.
- ▶ Depending on the type and version of your wireless controller, the software revision number (eg. r04) may be briefly displayed, the controller will then display its default time of 4:00 (unregistered).

The digital mixer valve will now begin to make a noise as it resets itself and registers with the wireless controller.

- ▶ **Registration in progress symbol or Droplet symbol** is displayed for approximately 30 seconds. Do not remove the batteries or switch off the digital mixer valve. **Registration in progress symbol or Droplet symbol** goes out indicating the digital mixer valve and wireless controller have been assigned to each other.
- ▶ Place wireless controller in approximate final position (no more than 10 m (free air) from digital mixer valve) and test wireless signal by pressing “0” or “1” or “2”, and adjusting the temperature. If temperature display remains unchanged and “**out of range**” symbol is displayed, units are unable to communicate with each other.
- ▶ If test fails, reposition the controller closer to the digital mixer valve and repeat test until satisfied the shower will work reliably at all times.



Registration in Progress Symbol or Droplet Symbol



Out of Range Symbol

RE-REGISTERING

The wireless controller has previously been registered to the digital mixer at the factory, if communication problems are encountered, a re-registering of the wireless controller may be required.

A re-registering of the wireless controller must also be performed should the control PCB in the Digital Mixer Valve be replaced.

To re-register the wireless controller to the Digital Mixer Valve carry out the following sequence.

- ▶ Isolate power to the Digital Mixer Valve.

- ▶ Press “+” and “⏻” or “⏻” buttons simultaneously until “End” is displayed on the screen.

- ▶ Restore power to the digital mixer valve.

- ▶ Briefly press the “+” and “⏻” or “⏻” buttons, “SET” will be displayed on the screen. **Note:** if display reads “Err” press “⏻” and repeat the process.

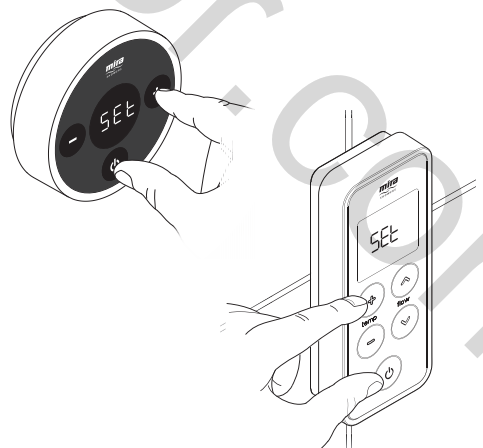
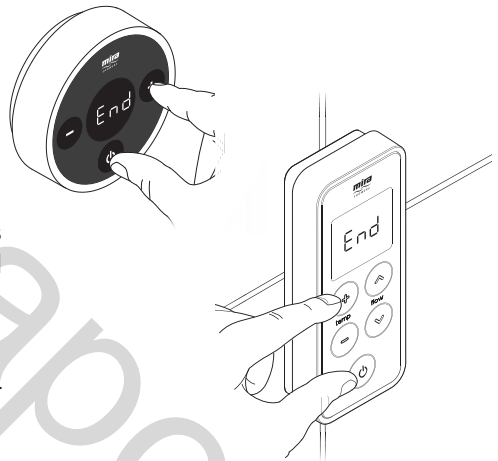

FAULT DIAGNOSIS

Read the section “**Important Safety Information**” first.

As with most electronic equipment resetting the mixing valve by powering it down waiting a few seconds then powering it up again can often cure any issues.

The Digital Mixer Valve is one part of an entire plumbing system. The fitting of a pump places additional requirements and some systems may require plumbing modifications to allow them to cope with higher flow rates.

Providing the Digital Mixer Valve has been correctly installed and is operated in accordance with the instructions contained in this guide, difficulties should not arise.

If any maintenance is required then it **must** be carried out by a competent tradesperson. Before replacing any parts make sure that the underlying cause of the malfunction has been resolved.



Warning! There are no user serviceable components beneath the cover of the appliance. Only a competent tradesperson should remove the cover.

Loss of/or poor radio communication (out of range symbol  maybe illuminated on wireless controller

Symptoms	Probable Cause	Possible Remedy
<p>Various faults or problems can be attributed to Loss of / or poor radio communications</p> 	<p>The wireless controller batteries are flat or incorrectly fitted.</p> <p>Aerial loose inside digital mixer box.</p> <p>Digital mixer sited too far from the wireless controller.</p> <p>Radio signal being blocked by building structure or other fixtures and fittings. Steel tanks, hot water cylinders, thick brick walls etc.</p> <p>External radio interference from other radio sources.</p> <p>Wireless controller lost registration.</p> <p>Digital Mixer valve box or Wireless Controller failure.</p>	<p>Refer to “Replacing the Batteries” in the Wireless Controller User Guide.</p> <p>Correctly fit the aerial inside the digital mixer box. (Isolate power before removing the Digital Mixing Valve lid).</p> <p>Reposition the digital mixer closer to the wireless controller or vice versa, refer to “Position and Signal Test”.</p> <p>Physical environment requires altering, refer to “Important Information Regarding Radio Controlled Devices”.</p> <p>Ensure all other radio transmitting devices, including mobile phones, are switched off, refer to “Position and Signal Test”.</p> <p>Re-register the wireless controller, refer to “Re-Registering”.</p> <p>Contact Kohler Mira Ltd.</p>

Symptoms	Probable Cause	Possible Remedy
General Fault Diagnostics		
No Display	<p>The wireless controller batteries are flat or incorrectly fitted.</p> <p>Wireless controller failure.</p>	<p>Refer to “Replacing the Batteries” in the Wireless Controller User Guide.</p> <p>Contact Kohler Mira Ltd.</p>
No water flow / will not turn on (wireless controller display is on)	<p>HP/Combi valve fitted to a Pumped Gravity water system.</p> <p>No power to the digital mixer.</p> <p>Inlet water supply isolators not fully turned on.</p> <p>Inlet water supply failure.</p> <p>Inlet filters or check valves blocked.</p> <p>Outlet hose or handset blocked.</p> <p>Digital Mixing valve air locking.</p> <p>Loss of / or poor radio communications (out of range symbol maybe illuminated on wireless controller).</p>  <p>Digital Mixer valve box or Wireless Controller failure.</p>	<p>HP/Combi valves are not suitable for Pumped Gravity water system, refer to “Typical Suitable Installation”.</p> <p>Check electrical connection and power supply.</p> <p>Check and remedy.</p> <p>Check and remedy.</p> <p>Check and remedy, refer to “Maintenance”.</p> <p>Check and remedy.</p> <p>Check for correct installation practices, repeat commissioning procedure and rearrange pipework to avoid airlock forming, refer to “Typical Suitable Installations”.</p> <p>Refer to “Loss of / or poor radio communications” section above.</p> <p>Contact Kohler Mira Ltd</p>

Symptoms	Probable Cause	Possible Remedy
Low flow	Flow adjustment on wireless controller set too low.	Increase flow using user wireless controller bezel (Platinum models) or flow buttons (non-Platinum models), refer to "Using The Shower" in the Wireless Controller User Guide.
	Inlet water supply isolators not fully turned on.	Check and remedy.
	Inlet filters or check valves blocked.	Check and remedy, refer to "Maintenance" .
	Outlet hose or handset blocked.	Check and remedy.
	Inlet Water pressures too low.	Check maintained water pressure is within recommended range, refer to "Specifications".
	Flow calibration (HP/Combi version only) not suitable for water system conditions.	Perform flow calibration procedure, refer to "Changing Function Settings" in the Wireless Controller User Guide.
	Digital Mixer valve air locking.	Check for correct installation practices, repeat commissioning procedure and rearrange pipework to avoid airlock forming, refer to "Typical Suitable Installations" .
	Digital Mixer valve box installed above cold water storage cistern (Pumped valve only).	No product fault. Appliance not suitable for negative head installation, refer to "Installation" .
Digital Mixer valve box failure.	Contact Kohler Mira Ltd.	

Symptoms	Probable Cause	Possible Remedy
<p>Keeps cutting out</p>	<p>“Eco” setting enabled. Eco reduces flow time to 5 minutes.</p> <p>“Warm-up” setting is enabled. Warm-up stops the flow of water once the shower has reached the desired showering temperature.</p> <p>“Shower run time” setting is enabled. Shower run time reduces the shower run time to a user defined time.</p> <p>Loss of / or poor radio communications (out of range symbol maybe illuminated on wireless controller).</p>  <p>Digital Mixing valve air locking.</p> <p>Digital Mixer valve box or Wireless Controller failure.</p>	<p>No product fault, refer to “using the shower” in the Wireless Controller User Guide book and set as required</p> <p>No product fault, refer to “using the shower” in the Wireless Controller User Guide book and set as required.</p> <p>No product fault, refer to “using the shower” in the Wireless Controller User Guide book and set as required.</p> <p>Refer to “Loss of / or poor radio communications” section above.</p> <p>Check for correct installation practices, repeat commissioning procedure and rearrange pipework to avoid airlock forming, refer to “Typical Suitable Installations”.</p> <p>Contact Kohler Mira Ltd.</p>
<p>Temperature and flow control is not very responsive</p>	<p>Loss of / or poor radio communications (out of range symbol maybe illuminated on wireless controller).</p>  <p>Digital Mixer valve box or Wireless Controller failure.</p>	<p>Refer to “Loss of / or poor radio communications” section above.</p> <p>Contact Kohler Mira Ltd.</p>

Symptoms	Probable Cause	Possible Remedy
<p>Shower temperature too cool</p>	<p>Temperature adjustment on wireless controller set too low.</p> <p>Unable to increase showering temperature because maximum shower temperature set too low for installation.</p> <p>Inlet filters or check valves blocked.</p> <p>Outlet hose or handset blocked.</p> <p>Reversed inlet supplies.</p> <p>Hot inlet water supply temperature is too cool.</p> <p>Insufficient quantity of stored hot water.</p> <p>Inlet water supply pressures are unstable or imbalanced.</p> <p>Combination boiler cutting in and out (HP/Combi valve only).</p> <p>Outlet pipe run is too long.</p> <p>Digital Mixer valve box or Wireless Controller failure</p>	<p>Increase the temperature by pressing the “+” button on the wireless controller, refer to “Using The Shower” in the Wireless Controller User Guide.</p> <p>Increase “F1 - Maximum Water Temperature”, refer to “Changing Functions/ Settings” in the Wireless Controller User Guide.</p> <p>Check and remedy, refer to “Maintenance”.</p> <p>Check and remedy.</p> <p>Check and remedy.</p> <p>Increase hot inlet water temperature to between 55°C and 65°C, refer to “Specifications”.</p> <p>Hot water supply running out, increase storage capacity to minimum 120 litres, refer to “Specifications”.</p> <p>Ensure the water supply pressures are stable and nominally equal, refer to “Specifications”.</p> <p>Contact Kohler Mira Ltd.</p> <p>Ensure outlet pipe work is thermally lagged.</p> <p>Contact Kohler Mira Ltd.</p>

Symptoms	Probable Cause	Possible Remedy
<p>Shower temperature too hot or fluctuates</p>	<p>Temperature adjustment on wireless controller set too high.</p> <p>Hot inlet water supply temperature is too hot.</p> <p>Inlet filters or check valves blocked.</p> <p>Combination boiler cutting in and out (HP/Combi valve only) causing blend temperature fluctuations.</p> <p>Inlet water supply pressures are unstable or imbalanced.</p> <p>Shower temperature affected by the use of adjacent hot/cold tap. Insufficiently sized pipework to feed both Digital Mixing Valve and taps at the same time.</p> <p>The 'Warm-up' feature is being used with a combi boiler (HP/Combi valve only) refer to 'Use of Warm-up'.</p> <p>Digital Mixer valve box or Wireless Controller failure.</p>	<p>Increase the temperature by pressing the “-” button on the wireless controller, refer to “Using The Shower” in the Wireless Controller User Guide.</p> <p>Reduce hot inlet water temperature to between 55°C and 65°C, refer to “Specifications”.</p> <p>Check and remedy, refer to “Maintenance”.</p> <p>Contact Kohler Mira Ltd.</p> <p>Ensure the water supply pressures are stable and nominally equal, refer to “Specifications”.</p> <p>Increase pipe sizes or separately feed shower, refer to “Installation” for correct plumbing method.</p> <p>Disable the 'warm-up' feature, refer to 'Changing Functions' in the Wireless Controller User Guide.</p> <p>Contact Kohler Mira Ltd.</p>

Symptoms	Probable Cause	Possible Remedy
<p>User Interface displaying Error 3 or Error 7 - Showering temperature has got too hot and the Digital Mixer has safely shutdown</p>	<p>Valve has thermally shutdown</p> <p>Hot inlet water supply temperature is too high.</p> <p>Combination boiler cutting in and out (HP/Combi valve only) causing blend temperature fluctuations.</p> <p>Cold inlet water supply pressure too low or fluctuating.</p> <p>Cold inlet water supply failure.</p> <p>Inlet filters or check valves blocked.</p> <p>Digital Mixing valve air locking.</p> <p>Reversed inlet supplies.</p> <p>Digital Mixer valve box failure.</p>	<p>Isolate power to the digital mixer, wait 30 seconds and restore power.</p> <p>Reduce hot inlet water temperature to between 55°C and 65°C, refer to “Specifications”.</p> <p>Contact Kohler Mira Ltd.</p> <p>Ensure the water supply pressures are stable and nominally equal, refer to “Specifications”.</p> <p>Check and remedy.</p> <p>Check and remedy, refer to “Maintenance”.</p> <p>Check for correct installation practices, repeat commissioning procedure and rearrange pipework to avoid airlock forming, refer to “Typical Suitable Installations”.</p> <p>Check and remedy.</p> <p>Contact Kohler Mira Ltd.</p>
<p>Internal Leaking</p>	<p>Pumped Gravity LP valve fitted to a HP/Combi water system.</p> <p>Digital Mixer valve box failure.</p>	<p>Pumped Gravity LP valves are not suitable for connection to HP/Combi water systems, refer to “typical suitable installation”.</p> <p>Contact Kohler Mira Ltd.</p>

Symptoms	Probable Cause	Possible Remedy
<p>No shut off / Continuous flow / Shower Fitting Drain Down</p>	<p>Natural drain down of shower fittings.</p> <p>Loss of / or poor radio communications (out of range symbol maybe illuminated on wireless controller).</p>  <p>Digital Mixer valve box failure.</p>	<p>No Product Fault. It is natural for all shower outlets to continue to expel water for a short period of time after use. It is not uncommon for larger deluge shower heads, particularly those connected to long outlet pipe runs and therefore holding large volumes of water, to drain down water several hours after use due to the changes in the ambient temperature. We would therefore recommend that all water outlets are kept enclosed within the water catchment area.</p> <p>Refer to “Loss of / or poor radio communications” section above.</p> <p>Contact Kohler Mira Ltd.</p>
<p>Noise</p>	<p>Digital Mixing valve air locking.</p> <p>Water Hammer.</p> <p>Amplified acoustic noise from the pump due to structure of wall or flooring mounting.</p> <p>Digital Mixer valve box failure.</p>	<p>Check for correct installation practices, repeat commissioning procedure and rearrange pipework to avoid airlock forming, refer to “Typical Suitable Installations”.</p> <p>Ensure all pipework is securely fixed, refer to “Installation”.</p> <p>The type of wall or flooring the appliance is fixed to will affect the perceived noise level; solid walls will provide a quieter operation.</p> <p>Contact Kohler Mira Ltd.</p>

MAINTENANCE

General

Read the section “Important Safety Information” first.

Before replacing any parts ensure that the underlying cause of the malfunction has been resolved.

If the shower is dismantled during installation or servicing then upon completion the product must be inspected to ensure there are no leaks.

Warning! There are no user serviceable components beneath the cover of the appliance. Only a competent tradesperson should remove the cover.

Cleaning

Many household cleaners contain abrasives and chemical substances, and should not be used for cleaning plated or plastic fittings. These finishes should be cleaned with a mild washing up detergent or soap solution, and then wiped dry using a soft cloth.

Checkvalve Cartridges and Filters - Removal and Installation

Hot water entering the cold supply, or vice versa, indicates that immediate attention is necessary. This is carried out by removing and cleaning, or renewing as necessary, the checkvalve cartridges.

- ▶ Isolate the electrical and water supplies to the Digital Mixer Valve, and open an outlet fitting to release pressure and to assist the draining of residual water.
- ▶ Unscrew plastic nuts and either withdraw pipework or remove Digital Mixer to gain access to the checkvalve cartridges and filters.
- ▶ Use flat blade screwdriver to carefully lever cartridges out.
- ▶ Remove filters and clean or renew.
- ▶ Refit seals and plastic nuts. Plastic nuts require hand tightening only.
- ▶ Restore water supply and electrical supply. Test shower and check for leaks.

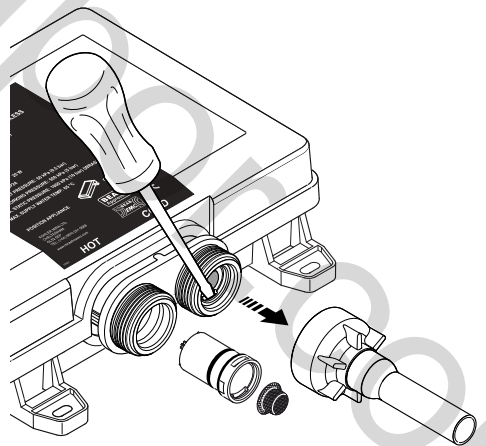

SPARE PARTS

Mira Platinum & Vision Digital Mixer Single Outlet - High Pressure/Combi Valve

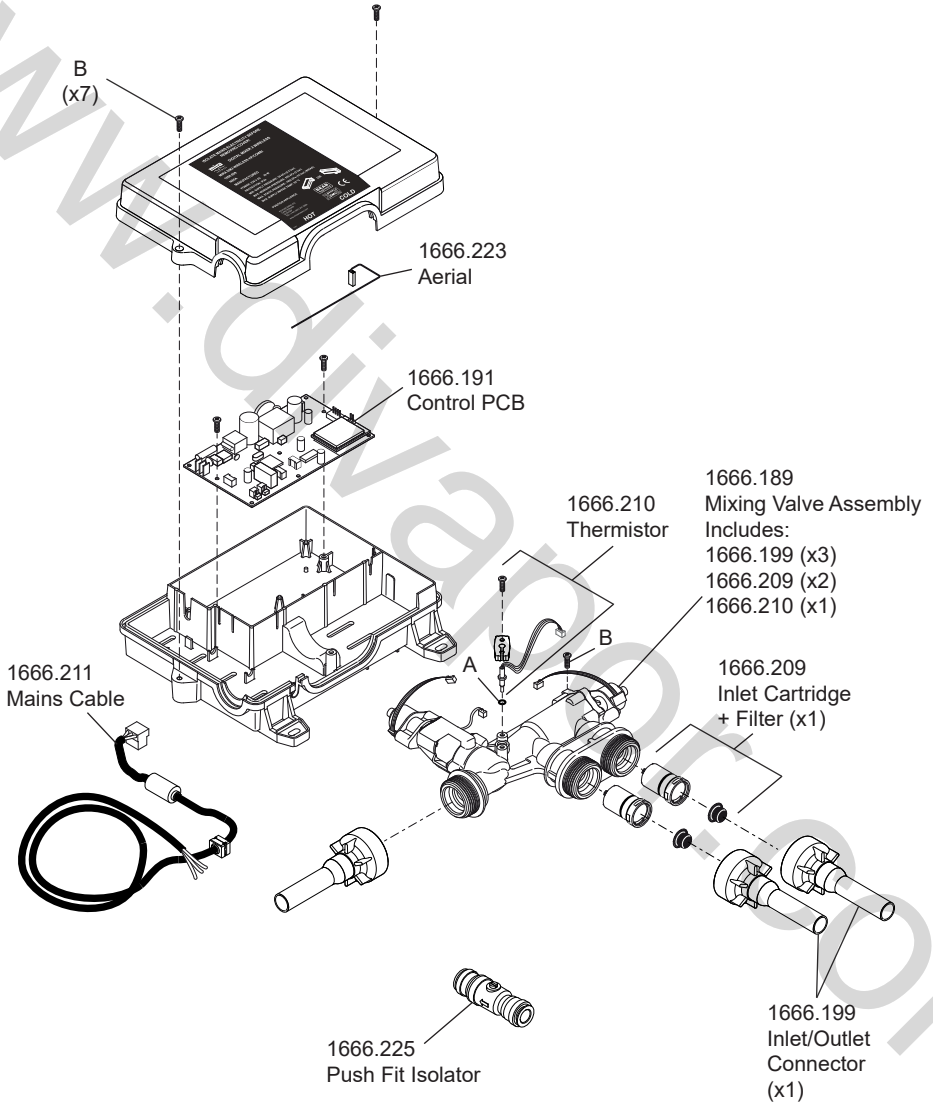

1666.212 Seal Pack - Components Identified 'A'
1666.213 Screw Pack - Components Identified 'B'

Mira Platinum & Vision Digital Mixer Single Outlet - Pumped Valve

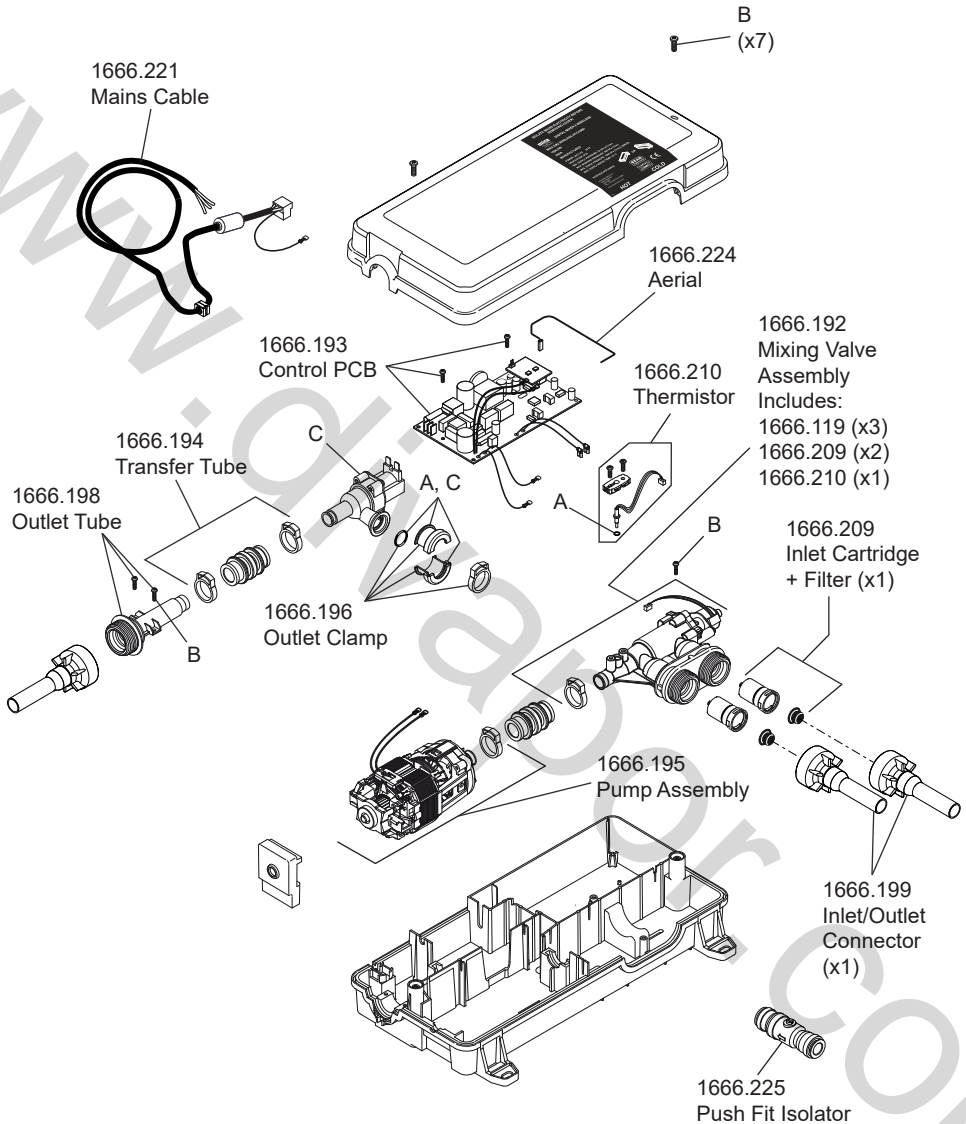

1666.212 Seal Pack - Components Identified 'A'
 1666.213 Screw Pack - Components Identified 'B'
 1666.197 Solenoid - Components Identified 'C'

Mira Platinum & Vision Digital Mixer Dual Outlet - High Pressure/Combi Valve

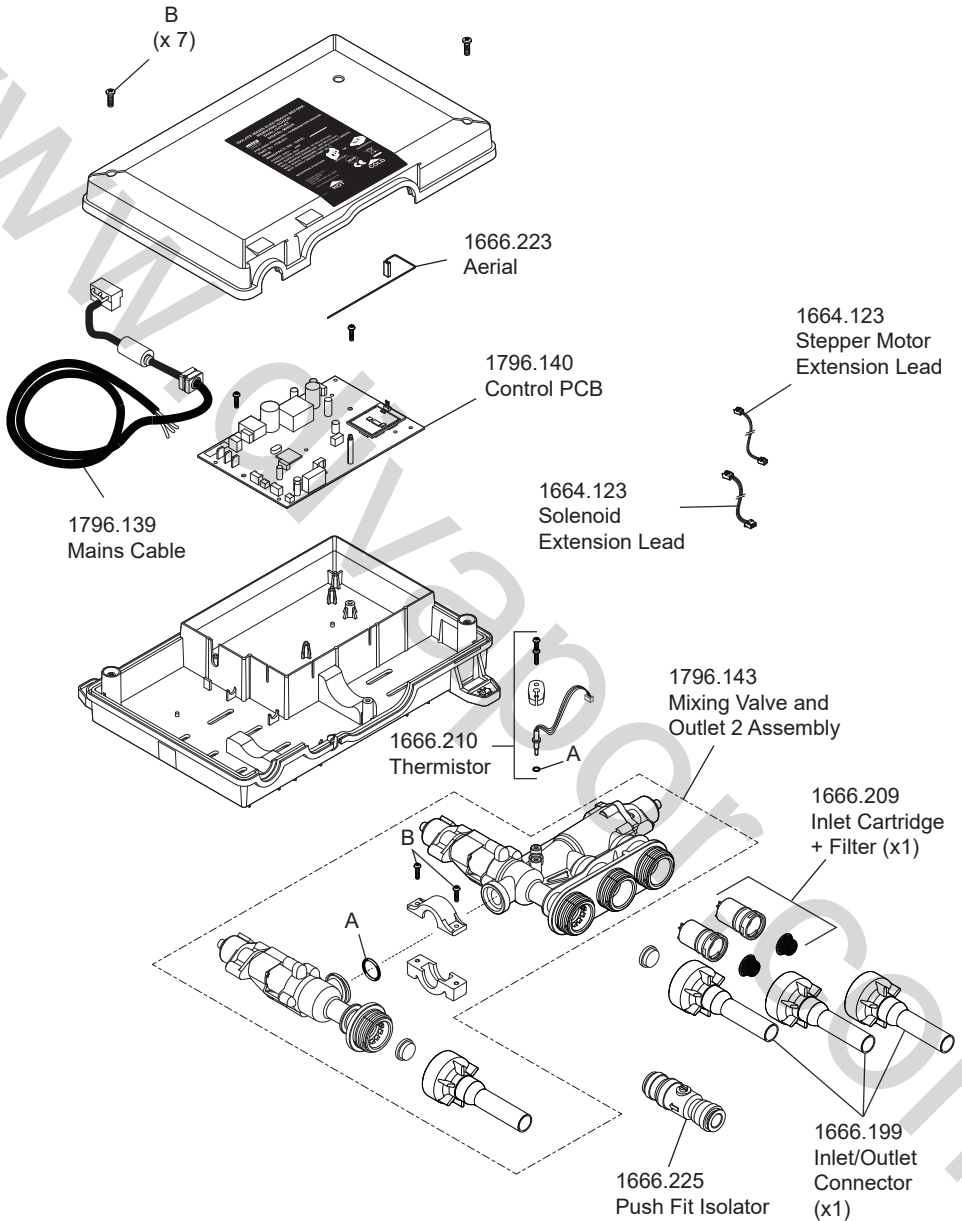

1666.212 Seal Pack - Components Identified 'A'
1666.213 Screw Pack - Components Identified 'B'

Mira Platinum & Vision Digital Mixer Dual Outlet - Pumped Valve

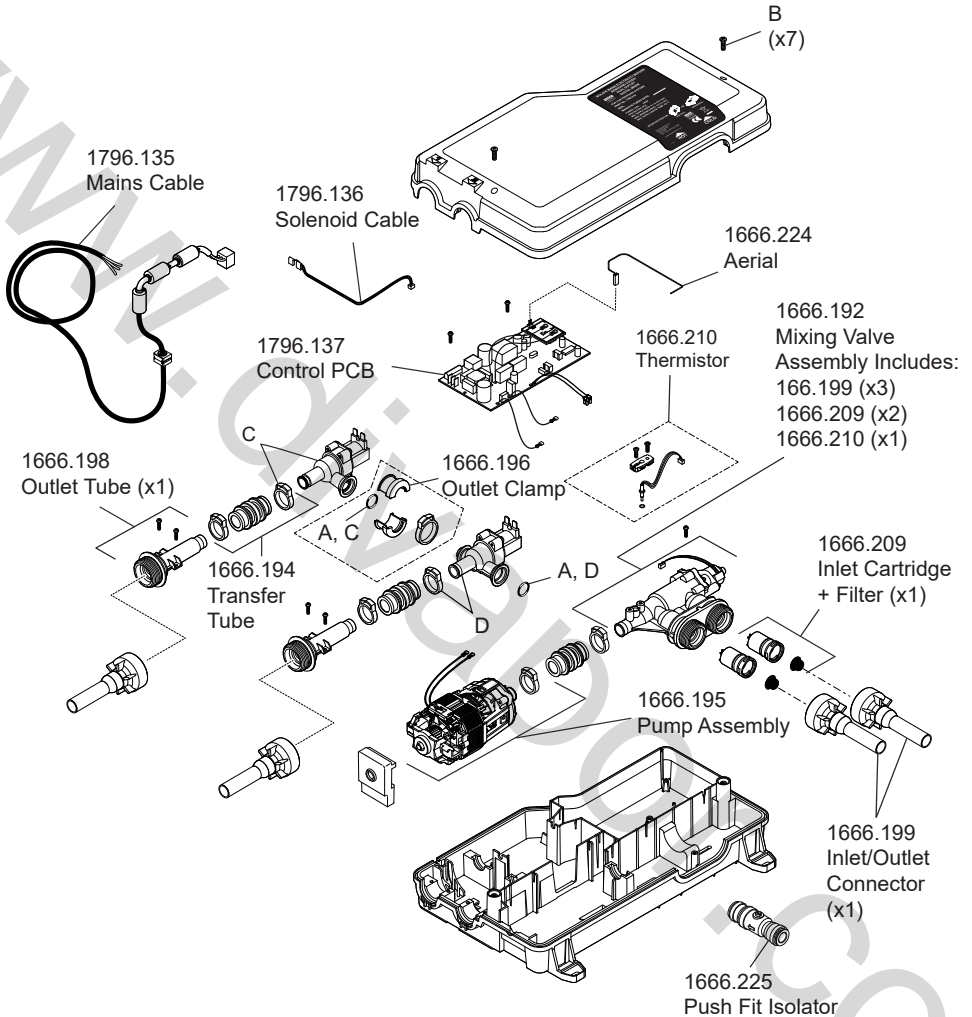

- 1666.212 Seal Pack - Components Identified 'A'
- 1666.213 Screw Pack - Components Identified 'B'
- 1666.197 Solenoid - Components Identified 'C'
- 1796.138 2nd Outlet Solenoid - Components Identified 'D'

Mira Platinum Single Outlet Digital Mixer - User Interface

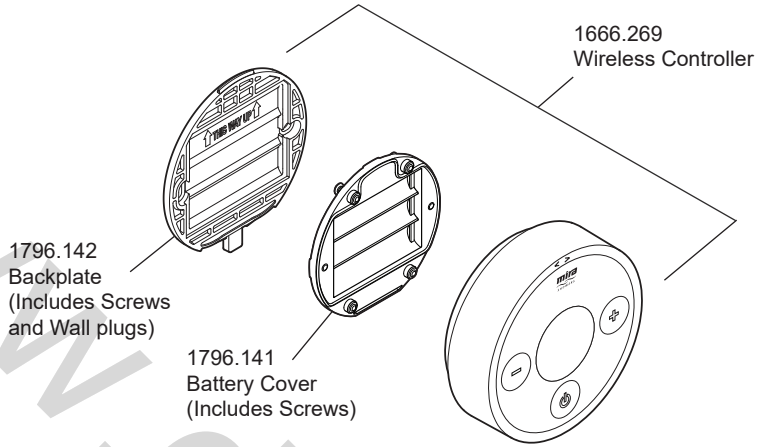

Mira Platinum Dual Outlet Digital Mixer - User Interface

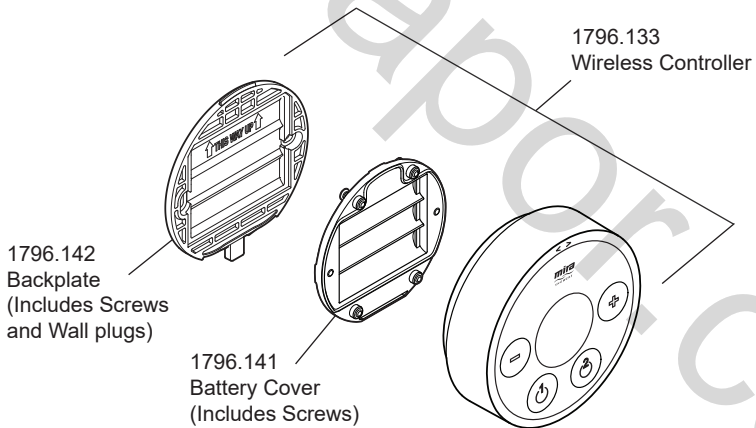

Mira Vision Single Outlet Digital Mixer - User Interface

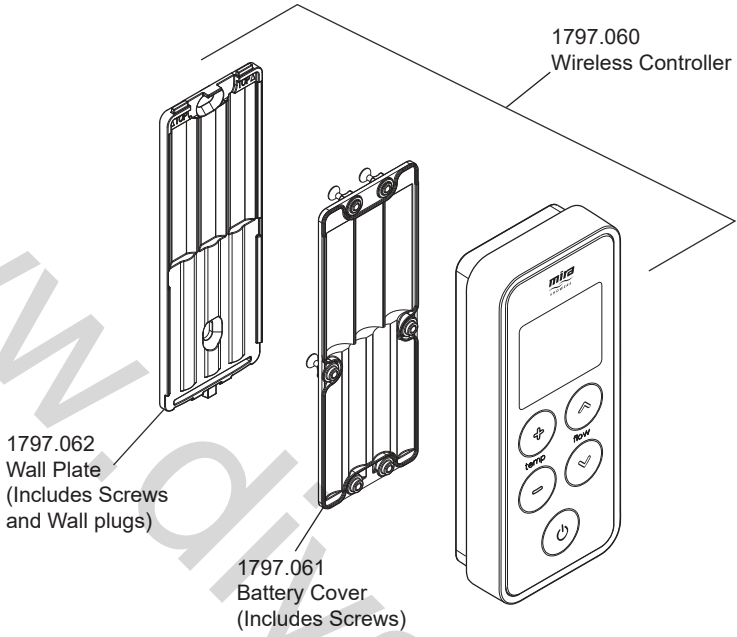

Mira Vision Dual Outlet Digital Mixer - User Interface

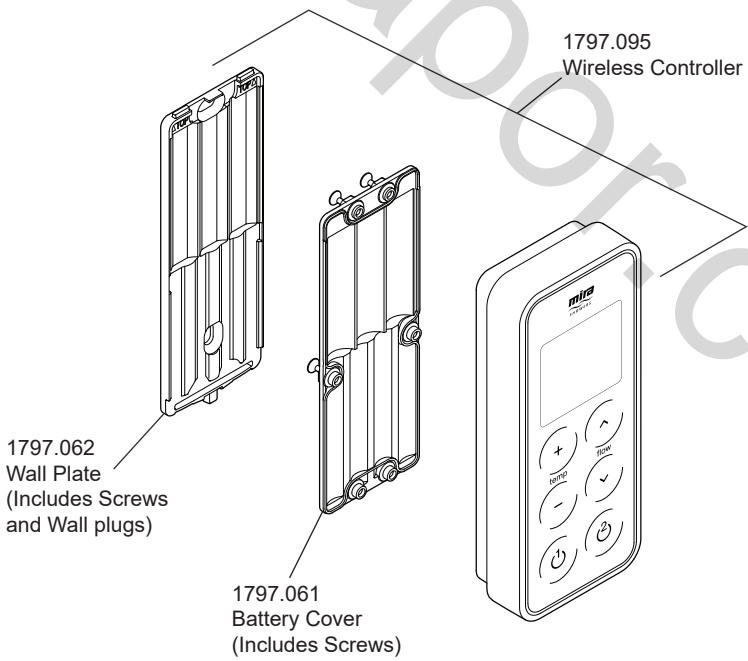

Shower Fittings

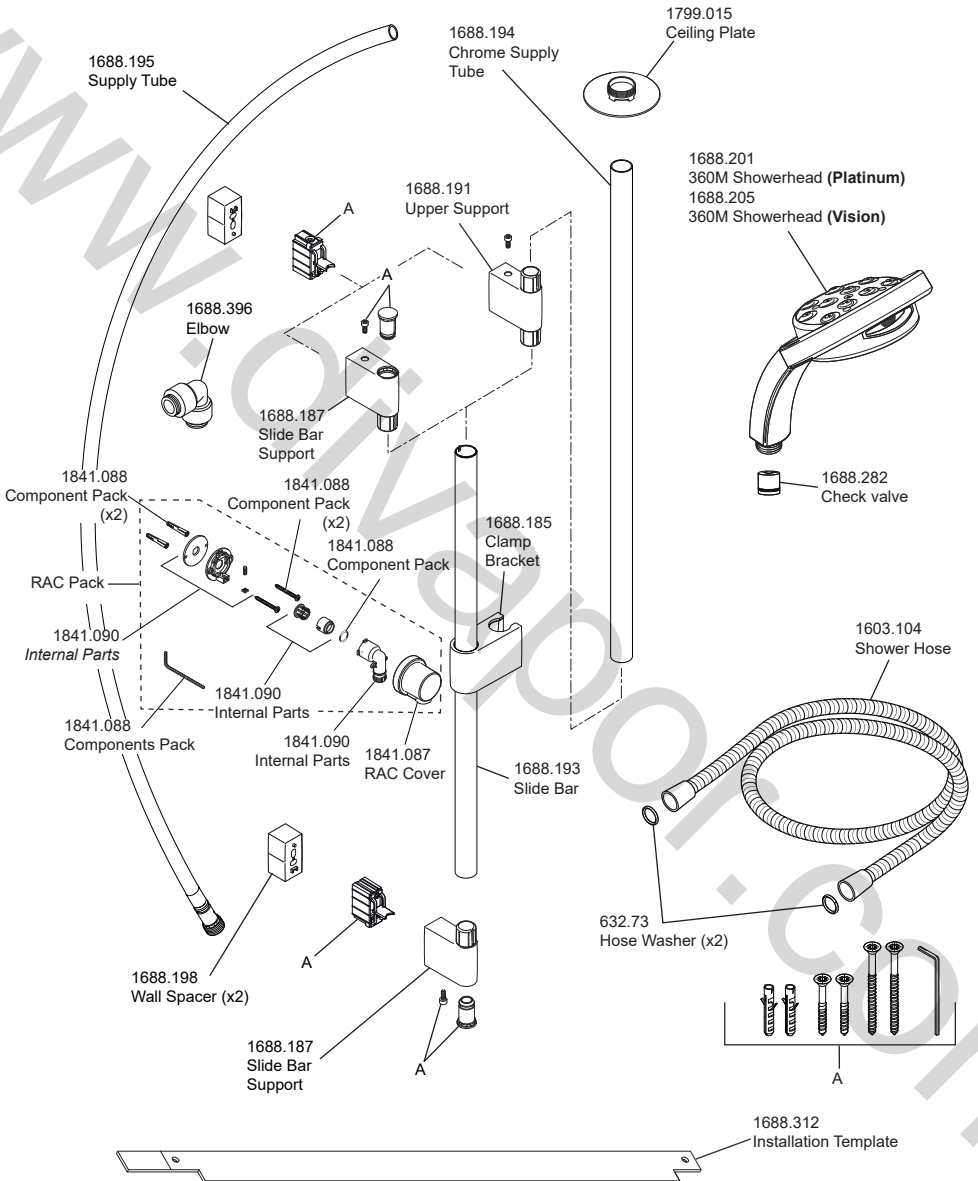

1688.184 Seal and Screw Pack - Components Identified 'B'.
 1688.190 Classic Fittings Component Pack - Components identified 'A'.

Shower Fittings - Deluge Head

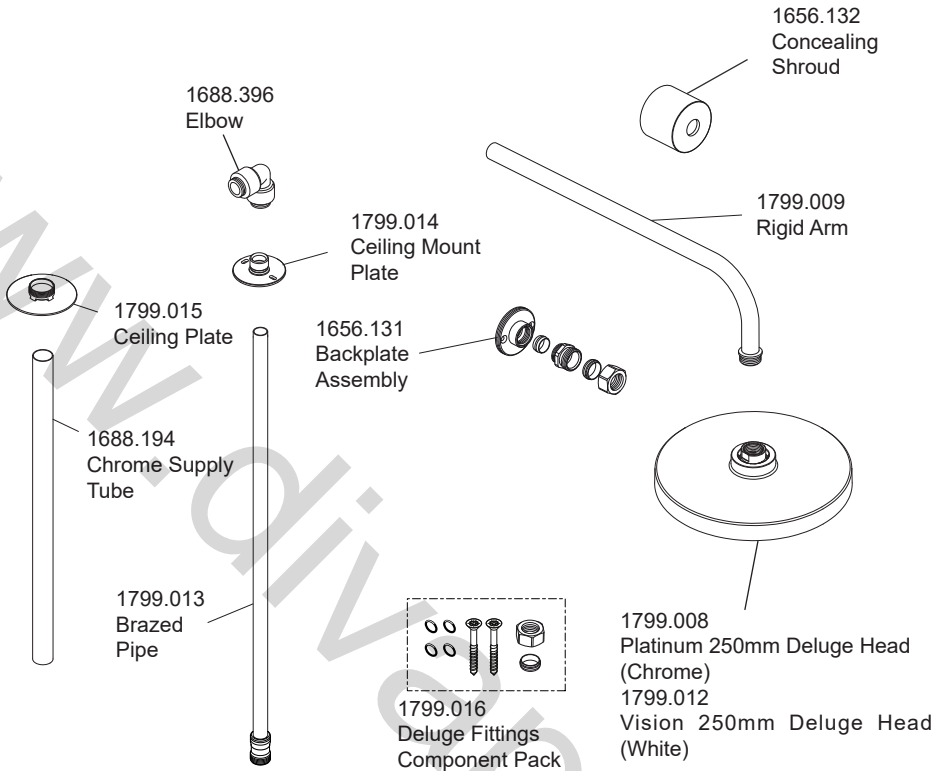

DISPOSAL AND RECYCLING

End of Product Life

Electrical and electronic devices contain a range of materials that can be separated for recycling and used in new products.



This product should not be disposed of with your general household waste. When this product has reached the end of its serviceable life, please remove the batteries and take it to a recognised WEEE (Waste Electrical and Electronic Equipment) collection facility such as your local civic amenity site for recycling.

Your local authority or retailer will be able to advise you of your nearest collection facility.

Batteries

Spent batteries should not be disposed of with your normal household waste. Contact your local authority for information on waste disposal and recycling.

CUSTOMER SUPPORT

Guarantee

Your product has the benefit of our manufacturer's guarantee which starts from the date of purchase. This guarantee only applies in the United Kingdom and Republic of Ireland.

Activating Your Guarantee

Registering your guarantee is quick and simple. To ensure your product is covered, please register online.



Scan the QR code to activate your guarantee now or call 0800 5978551 within 30 days of purchase (UK only).

What is Covered:

- The guarantee applies solely to the original installation under normal use.
- The product must be installed and maintained in accordance with the instructions given in this guide.
- Servicing must only be undertaken by us or our appointed representative.
- Repair under this guarantee does not extend the original expiry date. The guarantee on any replacement parts or product ends at the original expiry date.
- For shower fittings or consumable items we reserve the right to supply replacement parts only.

The guarantee does not cover:

- Call out charges for non product faults (such as damage or performance issues arising from incorrect installation, improper use, inappropriate cleaning, lack of maintenance, build up of limescale, frost damage, chemical attack, corrosion, system debris or blocked filters) or where no fault has been found with the product.
- Water or electrical supply, waste and isolation issues.
- Routine maintenance or replacement parts to comply with the requirements of Building / Plumbing / Electrical Standards or Schemes.
- Compensation for loss of use of the product or consequential or indirect loss of any kind.
- Damage or defects caused if the product is repaired or modified by persons not authorised by us or our appointed representative.
- Accidental or wilful damage.
- Products purchased ex-showroom display.
- Disinfection or descaling to reduce bacterial growth or contamination.

What to do if something goes wrong

If your product is not working correctly please refer to this manual for fault diagnosis and to check that it is installed and commissioned in accordance with our instructions. If this does not resolve the issue, our Customer Services team are here to help get you back up and running. To help us solve your problem quickly, please have your product name, power rating (if applicable) and date of purchase to hand.

Visit www.mirashowers.co.uk

Visit our website to register your guarantee, book a service visit, diagnose faults and purchase products.

Spares and Accessories

We stock a full range of spare parts and fittings and are all available to purchase either online or over the phone. Our online spare parts selector tool will help you quickly and easily identify the spare part for your product.

Visit www.mirashowers.co.uk/parts-accessories

Replacements and Repairs

In the unlikely event that your product needs a repair, our nationwide repairs and installation team are here to help. You can book a convenient date and time online.



Scan the QR code to book a service visit now or visit www.mirashowers.co.uk/support/repair-services/repair-service

We also offer a comprehensive replacement service for when your product needs a little refresh, visit our website or contact our team for more information on our replacement services.

Help us improve

Your experience is important to us and your review (whether good, bad or otherwise) will be posted on Trustpilot.com immediately to help other people make more informed decisions.

Visit uk.trustpilot.com/review/www.mirashowers.co.uk

Need to get in touch?

UK

T: 0800 001 4040
E: askus@mirashowers.com
www.mirashowers.co.uk

Eire

T: 01 531 9337
E: customerserviceire@mirashowers.com
www.mirashowers.ie

Mira is a registered trade mark of Kohler Mira Limited.

The company reserves the right to alter product specifications without notice.

Registered Office:
Cromwell Road,
Cheltenham,
Gloucestershire
GL52 5EP

EU Importer address
K/E S.A.S.
3 rue de Brennus,
93631, La Plaine Saint-Denis,
France



mira
SHOWERS