

320

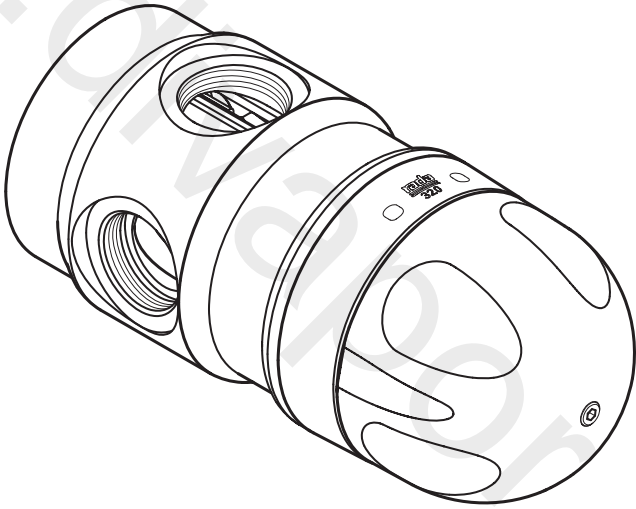

General

1. Make sure that the item is installed by a competent installer.
2. Shut off the main water supply.
3. Observe all local plumbing and building codes.
4. Provided that the thermostatic mixing valve is installed, commissioned, operated within the specification limits and maintained according to this Manual, the risk of malfunction, if not eliminated, is considerably reduced.

Safety

The use of the word 'failsafe' to describe the function of a thermostatic mixing valve is both incorrect and misleading. In keeping with every other mechanism it cannot be considered as being functionally infallible.

Malfunction of thermostatic mixing valves is almost always progressive in nature and will be detected by the use of proper temperature checking and maintenance routines.

Certain types of system can result in the thermostatic mixing valve having excessive 'dead-legs' of pipework. Others allow an auxiliary cold water supply to be added to the mixed water from the mixing valve. Such systems can disguise the onset of thermostatic mixing valve malfunction.

Ultimately, the user or attendant must exercise due diligence to ensure that the delivery of warm water is at a stable, safe temperature. This is particularly important in such healthcare procedures as supervised bathing of patients unable to respond immediately to unsafe temperatures.

To ensure continued safe operation of this product, all '**Critical Components**' should be changed every **5 years**.

However, when supply conditions or usage patterns do not conform to the recommended operating parameters the cartridge may need to be replaced more frequently in line with appropriate risk assessments.

The designed service life of all critical components used in this product is 5 years providing the Rada 320 is operated within the recommended operating conditions and parameters. However when supply conditions and/or usage patterns do not conform to the recommended operating parameters and/or conditions the critical components may need to be replaced more frequently (refer to 'Specification').

Important! In healthcare applications such as hospitals, aged person facilities, residential care homes, etc. and in any other applications where the user is similarly at risk, irrespective of supply and usage conditions or the evidence of in-service tests, the critical components must be replaced at intervals of no more than 5 years.

Critical Component Table	
Part Number	Description
414.51	Cartridge Assembly
1847.232 and 1847.233	Check Valves (where applicable)



320 IC

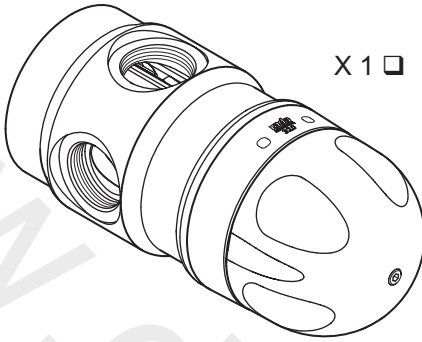

X 1 □

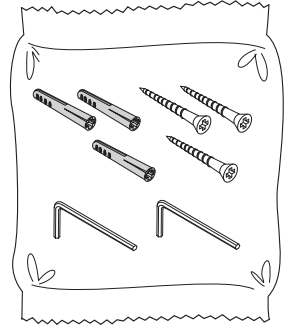

X 1 □

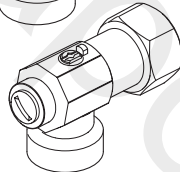
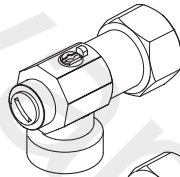
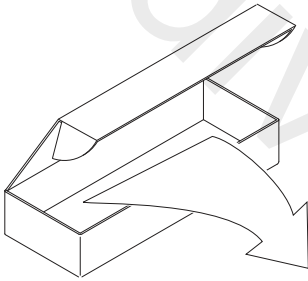

X 2 □

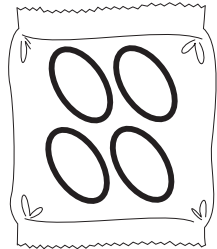

X 1 □

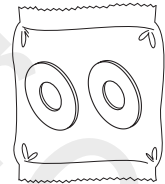
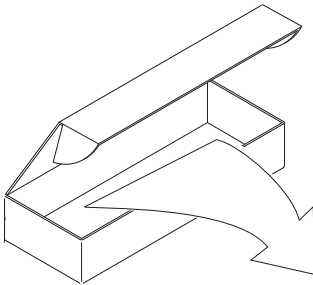

X 1 □

X 1 □

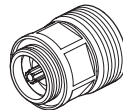

X 1 □

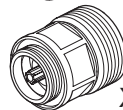
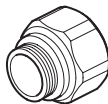

X 2 □

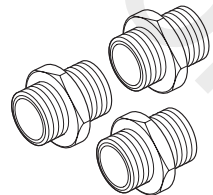

X 3 □

320 IF

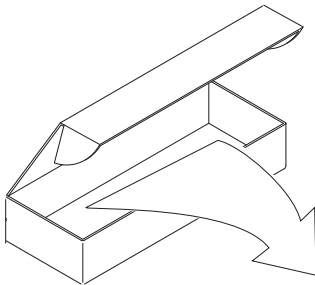
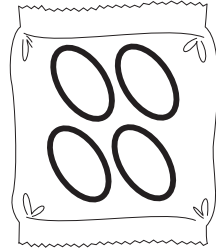
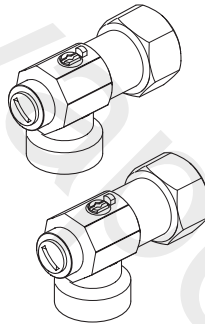
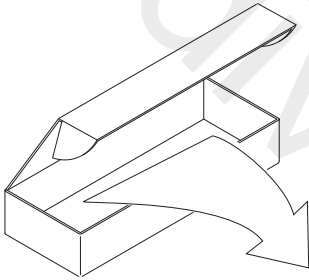
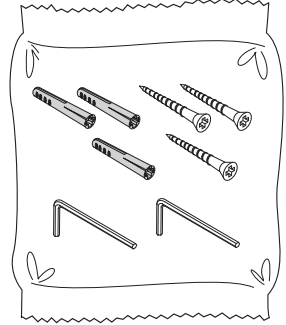
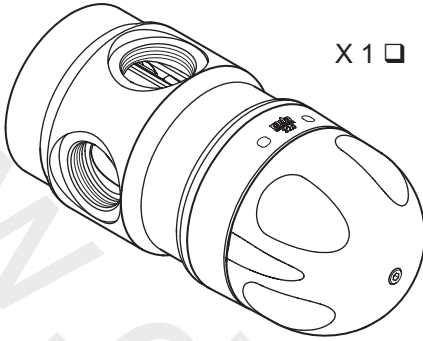

X 1 □

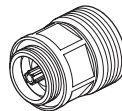

X 1 □

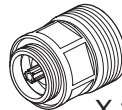
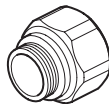

X 2 □

320 F

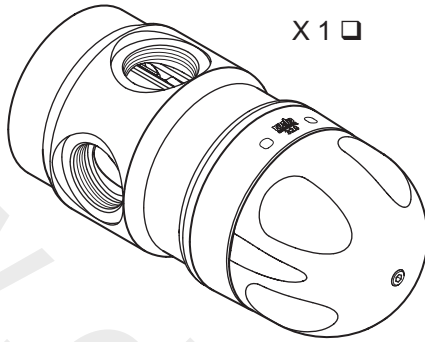

X 1 □

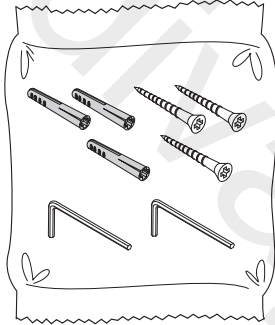

X 1 □

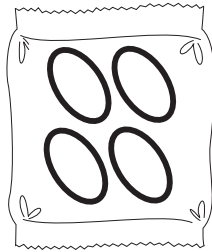

X 1 □

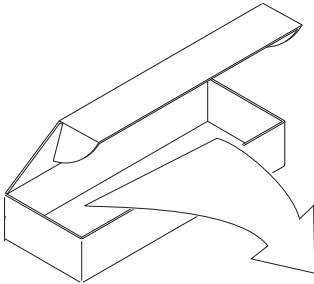

X 1 □

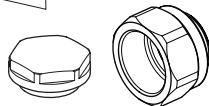

X 3 □

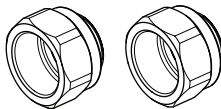

320 M

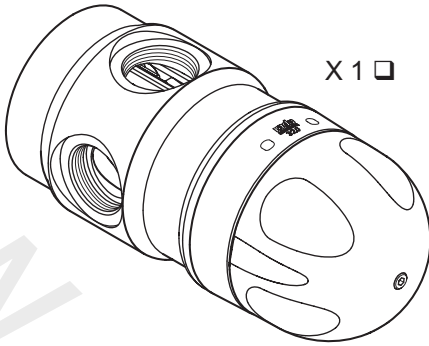

X 1 □

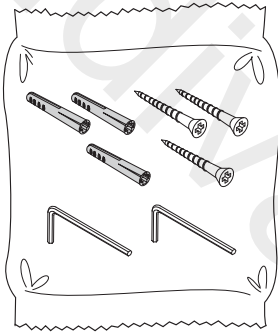

X 1 □

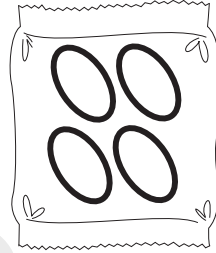

X 1 □

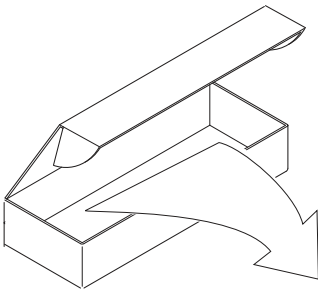

X 1 □

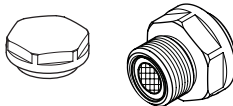

X 3 □

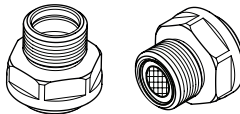

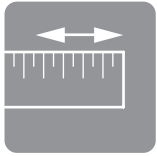

320 IC

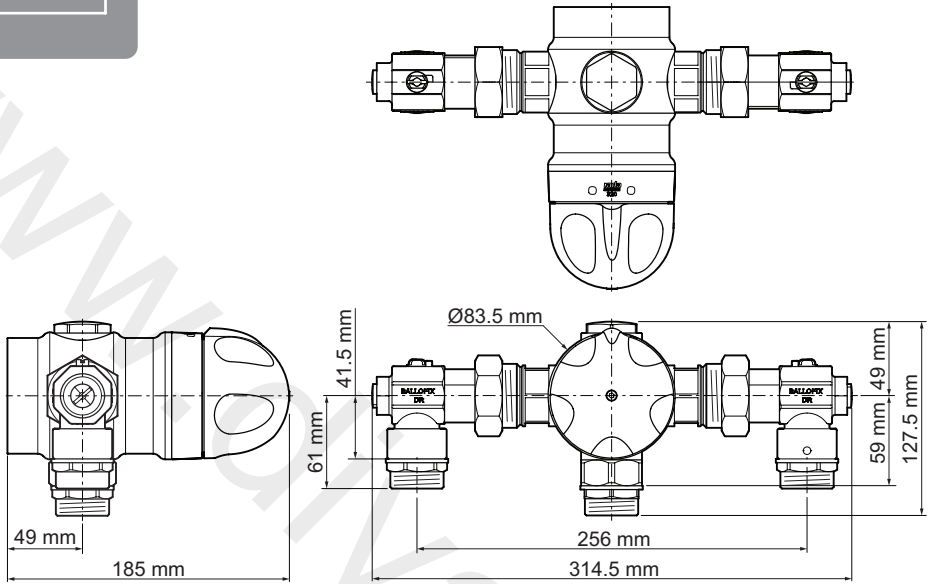

320 IF

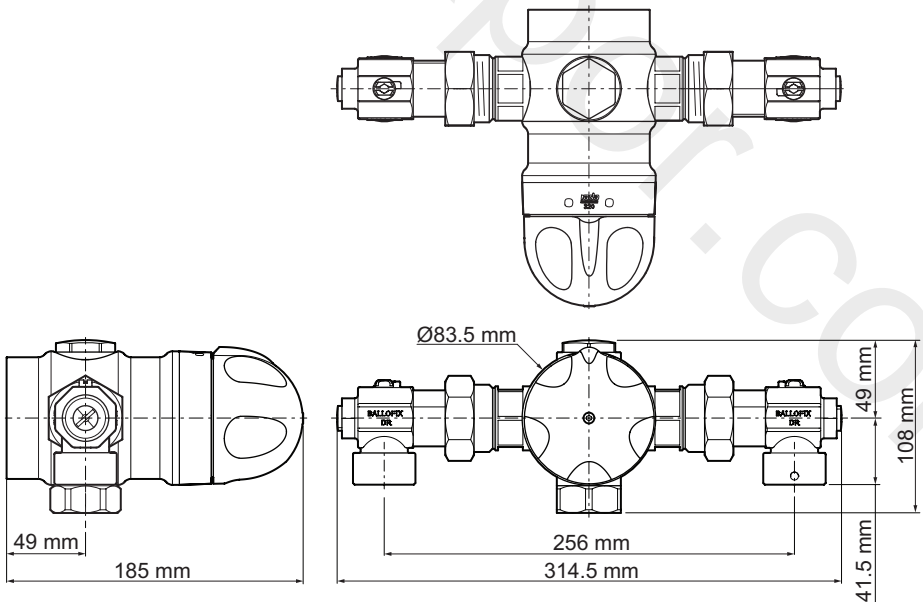

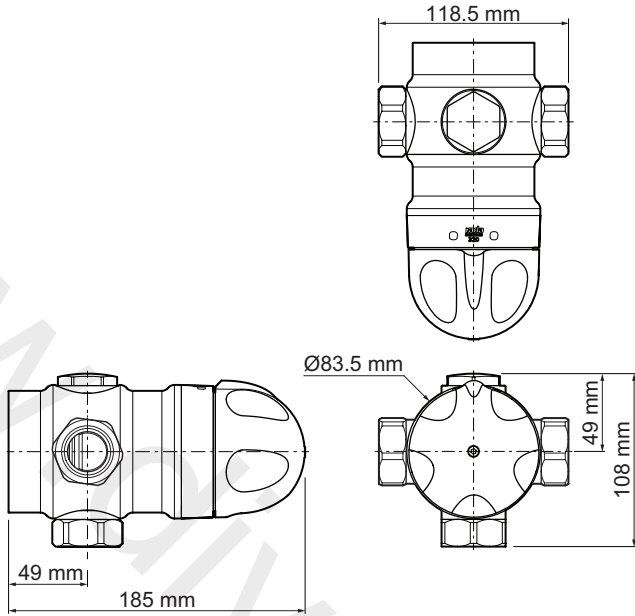
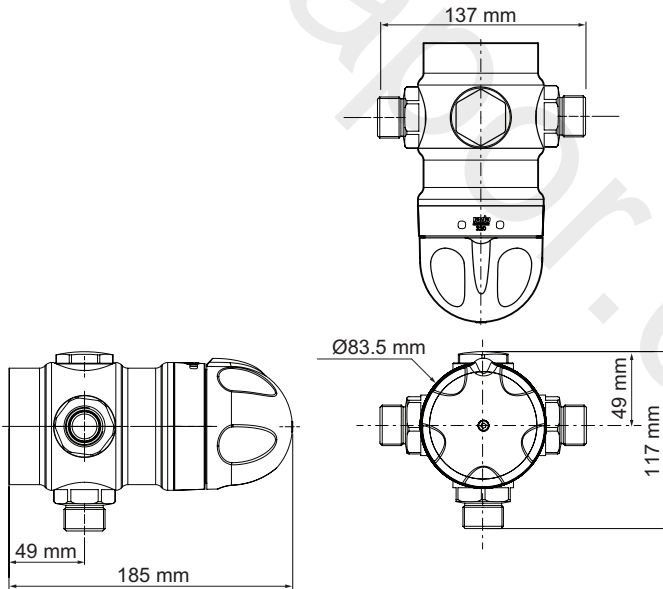
320 F**320 M**

Specification

Normal Operating Conditions are considered as:

- inlet dynamic pressures nominally balanced to within 10% of each other during flow.
- a differential of 15-35°C between the blend setting and either supply.
daily usage of 1-6 hours.
- installation and usage environment not subject to extremes of temperature, unauthorised
- tampering or wilful abuse.

Other Applications

For information on other specific applications or suitability, refer to:

rada_technical@mirashowers.com, or Local Agent.

Disinfection

In applications where system chemical disinfection is practised, chlorine can be used (calculated chlorine concentration of 50 mg/l (ppm) maximum in water, per one hour dwell time, at service interval frequency). Such procedures must be conducted strictly in accordance with the information supplied with the disinfectant and with all relevant Guidelines/Approved Codes of Practice.

If in any doubt as to the suitability of chemical solutions, refer to:

rada_technical@mirashowers.com, or Local Agent.

Operating Parameters

Pressures

Minimum Dynamic Supply Pressure: **0.1 bar**

Maximum Dynamic Pressure: **8 bar**

Maximum Supply Static Pressure: **10 bar**

Maximum pressure loss ratio*: should not exceed 10:1 in favour of either supply during flow.

Maximum pressure loss: inlets to outlet is 5.6 bar, which equates to maximum 120 l/min flow rate at mid blend.

Note! Pressure loss is the pressure drop between the inlets and the outlet of the mixing valve when flow is taking place.

* Pressure Loss Ratio is determined by subtracting the resistance of the outlet pipework and outlet fittings from the dynamic pressures of the hot and cold water at the inlets of the mixing valve. This is at its extreme when the mixing valve is used at its lowest flow-rate and when the maximum inequality occurs in the pressure of the hot and cold water supplies.

Flow Rate/Pressure Loss Graph

Flow Rate/Pressure Loss Graph

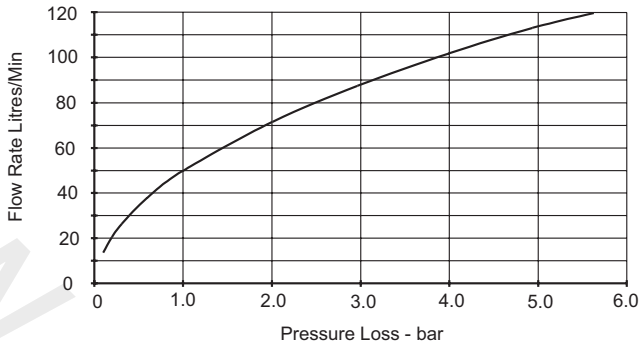

Connections

320 IC - Inlets & outlet connections: 28mm compression.

320 IF - Inlets & outlet connections: 1" BSP female thread.

320 F - Inlet & outlet adaptors 1" BSP female thread.

320 M - Inlet & outlet adaptors 3/4" BSP male thread.

Temperature

Minimum Cold Water Temperature: **1°C**

Maximum Hot Water Temperature: **70°C***

Factory Preset: **43°C** under ideal installation conditions

Optimum Thermostatic Control Range: **35°C - 46°C**

***Note!** For optimum performance reasons it is recommended that the maximum hot water temperature is limited to **65°C**.

Caution! During thermal disinfection the mixing valve can operate up to **85°C** for short periods. Ensure safety precautions are followed during discharge. Chemical disinfection agents e.g. chlorine/chloramines combined with higher temperatures will affect the life of the product adversely and could detrimentally affect the thermostatic performance.

Flow Rates

Minimum Flow Rate: **6 l/min** at mid blend with nominally equal supply pressures.

Maximum Flow Rate: **120 l/min**

Flow Control

Rada 320 mixing valves do not have integral flow control; appropriate provision must be made for this in the outlet pipework. This can be in the form of a stop-cock, mechanical timed-flow controller, solenoid or basin/bath tap. The device chosen must be non-concussive in operation.

Installation

1. Installations must comply with all Local/National Water Supply Authority Regulations/ Byelaws and Building and Plumbing Regulations.
2. The mixing valve should be positioned for easy access during use and maintenance. All routine maintenance procedures can be conducted with the mixing valve body in place. For all models, allow a minimum 100 mm clearance in front of the temperature control to enable removal of the cartridge assembly during maintenance.
3. Conveniently situated isolating valves must be provided for maintenance (not applicable for cx version as isolators are supplied).
4. The use of supply-line or zone strainers will reduce the need to remove debris at each mixing valve point. The recommended maximum mesh aperture dimension for such strainers is 0.5 mm.
5. Inlet and outlet pressure tapings should be provided to enable continuing accurate assessment of operating conditions. This is especially important in healthcare applications.
6. Pipework must be rigidly supported.
7. Pipework dead-legs should be kept to a minimum. The mixed water outlet piping should not exceed 2 m and the overall length from the hot water circuit to the discharge point should not exceed 5 m.
8. Supply pipework layout should be arranged to minimise the effect of other outlet usage upon the dynamic pressures at the mixing valve inlets.
9. Inlet and outlet threaded joint connections should be made with PTFE tape or liquid sealant. Do not use oil-based, non-setting jointing compounds.
10. To eliminate pipe debris it is essential that supply pipes are thoroughly flushed through before connection to the mixing valve.
11. Inlet isolators must be used in the fully open position.
12. Do not install the Rada 320 valve in a position where it may become frozen.

Outlet Position/Reversed Inlets

All Rada 320 mixing valves are supplied with the inlet connections configured **hot - left, cold - right**, and **top outlet** as standard

Should the existing hot and cold pipework make this configuration inconvenient then remove the cartridge assembly and turn it through 180° (refer to **MAINTENANCE** for cartridge removal and re-assembly).

If a bottom outlet position is required, remove the blanking cap from the bottom of the valve and replace it with the fitting from the top of the valve. Then fit the blanking cap to the top of the valve.

Note! The 320 valve is available in a number of variants to suit your particular application. Primarily the installation procedure for the 320 IC valve is shown. Most of the procedural steps are very similar for all variants.

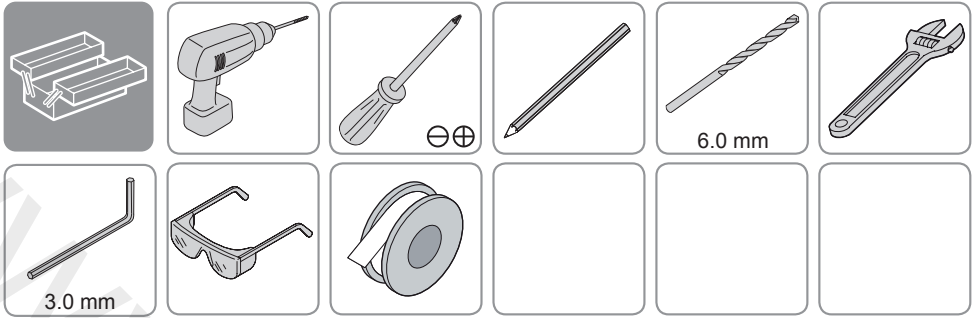

1

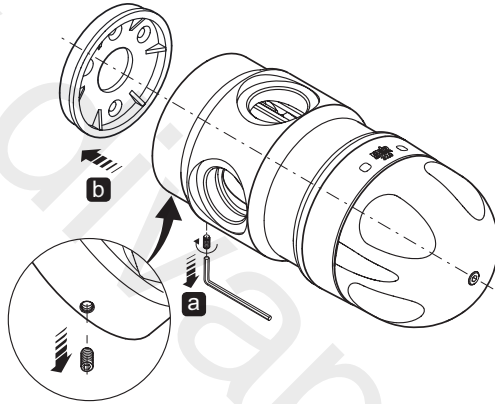

2

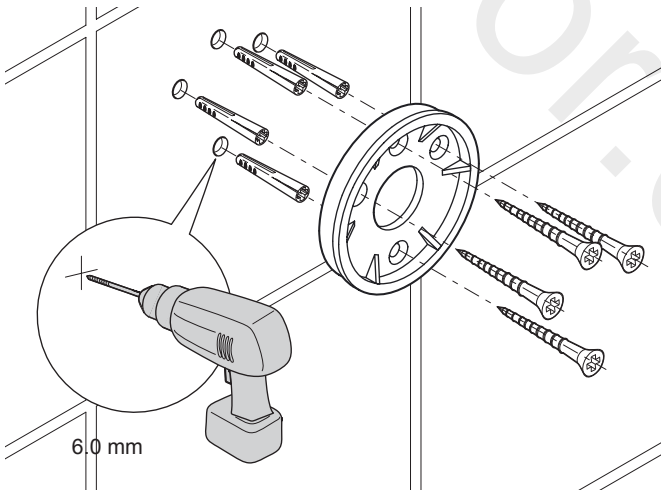

3

Install the connections

320 IC

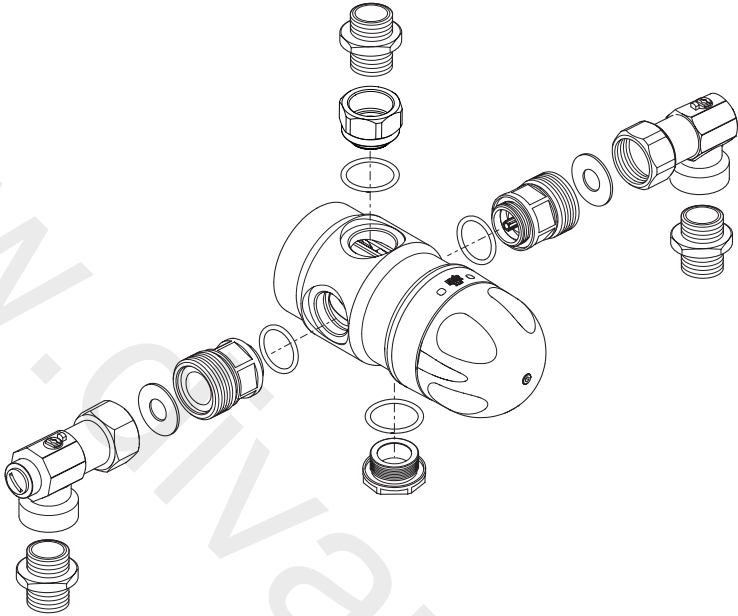

320 IF

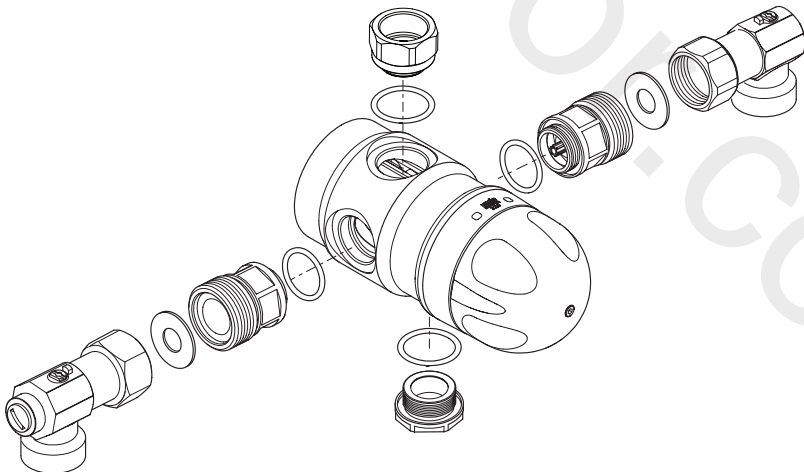

320 F

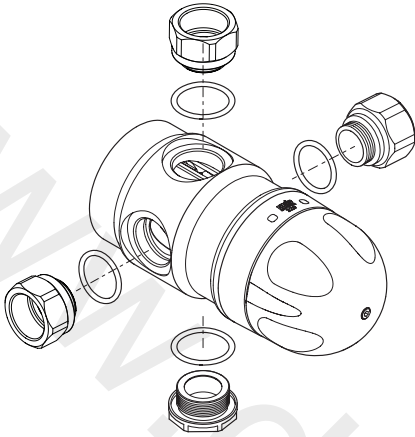

320 M

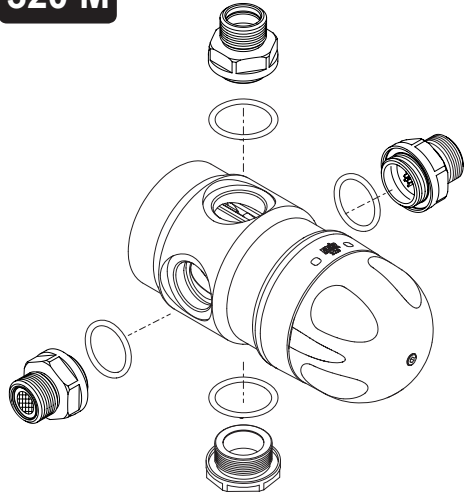

4

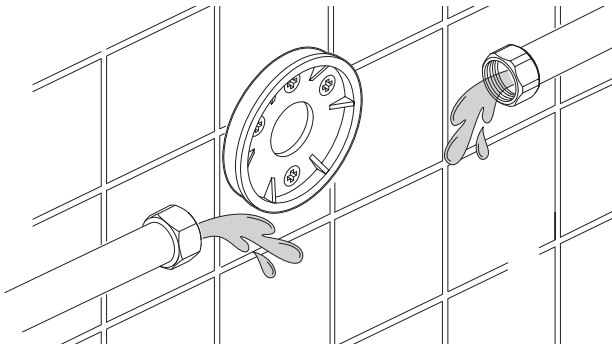
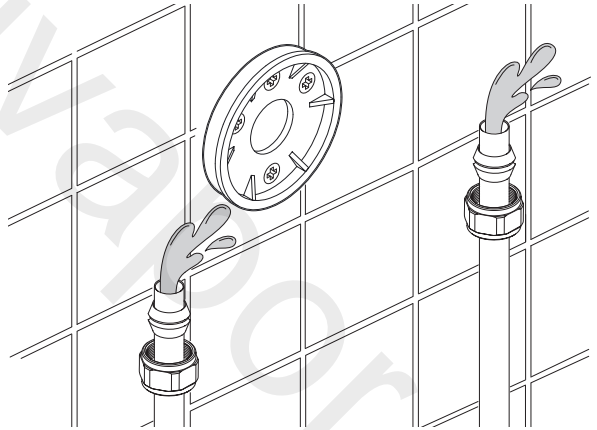
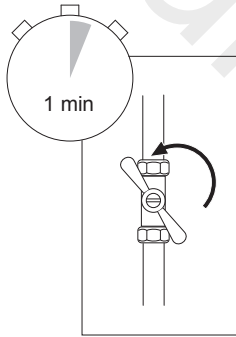

5

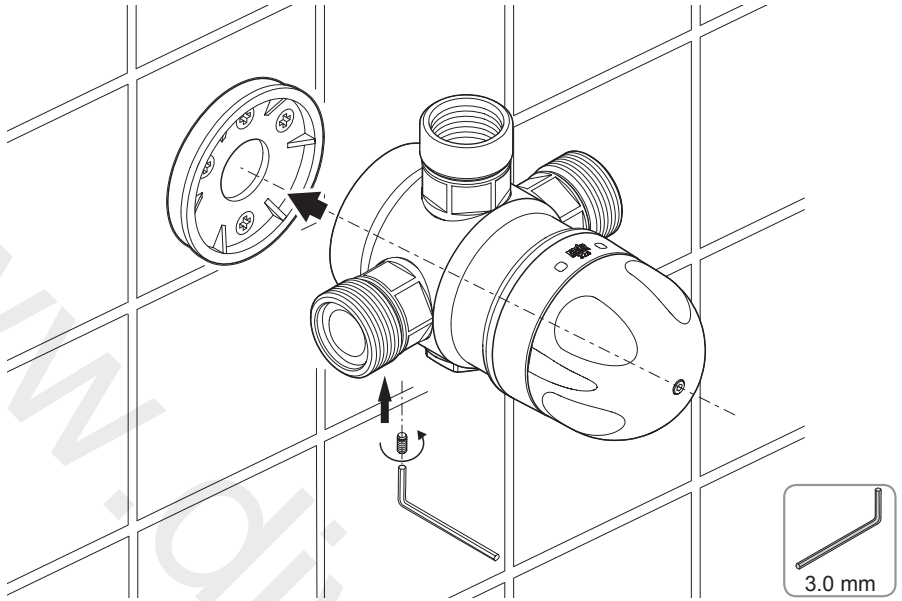

6

Install the pipework

a

320 IC

320 IF

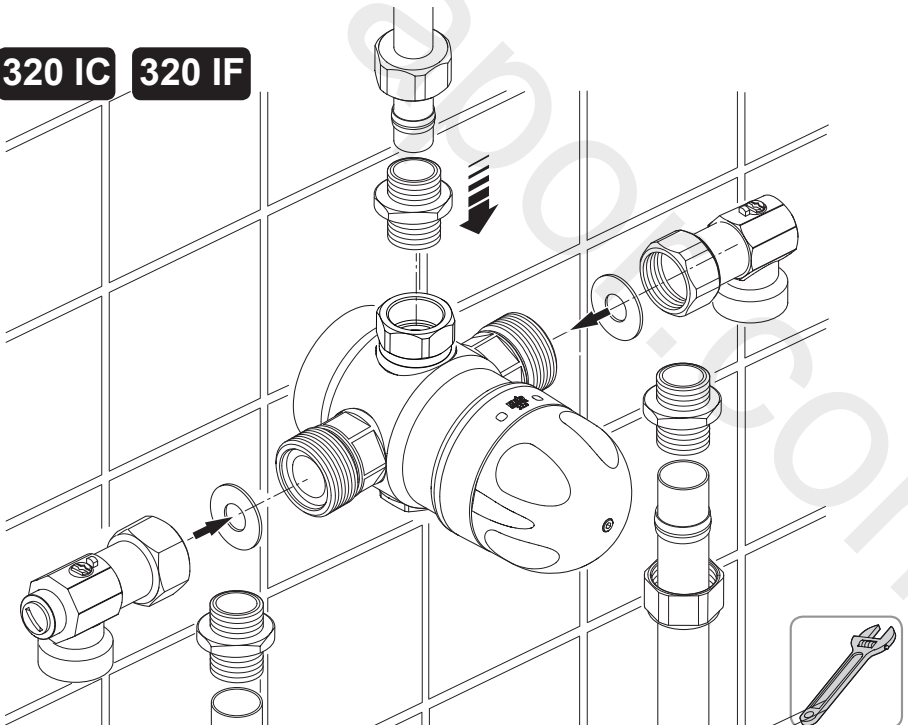

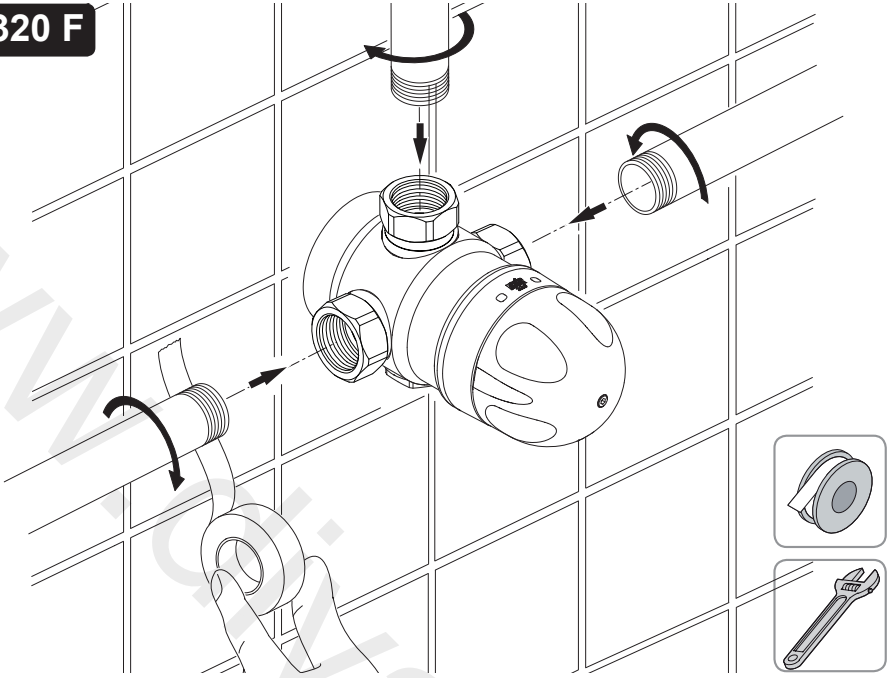
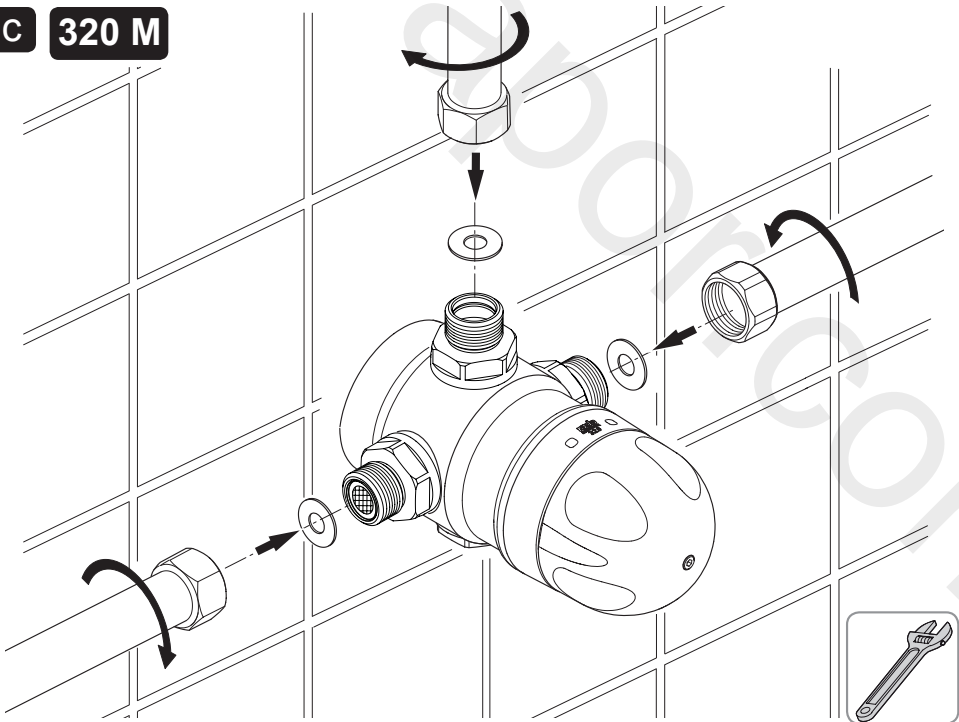
b 320 F**c 320 M**

7

320 IC shown. The rest of the installation procedure is similar for all variants of the 320 valve.

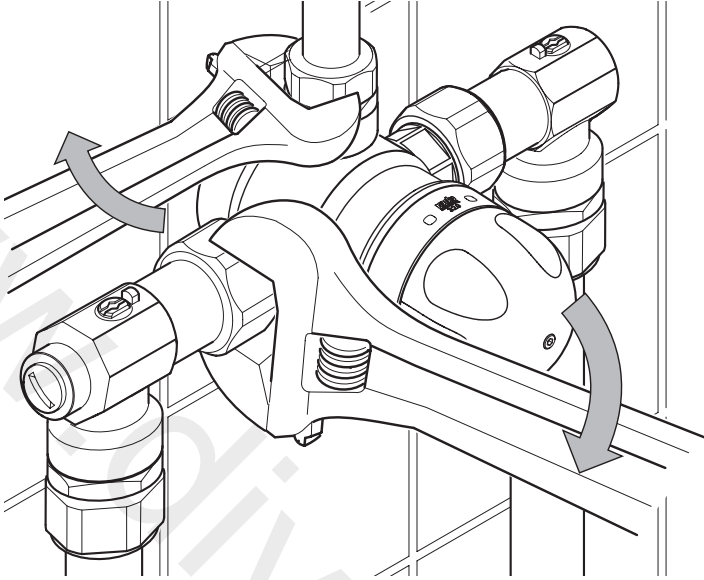

8

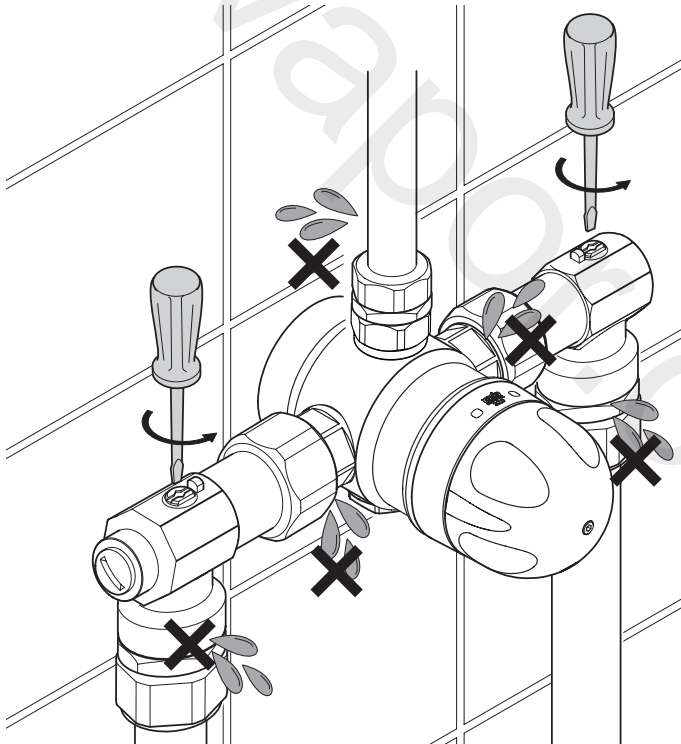

Commissioning

Commissioning must be carried out in accordance with these instructions, and must be conducted by designated, qualified and competent personnel.

Exercising the Thermostat

Thermostatic mixing valves with wax thermostats are inclined to lose their responsiveness if not used. Valves which have been in storage, installed but not commissioned, or simply not used for some time should be exercised before setting the maximum temperature or carrying out any tests.

A simple way to provide this exercise is:

1. Ensure that the hot and cold water are available at the valve inlets, and the outlet is open.
2. Move the temperature control rapidly from cold to hot and hot back to cold several times, pausing at each extreme.

Maximum Temperature

The maximum blend temperature obtainable by the user should be limited, to prevent accidental selection of a temperature which is too hot.

All Rada Thermostatic mixing valves are fully performance tested individually and the maximum temperature is pre-set to approximately 43°C under ideal installation conditions at the factory.

Site conditions and personal preference may dictate that the maximum temperature has to be re-set following installation.

Maximum Temperature Setting

Check that an adequate supply of hot water is available at the **hot** inlet of the mixing valve.

The minimum temperature of the hot water must be at least 15 °C above the desired blend, however, during resetting this should be close to the typical storage maximum to offset the possibility of any blend shift due to fluctuating supply temperatures.

Check that both inlet isolating valves are fully open (If installed).

Temperatures should always be recorded using a thermometer with proven accuracy.

For Adjustable Temperature

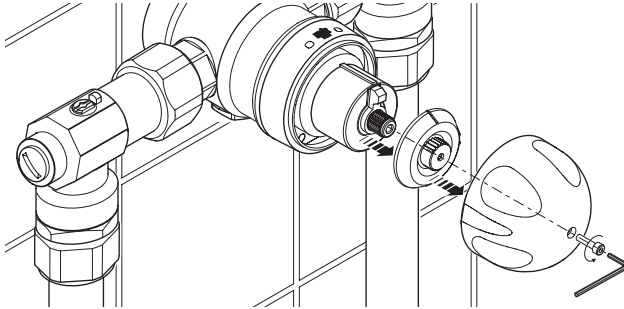

1. Remove the concealing cap, temperature knob and then the screw using the 3 mm hexagonal wrench (supplied). Remove the temperature knob and the hub.

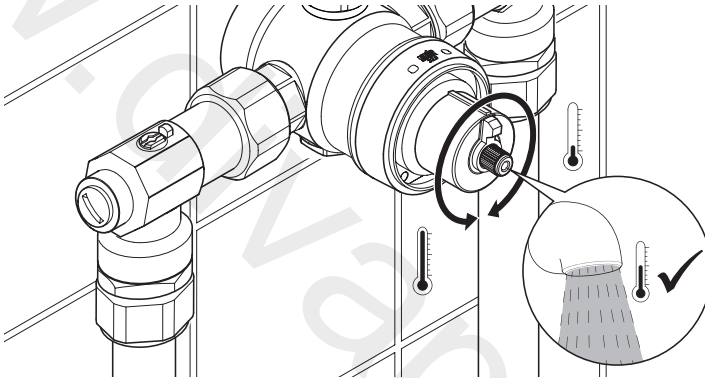

2. Rotate the spindle until required blend temperature is obtained at outlet point (**clockwise = decrease temperature, anticlockwise = increase temperature**).

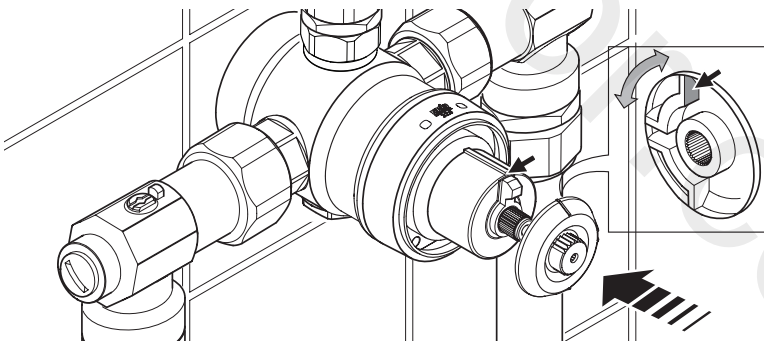

3. Once the desired maximum blend temperature is achieved, re-fit the hub without disturbing the spindle: Position the hub so that the hub stop comes up against the cartridge stop preventing any further rotation in an anti-clockwise direction. Check that blend temperature has not altered.
4. Refit the temperature knob. Make sure that the indicator points to 9 o'clock.

For Locked Temperature

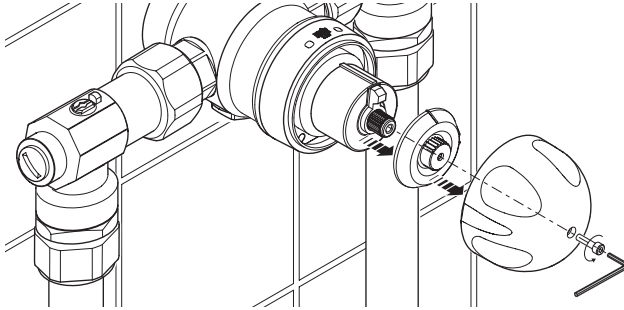

1. Remove the concealing cap, temperature knob and then the screw using the 3 mm hexagonal wrench (supplied). Remove the temperature knob and the hub.

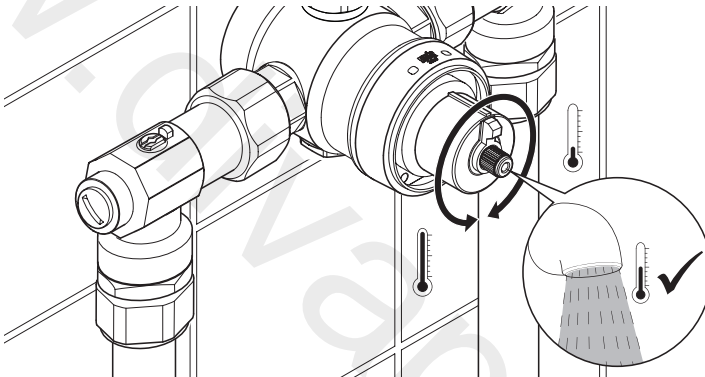

2. Rotate the spindle until required blend temperature is obtained at outlet point (**clockwise = decrease temperature, anticlockwise = increase temperature**).

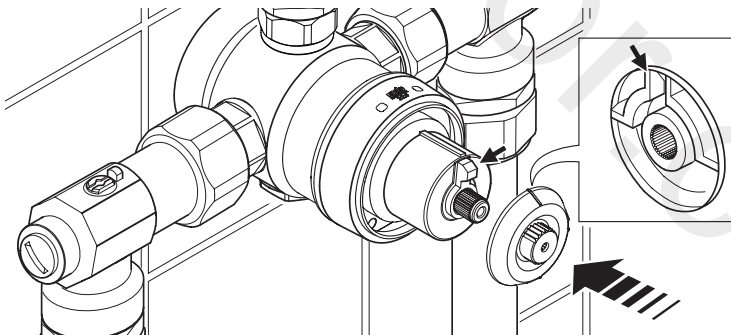

3. Once the desired maximum blend temperature is achieved, re-fit the hub without disturbing the spindle, positioning it so that the centre stop slot in the hub fits over the top of the cartridge stop, preventing any further rotation in either direction. Check that the blend temperature has not altered.
4. Refit the temperature knob. Make sure that the indicator points to 6 o'clock.

Commissioning Checks

(Temperatures should always be recorded with a thermometer with proven accuracy).

1. Check inlet pipework temperatures for correct function of checkvalves i.e. that hot water does not cross flow into the cold supply and vice versa.
2. Check that the supply pressures are within the range of operating pressures for the valve.
3. All connections and the mixer body are water tight.
4. Exercise the thermostat.
 - (a) ensure that the hot and cold water are available at the valve inlets, and the outlet is open.
 - (b) move the temperature control rapidly from cold to hot and hot back to cold several times, pausing at each extreme.
5. Adjust the temperature of the mixed water in accordance with the instructions (refer to Maximum Temperature Setting).
6. Operate the outlet flow control and check:
 - (a) Flow rate is sufficient for the purpose
 - (b) Temperature(s) obtainable are acceptable.

It is advisable to establish a performance check at this time, which should be noted for future reference as part of a Planned Maintenance Programme. The procedure should be chosen to imitate both typical and difficult operating conditions, such as any supply pressure fluctuations that may be likely. An ideal method is to locate another outlet on the common cold water supply close to the mixing valve (operating this outlet should cause a drop in supply pressure), and note the subsequent effect on blend temperature (should be no more than 2°C change).

Operation

For models with knob fitted for adjustable temperature control, adjustment of blend temperature from preset maximum to cold is achieved by clockwise rotation of the knob.

For models with locked temperature control, no user adjustment is intended.

Control of flow is via separate outlet valve(s), refer **Flow Control**.

The product is suitable for a number of bathing applications. Ultimately, the user or attendant must ensure that the delivery of warm water is at a stable, safe temperature. This is particularly important in healthcare procedures such as supervised bathing of patients unable to respond immediately to unsafe temperatures.

If temperatures are found to be unstable or unsafe the product must be isolated and not used until product maintenance checks have been carried out in accordance with the instructions given in this manual.

Troubleshooting

1. Only hot or cold water from outlet

- Inlet supplies reversed (i.e. hot supply to cold inlet). Check.
- No hot water reaching mixing valve. Check.
- Check filters and inlet fittings for blockage.
- Installation conditions continuously outside operating parameters. refer to **Specification**.

2. Fluctuating or reduced flow rate

- Check filters and inlet / outlet fittings for flow restriction (check isolators are fully open).
- Ensure that minimum flow rate is sufficient for supply conditions.
- Ensure that dynamic inlet pressures are nominally balanced.
- Ensure that inlet temperature differentials are sufficient.
- Check thermostatic performance; renew cartridge assembly if necessary.

3. No flow from mixing valve outlet

- Check inlet isolators are fully open.
- Check filters and inlet / outlet fittings for blockage.
- Hot or cold supply failure.

4. Blend temperature drift

- Refer to symptom **2** above.
- Hot supply temperature fluctuation (rectify and refer to **Commissioning**).
- Supply pressure fluctuation (refer to **Installation**)

5. Hot water in cold supply or vice versa

Indicates check valve require maintenance, refer to **Maintenance**.

Note! Some 320 variants are not supplied with checkvalves. Therefore, in-line checkvalves may require maintenance. These may be away from the product.

6. Maximum blend temperature setting too hot or too cool

- Indicates incorrect temperature setting. Refer to **Commissioning**.
- As symptom **4** above.
- As symptom **5** above.

7. Water leaking from valve body

Seals worn or damaged.

- Obtain Seal Pack and renew all seals.
- If leak persists from around the temperature spindle, replace the cartridge assembly.

Maintenance

General

1. The maintenance of this product must be carried out in accordance with instructions given in this Manual, and must be conducted by designated, qualified and competent personnel.
2. Rada products are precision-engineered and should give continued superior and safe performance, provided:
 - They are installed, commissioned, operated and maintained in accordance with the recommendations stated in this Product Manual.
 - Periodic attention is given as necessary to maintain the product and its associated installation components in good functional order. Guidelines are given below.
3. The use of main supply-line or zone strainers (recommended maximum mesh aperture dimension is 0.5 mm) will reduce the need to remove debris at each mixing valve point.

All the mixing valves in this series have functional parts (except the temperature or locking knob) contained within service-free cartridges, so any maintenance requirement is reduced to temperature, performance and functional checks and inspection, with cartridge renewal when necessary. In larger installations with a number of mixing valves, it is good policy to maintain a small stock of spare cartridges so that no mixing valve or facility need to be out of commission for more than the time it takes to exchange the cartridge, and also, eventually, a rolling programme of cartridge renewal can be undertaken as part of a planned maintenance procedure.

Planned Maintenance Programmes (Preventative/Precautionary Maintenance)

The frequency and extent of attention required will vary according to prevailing site and operational conditions. In applications (such as non-healthcare) where the risks to the user are too slight to justify the full in-service test procedure and maintenance logging process, the procedure under Performance check is suggested to cover average duty and site conditions. In all other cases it is recommended that a routine of preventative maintenance be employed which is based upon assessment of the risks to the user.

The following practices are intended to support such a routine:

- In-service tests
 - Regular temperature checking in between In-service tests
 - Maintenance of a log of In-service tests and temperature checks together with details of cartridge replacements and any other service work.
1. Thermostatic mixing valves only operate correctly when all components have been serviced and have been tested for correct performance. If any component is faulty, including the thermostat the valve will not operate correctly and could allow full hot water to pass through the valve.
 2. As with all other thermostatic mixing valves, the critical components will wear over a period of time and usage.

Note! refer to the 'Safety' section.

Performance Check

Six Monthly

Exercising the Thermostat: If the valve has not been in regular or recent use the thermostat should be exercised before any other checking. Where user adjustment of the blend temperature is available the exercising of the thermostat can be achieved as described in **COMMISSIONING**. For valves with locked temperature control it is necessary to isolate and restore each supply in turn a few times.

Blend Temperature: check for correct blend setting and/or maximum preset temperature. Reset as necessary.

Performance: check blend stability against known datum (e.g. commissioning check) for an induced pressure or flow change. Renew thermostatic cartridge when necessary.

Function: check inlet pipework temperature for correct function of checkvalves, and maintain/renew as necessary. Check and clean strainers as appropriate. Lubricate accessible seals when necessary using silicone-only based lubricant.

Temperature Testing

Check and record warm water temperature regularly to confirm correct operating performance of the valve. In health care applications such as hospitals, aged persons facility, nursing homes etc. such checks must be made at least every month. More regular temperature checks should be made where increased risks are perceived such as where patients are unable to immediately respond to an increase in water temperature by either shutting the water off or removing themselves from the contact with the water. Records of warm water temperature checks should be included in a log book.

Thermostatic Mixing Valve Performance Records (Log Book)

It is recommended that the user maintains a log of the in-service tests described herein, together with a record of any service work carried out and the replacement of cartridges. It is also recommended that any maintenance personnel sign the user log in respect of all thermostatic mixing valves examined on each attendance at the user's premises.

It is recommended that the Maintenance Log should record the following:

Details of valve, location and use, risk level and instructions

Valve make and model

Valve unique identification number

Valve location

Date installed

Application i.e. type of discharge: bath, shower etc.

Risk assessment report number

Risk level found (e.g. vulnerability of patient)

Frequency of critical component (cartridge) replacement

Frequency of temperature monitoring

Responsibility for temperature monitoring

Location of temperature monitoring records

Source of spares and advice

Issue number of Product Manual (Installation, operating and maintenance instructions).

Details of in-service testing and maintenance

Initial commissioning test data (Supply pressures and temperatures, mixed water temperature, flow rate, result of cold water isolation test, date carried out, signature of maintenance person).

First in-service test due date

First in-service test data (As for initial commissioning)

Details of any remedial work carried out to valve or supply system

Second in-service test due date

Second in-service test data (As for initial commissioning)

Details of any remedial work, including part replacement, carried out to valve or supply system

Next in-service test due date

Next in-service test data (As for initial commissioning)

Details of any remedial work, including part replacement, carried out to valve or supply system.

Note! Local requirements may demand that additional information be recorded.

Training

Maintenance personnel should also ensure that the user's staff are aware of the importance of reporting temperature variations and that when detected, these should be recorded in the log.

Maintenance Procedures

Maintenance must be carried out in accordance with these instructions, and must be conducted by designated, qualified and competent personnel.

This mixing valve series is designed for minimal maintenance under conditions of normal use. External surfaces may be wiped clean with a soft cloth, and if necessary, a mild washing-up type detergent or soap solution can be used.

Warning! Many household and industrial cleaning products contain mild abrasives and chemical concentrates, and should not be used on polished, chromed or plastic surfaces.

Should an internal malfunction occur then this will probably require cartridge renewal. The cartridge assembly and check valves contain no user-serviceable parts, and must not be dismantled.

Components are precision-made, so care must be taken while servicing to avoid damage.

When ordering spare parts, please state product type, i.e. Rada 320 IC, and identify part name and number (refer to **PARTS LIST**). A Seal pack is available, containing all the seals that may be necessary for renewal during maintenance or servicing.

Lubricants

Important! All seals are pre-lubricated. If you need to lubricate the seals, use only a small amount of silicone-only based lubricants on this product. Do not use oil-based or other lubricant types as these may cause rapid deterioration of seals.

Maintenance Procedure - Cartridge Assembly

Removal

1 Turn the isolation screw on the isolator valves through 90° to isolate the water supplies to the valve. Open an outlet fitting to release pressure and to assist the draining of residual water.

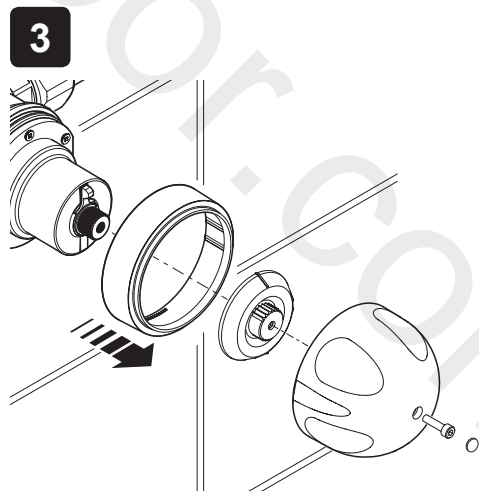
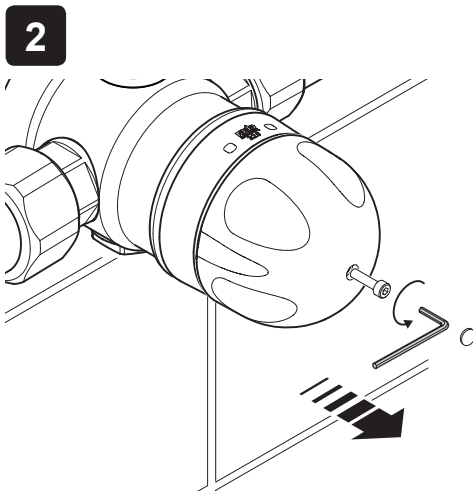

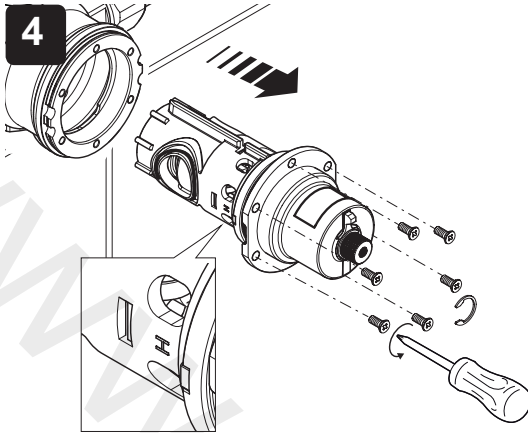

Remove the temperature knob concealing cap and then the screw using the 3 mm hexagonal wrench (supplied). Remove the temperature knob, the temperature indicating ring and the hub.

Remove the six screws holding the cartridge assembly into the body.

Use a suitable tool inserted into the cut-outs to lever the cartridge assembly from the body.

Remove the cartridge assembly from the body.

Cleaning/Renewal of Parts

1. The interior surface of the mixing valve body must be clean before re-fitting the cartridge. Rinse the valve interior thoroughly in clean water to remove any debris before refitting the cartridge.

Note! The body interior must be cleaned carefully and not damaged in any way. Do not use any abrasive material.

2. Cartridges may only be cleaned by flushing through under a jet of clean water to remove debris.

Do not descale. Descaling solution MUST not be used on any parts of the 320 valve. Cartridges are not serviceable, and must not be dismantled.

Cartridges cannot be tested individually, service condition should be assessed as part of the performance check; refer **Commissioning Checks**.

3. Examine all accessible seals for signs of deformation or damage, and renew as necessary, taking care not to damage the seal grooves.

Re-assembly

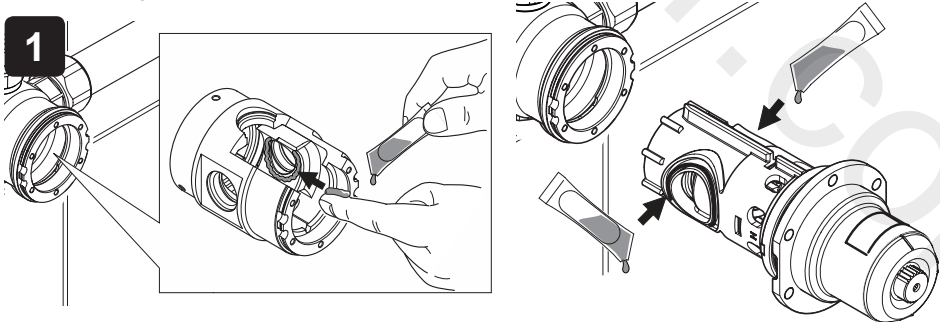

Note! Apply a small amount of silicone based grease to the top and bottom groove that the inlet seals fit to retain them whilst the cartridge is fitted. Fit the inlet seals to the cartridge and apply further grease to the seal faces and to the inside of the body as shown to aid insertion of the cartridge into the body.

2

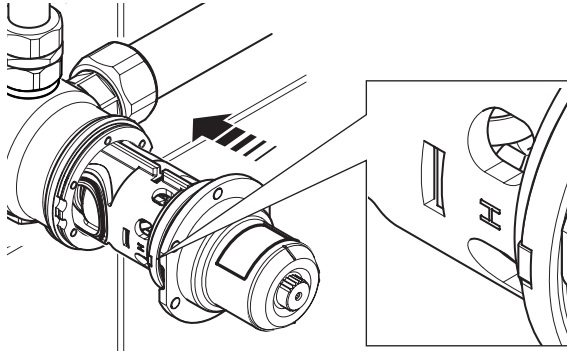

Identify which is the hot inlet to the mixing valve body, and align the cartridge assembly accordingly.

Note! There is a 'H' and 'C' marked on the cartridge. Make sure that the 'H' aligns with the hot inlet and that the 'C' aligns with the cold inlet.

Align the cartridge guides with the slots in the body and carefully push the cartridge assembly back into the body, checking that the 2 cartridge inlet port seals remain in place.

3

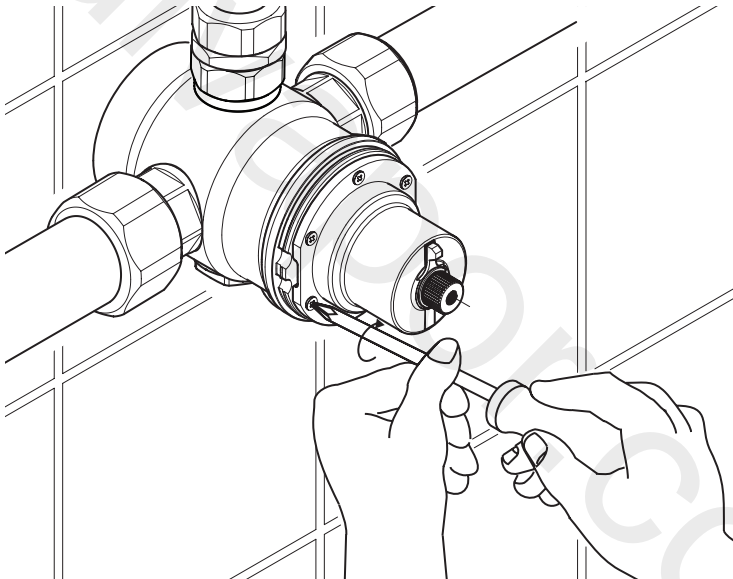

Install the six screws and tighten.

Fit the temperature indicating ring.

Turn the isolation screw on the isolator valves through 90 ° to restore the water supplies to the valve and check for any leaks.

Before fitting the hub, the temperature will need re-setting; refer to **COMMISSIONING**.

Re-fit the temperature knob.

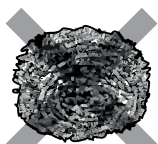
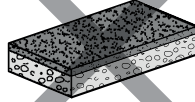
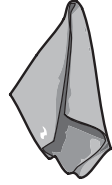
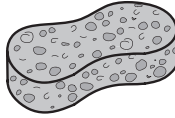

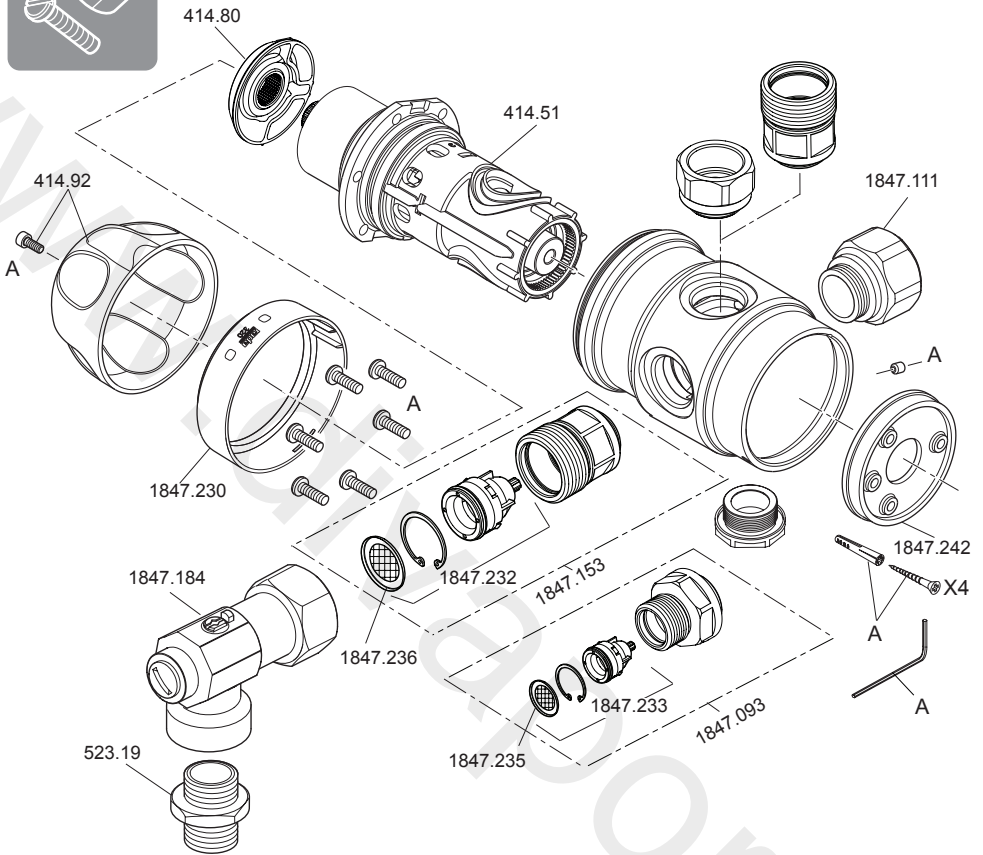

No:	Description
414.51	Cartridge Assembly
414.80	Hub Pack
414.92	Knob Pack
523.19	Compression Fitting
1847.093 (3/4" BSP)	Connector Pack
1847.111 (1" BSP)	Female BSP Pack
1847.153	Elbow Connection Pack
1847.184	Isolating Elbow Pack
1847.227	Seal Pack - Not illustrated
1847.229	Screw Pack - 'A'
1847.230	Indicator Trim
1847.233 (3/4")	Inlet Service Pack
1847.232 (1 - 1/4")	
1847.235 (3/4")	Filter Pack x 2 Filters
1847.236 (1 - 1/4")	
1847.242	Backplate



Your product has the benefit of our manufacturer's guarantee which commences from date of purchase or from the date of commissioning when product commissioning has been conducted by the UK Rada Commercial Field Team (available UK Only).



Please visit www.radacontrols.com or contact your local agent for all terms and conditions including details of the Rada commissioning service for the UK



UK Customer Service & Post Installation enquiries

0844 571 1777

Fax: 01242 282595

Email: radacustomerservices@mirashowers.com

Pre-Specification Enquiries

0844 571 1777

Fax: 01242 282404

E-mail: rada_technical@mirashowers.com

By Post: Rada Controls, Cromwell Road, Cheltenham, Gloucestershire GL52 5EP

To Contact Us: Eire Only

Telephone: 01 531 9337

E Mail: CustomerServiceEire@mirashowers.com