

## RADA VZ1 10 BAR VALVE



- Supplied with 6 l/min flow regulator
- Thermostatic temperature stability
- Fast-fix kit for easy installation
- Works on all systems, even at low pressure
- Separate flow and temperature controls
- Ceramic flow control ensures smooth reliable operation throughout the life of your product
- Simple lever handles are easy to grip and easy to use
- Maximum temperature stop for increased safety (with override for a hotter shower)
- Pipe spacer guide included to aid pipework installation during first fix
- Front of tile installation system allows connection to pipework during second phase fix after tiling is complete



## Specify as:

**Rada VZ1 10 Bar Valve (1.1900.050)**

Surface mounted chrome plated bar valve with separate flow and temperature controls, supplied with a 6 lit/min flow regulator .

## Flow Diagram

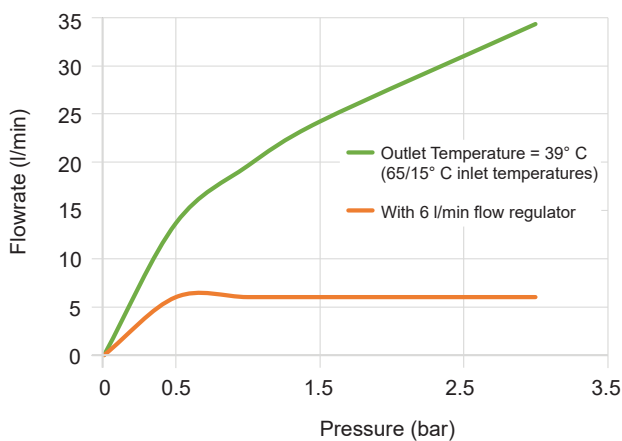

## Dimensions (mm)

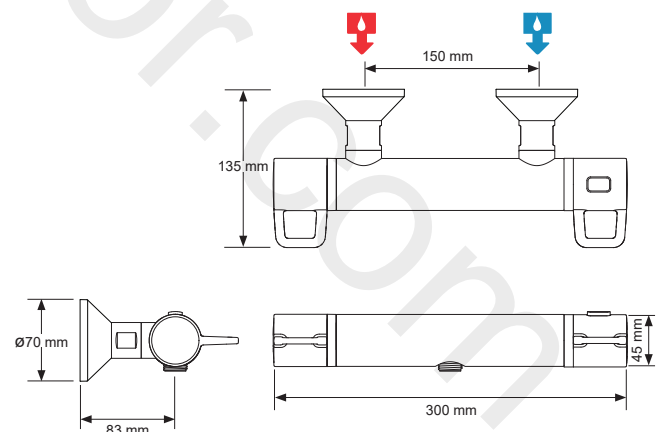

## TECHNICAL SPECIFICATION

### Installation and Maintenance

Please refer to the appropriate Product Manual.

### Connections

Inlet connections: 15mm compression joints with pipes;

¾" BSP connection to mixer shower.

Outlet connections: ½" BSP Male.

### Approvals

NSF International TMV 2 Thermostatic Mixing Valve Scheme approved

HP-S, HP-SE High Pressure Showering

WRAS approved (Water Regulations Advisory Scheme)

Designed, manufactured and supported in accordance with accredited BS EN ISO 9001:2008 Quality Management Systems and BS EN ISO 14001:2004 Environmental Management Systems.

### Operation

The temperature is controlled by rotating the temperature handle. For safety reasons, the temperature is limited by an override stop. To obtain a higher temperature, press the override button on the temperature handle and continue to rotate the handle. The flow is controlled by rotating the flow handle.

### Supply Conditions

Cold water range: 1°C to 25°C.

Hot water range: Min 55°C; 60°C - 65°C (recommended).

Temperature stability: ± 2°C

Minimum temperature differential of blend to either supply 10°C.

**Note!** For reasons of general safety, hot water storage temperatures should be maintained at between 60°C - 65°C where serving ablutionary applications. The mixing valve can accept temporary excursions above 85°C without damage, however operation at such elevated temperatures is not recommended.

Minimum maintained pressure: 1 bar.

Minimum maintained pressure (gravity system) : 0.1 bar - flow regulator not fitted.

Maximum maintained pressure: 5.0 bar.

Maximum static pressure: 10.0 bar.

For optimum operation the inlet pressures should be nominally equal.

Maximum Pressure loss Ratio\*: should not exceed 10:1 in favour of either supply during flow.

\* Pressure loss ratio is determined by subtracting the resistance to flow of the outlet pipework and outlet fittings (generally known as the 'back pressure', and measured at the outlet of the mixing valve) from the dynamic pressures of the hot and cold water at the inlets of the mixing valve. This is at its extreme when the mixing valve is being used at its lowest flow rate and when the maximum inequality occurs in the pressure of the hot and cold water supplies.