

RADA 215-T3 C THERMOSTATIC MIXING VALVE



- Buildcert TMV3 Scheme Approved
- WRAS Approved
- Features the unique “Radatherm” service-free cartridge
- Unbeatable temperature control
- Complete with check valves and strainers

**Specify as: Rada 215-t3 c (1.0.440.01.1)**

1/2" thermostatic mixing valve incorporating Radatherm service-free cartridge, check valves and strainers. Housed within swivel elbows, featuring 15 mm compression connectors, which can be converted to 1/2" BSP union if required.

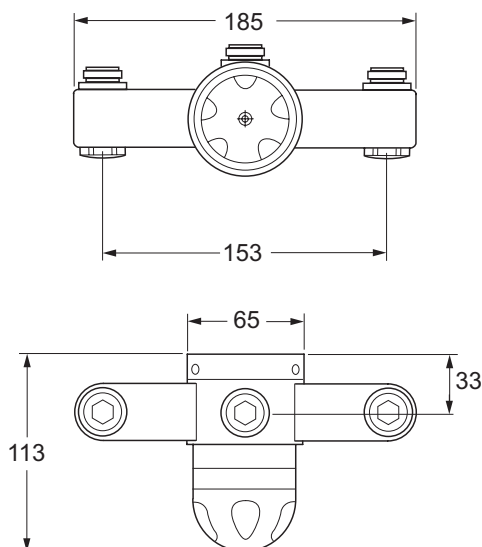
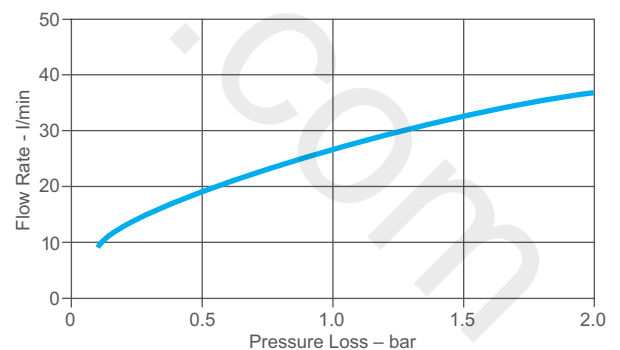
Dimensions (mm)**Flow Diagram**

Kohler Mira Limited
Cromwell Road
Cheltenham
Gloucestershire
GL52 5EP

Specification Enquiries

Tel: 0844 571 1777
Fax: 0844 472 3076
Email: rada_technical@mirashowers.com
www.radacontrols.com

TECHNICAL SPECIFICATION

Installation and Maintenance

Please refer to the appropriate Product Manual.

Connections

Inlet and Outlet: ½" BSP external union or 15 mm compression (nut and olive provided).

Standard connections are **hot** (left), **cold** (right), top outlet.

Approvals

Buildcert TMV3 Thermostatic Mixing Valve Scheme approved:

LP-S - Low Pressure Shower

HP-S - High Pressure Shower

Certificate No: ETC/14/0597.

Complies with the technical requirements of BS7942 for the same designations.

Designed to comply with European Standards EN1111 and EN1287.

WRAS approved (Water Regulations Advisory Scheme).

Designed, manufactured and supported in accordance with accredited

BS EN ISO 9001:2008 Quality Management Systems and

BS EN ISO 14001:2004 Environmental Management Systems

Operation

Rada 215-t3 series mixing valves do not have integral flow control; appropriate provision must be made for this in the outlet pipework.

This can be in the form of basin/bath tap, stopcock, mechanical timed-flow controller or solenoid. The device chosen must be non-concussive in operation.

Materials

Body: DZR brass nickel plated.

Locking Shroud: White engineering plastic.

Temperature Range

Factory pre-set maximum outlet temperature: 43°C.

Minimum temperature differential, blend to either supply: 12°C.

Optimum thermostatic control range: 30 °C - 50 °C.

Minimum cold water temperature: 1°C.

Maximum hot water temperature: 85 °C.

Note! The mixing valve can accept temporary temperature excursions above 85°C without damage, however, operation of the mixing valve at such elevated temperatures is not recommended. For reasons of general safety, hot water storage supply temperatures should ideally be maintained at between 60°C - 65°C where serving ablutionary applications.

Pressures/Flow Rates

Minimum dynamic supply pressure: 0.15 bar.

Maximum dynamic supply pressure: 5 bar.

Minimum flow rate: 3 l/min at mid blend.

Maximum flow rate: 35 l/min at mid blend (which equates to a maximum pressure loss of 1.8 bar).

Maximum pressure loss ratio*: 10:1 (in favour of either supply).

Maximum static pressure: 10 bar.

Note! Both hot and cold pressure should be nominally equal.

* Pressure loss ratio is determined by subtracting the resistance to flow of the outlet pipework and outlet fittings (generally known as 'back pressure', and measured at the outlet of the mixing valve) from the dynamic pressures of the hot and cold water at the inlets of the mixing valve. This is at its extreme when the mixing valve is being used at its lowest flow rate and when the maximum inequality occurs in the pressure of the hot and cold water supplies.

Weight

Product	Gross Weight (Kgs)	Total Packaged Weight (Kgs)
Rada 215-t3 c	2.360	2.555