

RADA THERMOTAP-3 THERMOSTATIC MIXING TAP

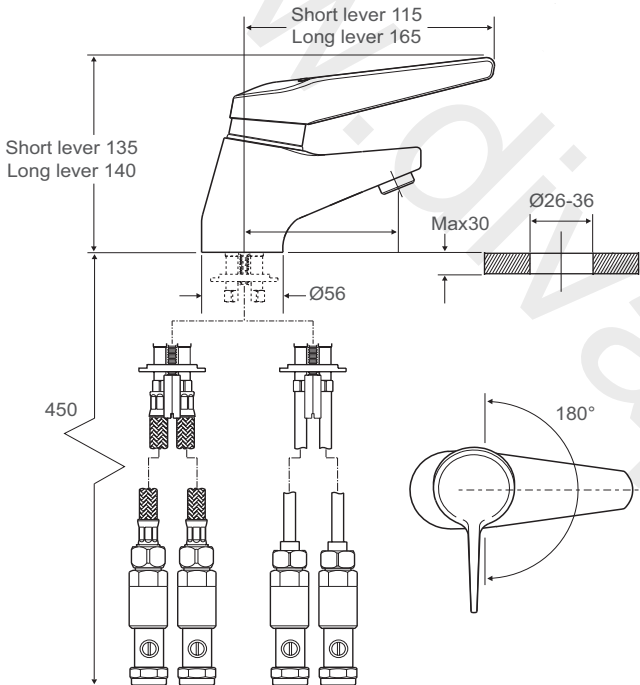

- Buildcert TMV3 Scheme Approved
- WRAS Approved
- Combined thermostatic mixing valve and basin tap
- Simple to use - single lever, sequential control
- Easy to install - fits all single hole basins
- Check valves, strainers and isolators included, with a choice of either flexible or copper tail connections.
- 100 mm and 150 mm lever versions

Dimensions (mm)



**Specify as: Rada Thermotap-3S (1.1555.010)**  
 Basin mounted thermostatic mixing tap with short lever control (100 mm), offering single sequential lever control from cold through to pre-settable maximum temperature. Supplied complete with flexible supply tails, check valves, isolators and strainers.

**Specify as: Rada Thermotap-3L (1.1555.011)**  
 Basin mounted thermostatic mixing tap with long lever control (150 mm), offering single sequential lever control from cold through to pre-settable maximum temperature. Supplied complete with flexible supply tails, check valves, isolators and strainers.

**Specify as: Rada Thermotap-3S Copper (1.1555.061)**  
 Basin mounted thermostatic mixing tap with short lever control (100 mm), offering single sequential lever control from cold through to pre-settable maximum temperature. Supplied complete with copper supply tails, check valves, isolators and strainers.

**Specify as: Rada Thermotap-3L Copper (1.1555.062)**  
 Basin mounted thermostatic mixing tap with long lever control (150 mm), offering single sequential lever control from cold through to pre-settable maximum temperature. Supplied complete with copper supply tails, check valves, isolators and strainers.

Flow Diagram

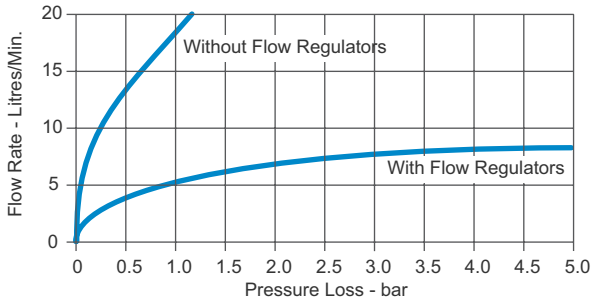

**Kohler Mira Limited**  
 Cromwell Road  
 Cheltenham  
 Gloucestershire  
 GL52 5EP

**Specification Enquiries**  
 Tel: 0844 571 1777  
 Fax: 0844 472 3076  
 Email: rada\_technical@mirashowers.com  
 www.radacontrols.com



TECHNICAL SPECIFICATION

**Installation and Maintenance**

Please refer to the appropriate Product Manual.

**Connections**

Inlets: 15 mm or ½" BSP male and either 10 mm stainless steel flexible hoses or 10 mm chrome plated copper tails (supplied).

The tap hole diameter range is 26 mm - 36 mm.

The tap may be fitted to basins or sinks with ware thickness up to 30 mm.

**Approvals**

Buildcert TMV3 Thermostatic Mixing Valve Scheme approved:  
 HP-WE - High Pressure Washbasin Economy  
 LP-WE - Low Pressure Washbasin Economy  
 Certificate No: ETC/189/1002.  
 Complies with the technical requirements of BS7942 for the same designations.  
 Designed to comply with European Standards EN1111 and EN1287.  
 WRAS listed (Water Regulations Advisory Scheme).  
 Designed, manufactured and supported in accordance with accredited BS EN ISO 9001:2008 Quality Management Systems and BS EN ISO 14001:2004 Environmental Management Systems

**Operation**

The Rada Thermotap-3 has a single lever control for sequential operation from OFF through COLD (minimum), and WARM to HOT (preset maximum). Flow rate is limited to 4 - 6 l/m with flow regulators fitted.

**Materials**

Body: Chrome plated DZR brass.  
 Levers: Chrome plated zinc casting.

**Temperature Range**

The maximum blend temperature is set at 41°C prior to despatch and may be reset during commissioning.  
 Minimum temperature differential blend to either supply: 10°C.  
 Optimum thermostatic control range: 35°C - 45°C.  
 Minimum cold water temperature: 5°C.  
 Maximum hot water temperature: 85°C.

**Note!** The Thermotap-3 can accept temporary temperature excursions above 85°C without damage; however operation at such elevated supply temperatures is not recommended. For reasons of general safety, hot water storage temperatures should ideally be maintained at between 60°C-65°C where serving ablutionary applications.

The full specification performance outlined below is achieved with a blend set between 35°C - 45°C, supplies of 15°C cold and 65°C hot with nominally balanced pressures:

The blended water temperature is maintained within 2°C with a 10°C change in the hot or cold supply.

The blended water temperature is maintained within 2°C when either inlet pressure drops by up to 50%.

The 'Thermostatic' sensor effects a shutdown to seepage within 2 seconds if either supply fails, providing the blended temperature differs from the inlet supply temperatures by at least 10°C.

The tap will maintain control with a pressure in balance of up to 3:1 between hot and cold supplies.

**Pressures**

For optimum performance, supply pressures should be nominally equal.

Recommended Minimum Dynamic Supply Pressure: 0.2 bar.

**Note!** For dynamic supply pressures below 0.4 bar we recommend removal of the flow regulators to allow increased flow.

Recommended flow rate for normal basin applications: 4 - 6 l/min.

Maximum Static Pressure: 10 bar.

Maximum Pressure Loss Ratio\*: should not exceed 10:1, in favour of either supply, during flow.

*\* Pressure loss ratio is determined by subtracting the resistance to flow of the outlet pipework and outlet fittings (generally known as the 'back pressure', and measured at the outlet of the mixing valve) from the dynamic pressures of the hot and cold water at the inlets of the mixing valve. This is at its extreme when the mixing valve is being used at its lowest flow rate and when the maximum inequality occurs in the pressure of the hot and cold water supplies.*

**Weight**

Product	Gross Weight (Kgs)	Total Packaged Weight (Kgs)
Rada Thermotap-3S	2.000	2.300
Rada Thermotap-3L	2.100	2.400

