

Thermotap-3

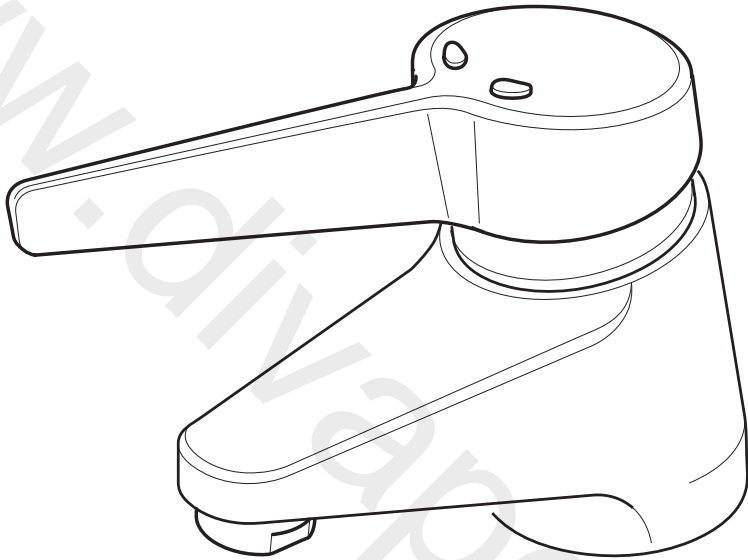

Important! This Manual is the property of the customer and must be retained with the product for maintenance and operational purposes.

Product Manual

rada

CONTENTS

Safety : Warnings	3
Advice	3
Introduction	4
Description	4
Dimensions	5
Specification	6
Pressures/Flow Rates	6
Temperatures	7
Connections	7
Installation	8
General.....	8
Flow Regulator Removal	9
Installation	10
Commissioning	11
Exercising the Thermostat.....	11
Maximum Temperature.....	11
Flow Shut Off Setting	12
Maximum Temperature Setting	13
Operation	14
Fault Diagnosis	15
Maintenance	16
General.....	16
Maintenance Procedures	17
Spare Parts	22
Customer Service	24

If you experience any difficulty with the installation or operation of your new Thermostatic Mixer, please refer to '**Fault Diagnosis**', before contacting Kohler Mira Ltd. Our telephone and fax numbers can be found on the back cover of this guide.

SAFETY : WARNINGS

The function of this thermostatic mixing tap is to deliver water consistently at a safe temperature. This requires that:

1. It is installed, commissioned, operated and maintained in accordance with the recommendations given in this Manual.
2. For Type 3 installations, valves are only to be used for applications covered by their approved designations, refer to the TMV3 Requirements Manual.
3. Periodic attention is given, as necessary, to maintain the product in good functional order. Recommended guidelines are given in section: **'Maintenance'**.
4. Continued use of this product in conditions outside the specification limits given in this Manual can present potential risk to users.

ADVICE

The use of the word 'failsafe' to describe the function of a thermostatic mixing valve is both incorrect and misleading. In keeping with every other mechanism it cannot be considered as being functionally infallible.

Provided that the thermostatic mixing valve is installed, commissioned, operated within the specification limits and maintained according to this Manual, the risk of malfunction, if not eliminated, is considerably reduced.

Malfunction of thermostatic mixing valves is almost always progressive in nature and will be detected by the use of proper temperature checking and maintenance routines.

Certain types of system can result in the thermostatic mixing valve having excessive 'dead-legs' of pipework. Others allow an auxiliary cold water supply to be added to the mixed water from the mixing valve. Such systems can disguise the onset of thermostatic mixing valve malfunction.

Ultimately, the user or attendant must exercise due diligence to make sure that the delivery of warm water is at a stable, safe temperature. This is particularly important in such healthcare procedures as supervised bathing of patients unable to respond immediately to unsafe temperatures.

INTRODUCTION

The Rada Thermotap-3 Lever operated sequential mixing tap is specified to meet the highest standards of safety, comfort and economy as demanded by todays users. The Rada Thermotap-3 is designed, manufactured and supported in accordance with accredited BS EN ISO 9001:1994 Quality Systems.

This Manual covers all Rada Thermotap-3 Lever operated sequential valves manufactured from May 2003.

The suffix '3' indicates that this mixer has been certified for use in UK Healthcare premises as a Type 3 valve under the BUILDCERT TMV3 scheme. For Healthcare installation refer to the TMV3 Requirements Manual.

The approved designations for **Type 3 Valves** are as follows:

Model	Designation Code
Rada Thermotap-3	HP-WE, LP-WE

Guarantee

We guarantee this product against any defect in materials or workmanship for a period of **one** year from the date of purchase. For terms and conditions refer to the back cover.

DESCRIPTION

The Rada Thermotap-3 is a lever operated sequential mixing tap for basins employing a temperature sensor to provide water at safe, constant temperatures for handwashing.

It is suitable for use with single hole basins with hole sizes of between 26 - 36 mm diameter.

Models are available with two configurations of inlet:

- Flexible Braided tails
- Rigid Inlet tails

Both types are supplied complete with two fixing studs, backplate and two fixing nuts providing secure installation. Included are isolators, checkvalves, strainers and flow regulators and they can be fitted with either a short (100 mm) lever or long (150 mm) lever, depending on the application.

DIMENSIONS

All Dimensions and Angles are Approximate.

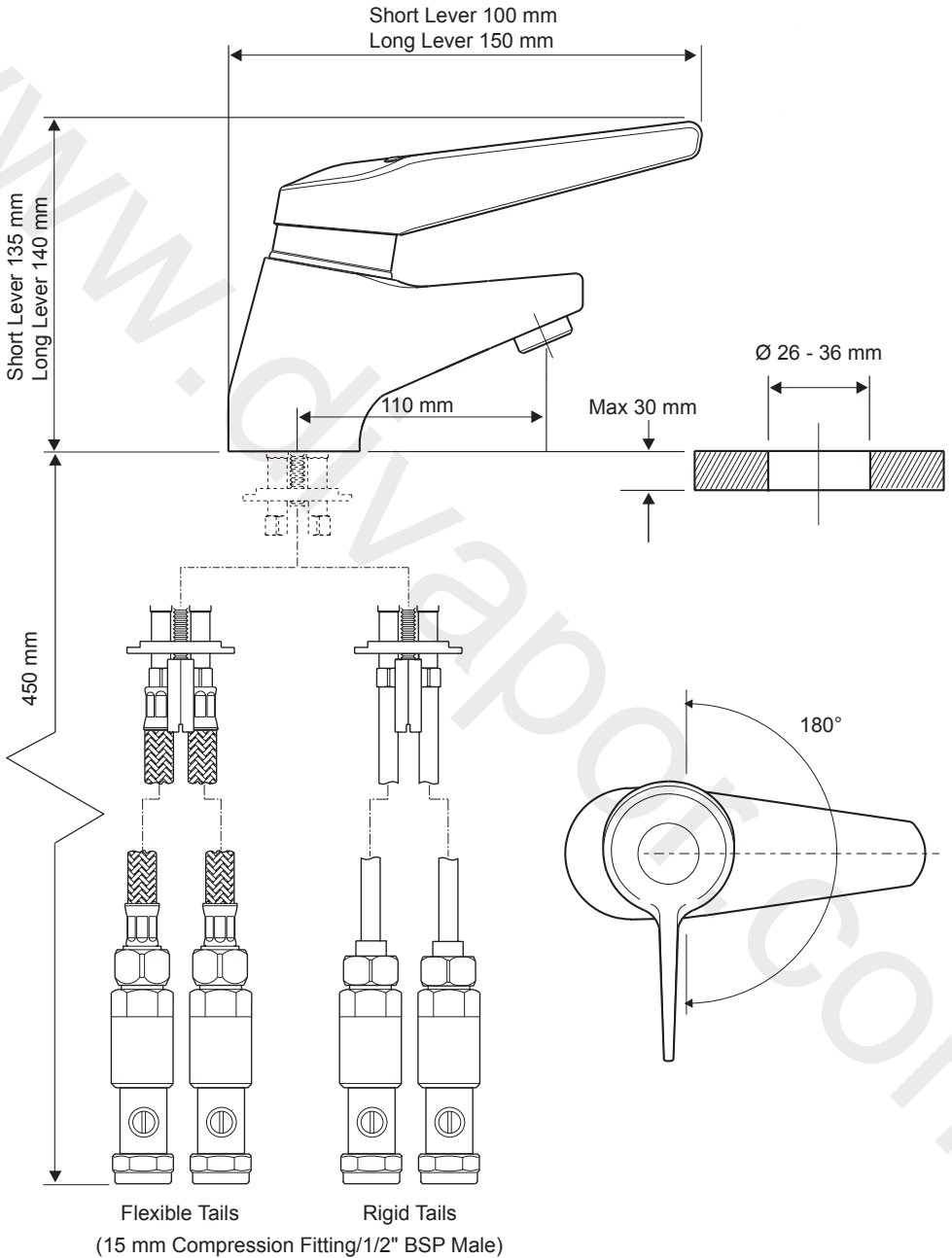

SPECIFICATION

Normal Operating Conditions are considered as:

- inlet dynamic pressures nominally balanced to within 10% of each other during flow
- a differential of approximately 50°C between the hot and cold inlet temperatures, and with differentials of 15 - 35°C between the blend setting and either supply
- daily usage of 1-6 hours
- installation and usage environment not subject to extremes of temperature, unauthorised tampering or wilful abuse.

Other Applications

For information on other specific applications or suitability, refer to Kohler Mira Ltd, or Local Agent.

Disinfection

In applications where system chemical disinfection is practised, chlorine can be used (calculated chlorine concentration of 50 mg/l (ppm) maximum in water, per one hour dwell time, at service interval frequency). Such procedures must be conducted strictly in accordance with the information supplied with the disinfectant and with all relevant Guidelines/Approved Codes of Practice. If in any doubt as to the suitability of chemical solutions, refer to Kohler Mira Ltd, or Local Agent.

Operating Parameters

For Type 3 valves the supply conditions specified in the TMV3 Requirements Manual take precedence over the operating parameters which follow.

Pressures/Flow Rates

For optimum performance, dynamic supply pressures should be nominally equal.

Recommended Flow Rate: 4 - 8 litres/minute (with flow regulators fitted).

Recommended Minimum Dynamic Supply Pressure: 0.1 bar (0.2 bar healthcare).

Note! For dynamic supply pressures below **0.4 bar** we recommend removal of the flow regulators to allow increased flow.

Maximum Static Supply Pressure:	Flexible Inlet Tails	6 Bar.
	Rigid Inlet Tails	10 Bar

Maximum Inlet Pressure Differential: should not exceed **3:1**, in favour of either supply, during flow.

Flow Rate v Supply Pressure.

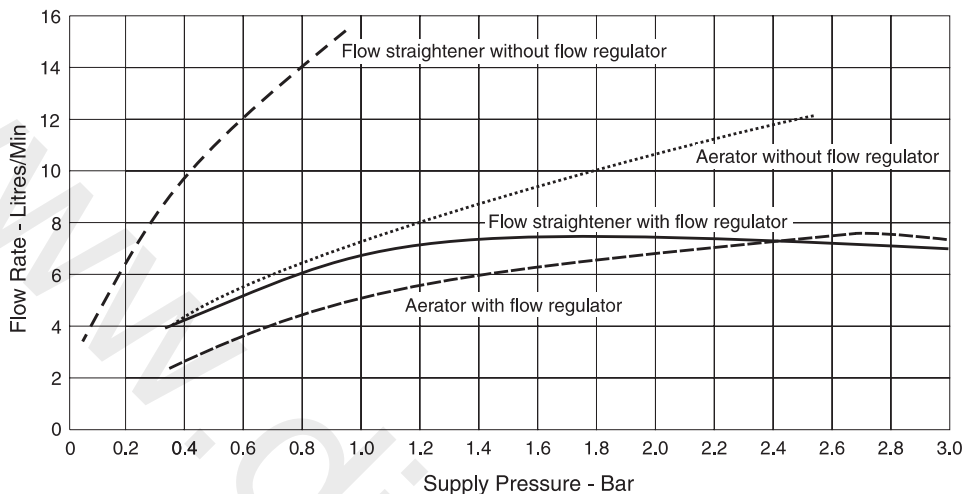

Temperatures

Optimum performance is obtained when **temperature differentials** of **20°C** or more exist between blend and either supply. Blend control accuracy will begin to diminish at temperature differentials below **10°C**.

Blend Temperature Range: between ambient cold and approximately 45°C, according to hot water supply temperature.

Recommended Minimum Cold Water Supply Temperature: 5°C.

Recommended Maximum Hot Water Supply Temperature: 65°C.

Note! The Thermotap-3 can accept temporary temperature excursions up to 85°C without damage, however operation at such elevated supply temperatures is not recommended. For reasons of general safety, hot water storage temperatures should ideally be maintained at between 60 - 65°C where serving ablutionary applications.

Connections

Hot and cold inlet supply connections are via 15 mm compression fittings or 1/2" BSP male provided on the inlets to the isolating valves. Where flexible inlet tails are chosen, the red hose is connected to the threaded hole on the tap marked with a RED label adjacent to the hole (nearest to spout).

INSTALLATION

General

Installation must be carried out in accordance with these instructions and must be conducted by designated, qualified and competent personnel.

Before commencing, make sure that the installation conditions comply with the information given in section: '**Specifications**'. For Type 3 valves see also Installation conditions in The TMV3 Requirements Manual.

The installation must comply with the “Water Supply (Water Fittings) Regulations or Scottish Byelaws” or any particular regulations and practices, specified by the local water company or water undertakers.

1. Care must be taken during installation to prevent any risk of injury or damage.
2. The hole in the basin must be a minimum of 26 mm up to a maximum of 36 mm diameter, with a basin thickness of 30 mm maximum.
3. The Thermotap-3 should be positioned for easy access during use and maintenance. All routine maintenance procedures can be conducted with the Thermotap-3 body in place.
4. Inlet pressure tapplings which allow measurement of the inlet pressures to the mixing valve under operating conditions are particularly recommended for healthcare applications with Type 3 valves.
5. Pipework dead-legs should be kept to a minimum. The overall length from the hot water circuit to the discharge point should not exceed 5 m.
6. Supply pipework layout should be arranged to minimise the effect of hydraulic restriction or other outlet usage upon the dynamic pressures at the Thermotap-3 inlets. Recommended minimum supply line pipe diameter is 8 mm.
7. For **Dynamic Supply Pressures** below **0.4 bar** we recommend removal of the flow regulators to allow increased flow.
8. **To eliminate pipe debris it is essential that supply pipes are thoroughly flushed through before connection to the Thermotap-3.**

Flow Regulator Removal

Note! This procedure is only necessary when the dynamic supply pressure is below 0.4 bar.

1. Isolate the hot and cold supplies with the isolating valves.
2. Disconnect the flexible hoses or rigid inlet tails as applicable, by unscrewing the union nuts. Retain the sealing washer or replace if necessary.
3. Unscrew the checkvalve housing from the isolating valve. Remove the flow regulator using long nose pliers or a small screwdriver.
4. Reassembly is reverse of the above, ensure the strainer is clean before replacing.

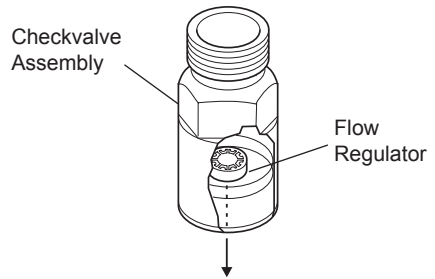

Flow Regulator Removal

Installation

1. Screw the fixing studs fully into the Thermotap-3 body.
2. Place the 'O' seal in the groove in the base of the Thermotap-3 body.
3. Place either rigid or flexible inlet tail through one of the larger holes in the backplate, orientate the backplate to suit the hole size in the basin.
5. Working underneath the basin offer the inlet tail up through the hole in the basin.
4. Screw inlet tail (if using flexible type, red coloured hose) into the Thermotap-3, hole marked with a RED label (nearest the spout) and tighten. Position tap on basin.
5. Pull the backplate over the fixing studs.
6. Working underneath the basin, locate other inlet tail (blue coloured flexible hose) through backplate then screw and tighten into remaining hole in tap, spread tails apart slightly if necessary to assist in fitting.
7. Make sure that the Thermotap-3 is correctly positioned and screw the fixing nuts onto the fixing studs. Tighten the fixing nuts until the tap is secure. **DO NOT OVERTIGHTEN.**
8. Connect the isolating valves to the supply pipework. Fit the strainer into the isolating valve and screw in the checkvalve housing. Use a suitable spanner to tighten the checkvalve assemblies.
9. Locate the sealing washers inside the nuts on the inlet tails and screw onto the checkvalve assemblies. Please ensure that the inlet tail (red coloured flexible hose) previously connected to hole marked with a RED label is connected to hot supply. Use a suitable spanner to tighten the union nuts.
10. Restore the water supplies and check all connections are watertight. Refer to section '**Commissioning**'.

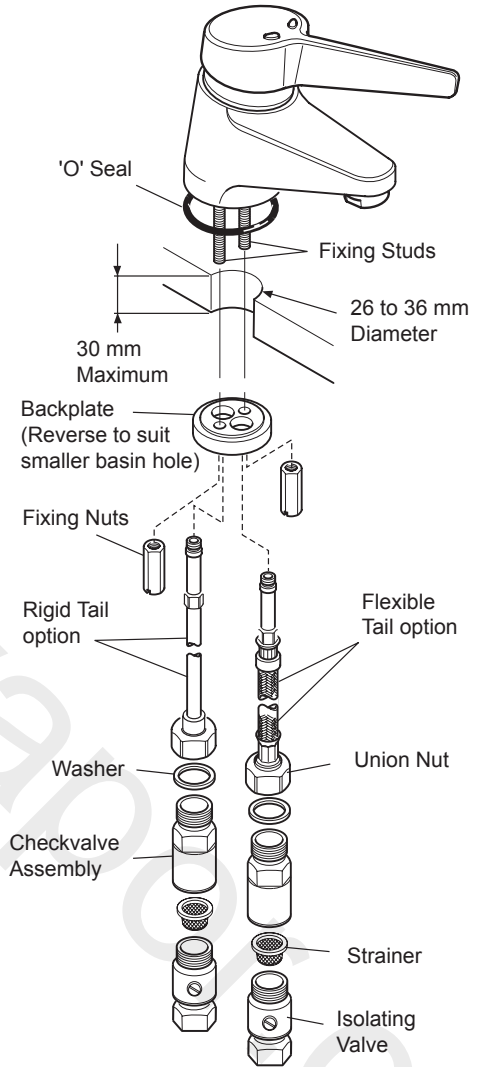

COMMISSIONING

Commissioning must be carried out in accordance with these instructions, and must be conducted by designated, qualified and competent personnel.

Exercising the Thermostat

Thermostatic mixing valves are inclined to lose their responsiveness if not used. Valves which have been in storage, installed but not commissioned, or simply not used for some time should be exercised before setting the maximum temperature or carrying out any tests.

A simple way to provide this exercise is:

1. Make sure that hot and cold water is available at the valve inlets, and the outlet is open.
2. Move the temperature control rapidly from cold to hot and hot back to cold several times, pausing at each extreme.

Maximum Temperature

The maximum blend temperature obtainable by the user should be limited, to prevent accidental selection of a temperature that is too hot.

Note! For Type 3 valves in healthcare installations the maximum blend temperature is determined by the application, refer to the TMV3 Requirements Manual.

The Rada Thermotap-3 is fully performance tested, and the maximum temperature is preset to approximately 41°C under ideal installation conditions at the factory.

Site conditions and personal preference may dictate that the maximum temperature has to be reset following installation.

This product includes an **adjustable stop ring** which limits the rotation of the lever control. The stop ring and lever will need to be assembled correctly to make sure that the flow shuts off and the maximum temperature limit is set.

If the tap has been dismantled for servicing of the internal parts, or the lever removed for any reason, refer to sections: '**Flow Shut Off Setting**' and '**Maximum Temperature Setting**'.

Flow Shut Off Setting

1. Fully open the inlet isolation valves.
2. Remove the lever using the 2.5 mm A/F hexagonal wrench, and remove the stop ring.
3. Refit the lever to the spindle (position not important) and open the tap.
4. Turn the lever to the off position so the flow **just stops**, then rotate a further 10 - 20 degrees, to make sure of a tight shut off.
5. Remove the lever and refit the stop ring with the arrow aligned with the tap spout (refer to illustration).
6. Fit the lever to the spindle in the **OFF** position (parallel to the wall) and make sure that the lever engages with the stop, i.e. cannot be turned clockwise (refer to illustration).

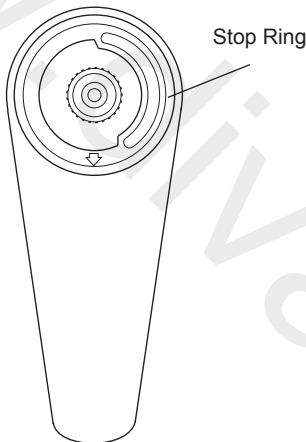

Stop Ring Alignment

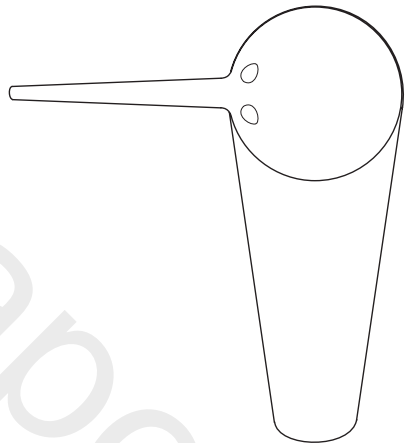

Lever in Stop Position

Maximum Temperature Setting

Make sure that an adequate supply of **hot** water is available at the hot inlet of the Thermotap-3.

The minimum temperature of the hot water must be at least 10°C above the desired blend, however during resetting this should be close to the typical storage maximum to offset the possibility of any blend shift due to fluctuating supply temperatures.

Make sure that both inlet isolating valves are fully open.

Temperatures should always be measured using a thermometer with proven accuracy.

1. Turn the lever 1/2 turn anticlockwise until it engages the maximum temperature stop (Refer to illustration).
2. Let the water run until the temperature stabilizes.
3. Check the water temperature, which is factory preset to 41°C.
4. If the maximum temperature requires adjustment, remove the lever taking care not to turn the spindle.
5. Insert the 2.5 mm A/F hexagonal wrench (supplied) to engage the grub screw in the centre of the head assembly (Refer to illustration).
6. Rotate the grub screw as necessary until the required maximum blend temperature is achieved. Rotate the grub screw **anticlockwise to increase** the temperature or **clockwise to decrease** the temperature.
7. Refit the lever in the **same position** and check the operation i.e. full shut off is achieved and maximum temperature is correct.
8. Move the lever to the off position.
9. Use the 2.5 mm A/F hexagonal wrench to secure the lever to the spindle.
10. Fit blanking plug to lever.

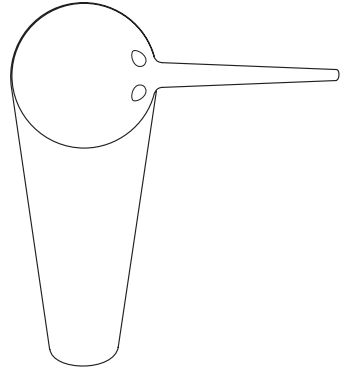

Lever at Maximum Temperature Position

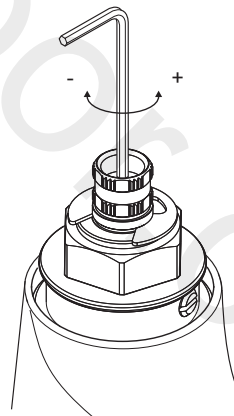

Maximum Blend Temperature Setting

OPERATION

The Rada Thermotap-3 has a single lever that provides sequential operation from OFF through COLD and WARM to a preset maximum blend temperature. The maximum temperature is preset to approximately 41°C under ideal installation conditions at the factory. To change this setting refer to the information given in section: **Commissioning**.

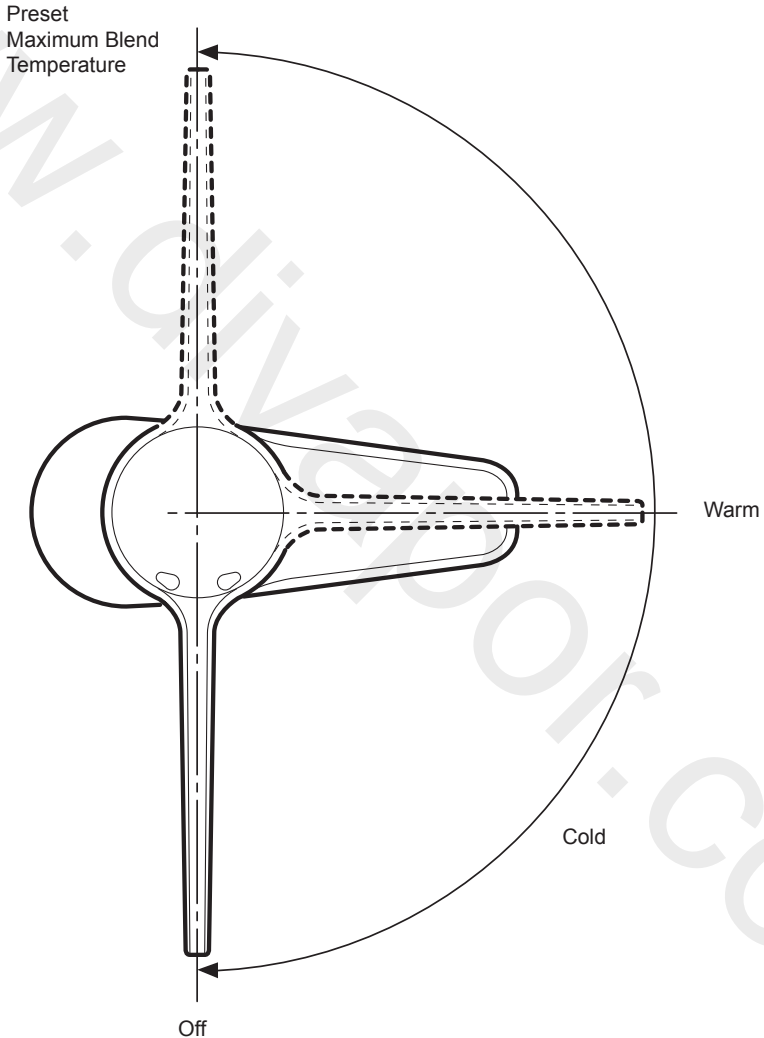

Principle of Operation

FAULT DIAGNOSIS

Symptom	Cause/Rectification
1. Only hot or cold water from outlet.	<ul style="list-style-type: none"> a. Inlet supplies reversed (hot supply to cold inlet). Check. b. No hot water reaching Thermostat-3. Check. c. Check strainers and inlet/outlet fittings for blockage. d. Refer symptom 5. below. e. Installation conditions continuously outside operating parameters: refer to section: 'Specifications', and 2.e. below.
2. Fluctuating or reduced flow rate.	<p>Normal function of thermostatic control when operating conditions are unsatisfactory;</p> <ul style="list-style-type: none"> a. Check strainers and inlet/outlet fittings for flow restriction. b. Make sure that minimum flow rate is sufficient for supply conditions, refer to symptom 9.b. below. c. Make sure that dynamic inlet pressures are nominally balanced and sufficient. d. Make sure that inlet temperature differentials are sufficient. e. (Subsequent to rectification of supply conditions) Check thermostatic performance; renew shuttle/thermostat assembly if necessary.
3. No flow from outlet.	<ul style="list-style-type: none"> a. Check strainers and inlet/outlet fittings for blockage. b. Hot or cold supply failure; thermostat holding correct shutdown function: rectify, and refer to symptom 2.e. above. c. Circlip disengaged from head assembly, Check.
4. Blend temperature drift.	<p>Indicates operating conditions changed.</p> <ul style="list-style-type: none"> a. Refer to symptom 2. above. b. Hot supply temperature fluctuation. c. Supply pressure fluctuation. d. Seal(s) damage or wear. Renew internal 'O' seals.
5. Hot water in cold supply or vice versa.	<p>Indicates checkvalves require maintenance, refer to MAINTENANCE.</p>

Symptom	Cause/Rectification
6. Maximum blend temperature setting too hot or too cool.	<p>a. Indicates incorrect maximum temperature setting; refer to COMMISSIONING.</p> <p>b. As symptom 4. above.</p> <p>c. As symptom 5. above.</p>
7. Waterleaking from body.	<p>a. Seal(s) worn or damaged. Obtain service pack (936 23), and renew all seals.</p> <p>b. If leak persists from around spindle renew head assembly.</p>
8. Flow does not cease fully when lever is in off position.	<p>a. Check flow shut off setting - see Commissioning Section.</p> <p>b. Hot seat damaged; obtain service pack and renew. Cold seat 'O' seal can not be renewed; replace Head Assembly.</p> <p>c. Shuttle/thermostat assembly damaged; renew.</p> <p>d. Head assembly worn; renew seals or head assembly.</p>
9. Flow rate too high or too low.	<p>a. Too low, Refer symptom 2.a-e. above.</p> <p>b. Too low, Supply pressure low, make sure flow regulators are not fitted.</p> <p>c. Too high, Supply pressure high, make sure regulators are fitted.</p> <p>d. Hot & cold flows differ, Refer to symptom 2.a-e. above.</p>

MAINTENANCE

General

- The maintenance of this product must be carried out in accordance with instructions given in this manual, and must be conducted by designated, qualified and competent personnel.
- Rada products are precision-engineered and should give continued superior and safe performance, provided:
 - They are installed, commissioned, operated and maintained in accordance with the recommendations stated in this product manual.
 - Periodic attention is given as necessary to maintain the product in good functional order, refer to section: **'Planned Maintenance'**.

Service Contracts

To ensure your Rada/Mira products function correctly and give continued safe performance Service Contracts can be undertaken (subject to site survey).

All Service Contract work is carried out by fully trained Rada/Mira Service Engineers who carry a comprehensive range of genuine spare parts. For details on arranging a Service Contract please contact Aftersales/Service.

Lubricants

Important! If you need to lubricate the seals, use only a small amount of silicone-only based lubricants on this product. Do not use oil-based or other lubricant types as these may cause rapid deterioration of seals, (grease sachet is included in 'Service Pack').

Planned Maintenance

Important! For Type 3 Valves use the In-Service Tests given in the TMV3 Requirements Manual. In the absence of any other instruction or guidance on the means of determining the appropriate frequency of in-service testing, the procedure contained within this guide (taken from Annex F of D08) should be used.

For other commercial installations it is recommended that the correct blend setting is checked every 6 months and that the In-Service Test procedure is followed every 12 months.

Maintenance Procedures

The Thermotap-3 is designed for minimal maintenance under conditions of normal use. External surfaces may be wiped clean with a soft cloth, and if necessary, a mild washing-up type detergent or soap solution can be used.

Warning: many household and industrial cleaning products contain mild abrasives and chemical concentrates, and should **not** be used on polished, chromed or plastic surfaces.

Should an internal malfunction occur then this will probably require component renewal. Components are precision-made, so care must be taken while servicing to avoid damage.

When ordering spare parts, please state product type, i.e. Rada Thermotap-3 and identify part name and number. A service pack is available, containing all the seals and strainer screens that may be necessary for renewal during maintenance or servicing. Refer to the section: '**Spare Parts**'.

If for any reason the tap cannot be fully shut off, it may be necessary to readjust the lever shut off position. Refer to **Lever Shut Off Position**.

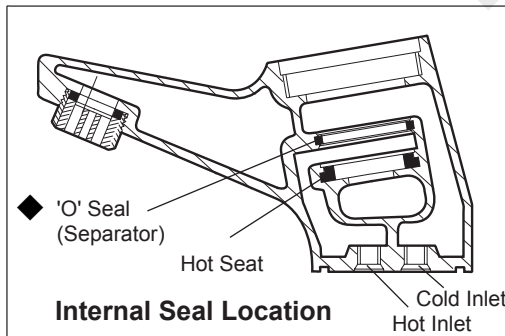
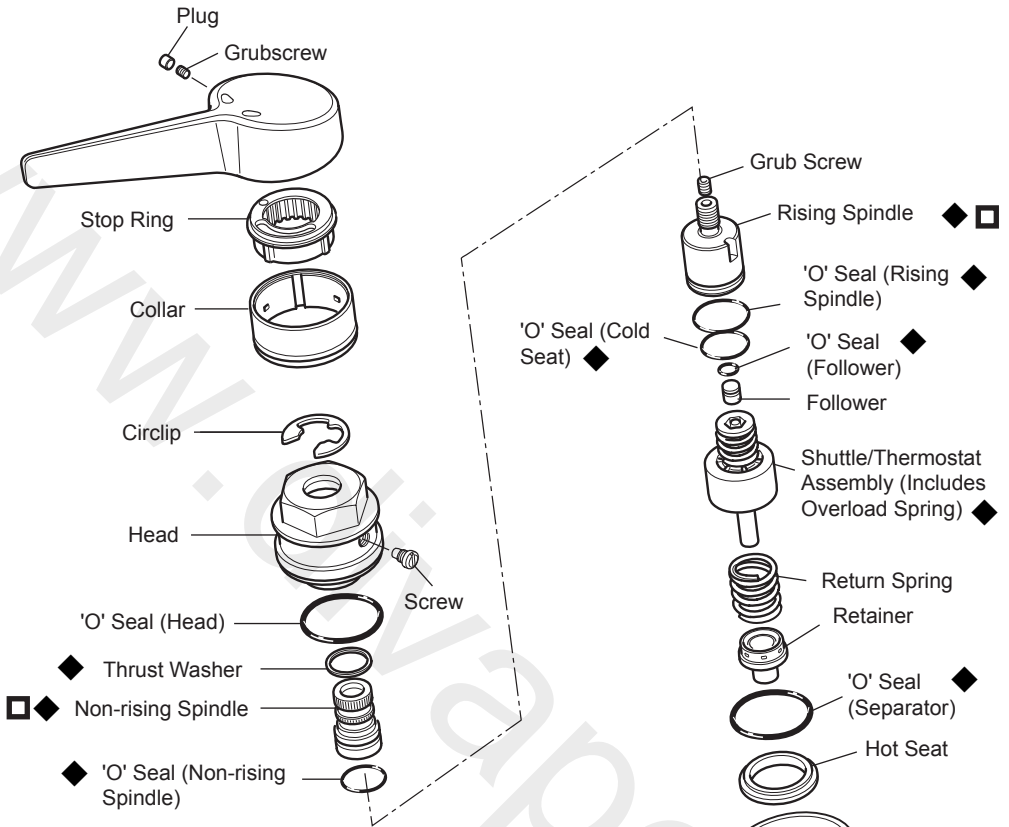

- ◆ Applied recommended lubricants for **dynamic** seals/components - Refer to **Lubricants**
- **Note!** Do not clean grease from spindle threads. This is a special lubricant designed to work for the life of the product.

Internal Mechanism - Disassembly/Assembly

Lever Shut Off Position

1. Turn the lever fully to the off position. Remove plug and slacken the grub screw which secures the lever, and remove the lever.
2. Refit the lever to the spindle one serration anticlockwise (approx 10 degrees).
3. Turn the lever fully clockwise to the stop (lever should be parallel with the wall) and ensure that tight shut off is achieved.
4. If tap continues to drip repeat the above procedure, adjusting the lever one further serration.
5. After adjusting the lever position it may be necessary to adjust the maximum temperature stop. Refer to section: '**Commissioning**'.
6. If tap continues to drip, replace the internal seals. Refer to **Maintenance Procedure - Internal Mechanism**.

Maintenance Procedure - Internal Mechanism

Removal

1. Isolate the hot and cold supplies, and move the lever to its mid position to release any pressure.
2. Remove the plug in the side of the lever and use a 2.5 mm A/F hexagonal wrench to loosen the grub screw. Remove the lever.
3. Pull the collar and stop ring off the head assembly.
4. Use a suitable spanner to remove the head assembly.
5. Remove the circlip and screw from the head assembly.
6. Push the rising and non-rising spindles out of the head.
7. Insert the 2.5 mm A/F hexagonal wrench into the grub screw in the centre of the rising spindle.
8. Rotate the grub screw clockwise until it pushes the follower out of the rising spindle. Remove the thrust washer.
9. DO NOT unscrew the rising and non-rising spindles from each other, or remove the 'black' grease as these are 'greased for life' during manufacture.
10. Carefully remove the 'O' seals from the head, the non-rising spindle, the rising spindle and the follower. **Do not** remove the 'O' seal in the bottom face of the rising spindle at this stage (refer to paragraph 15). This 'O' seal forms the cold seat for the Thermotap-3 and the groove is swaged to hold it in position.
11. Withdraw the shuttle/thermostat assembly, complete with return spring, from the Thermotap-3 body. Do not disassemble the shuttle/thermostat assembly.
12. Carefully remove the retainer, the separator 'O' seal and the hot seat from the Thermotap-3 body. Take care not to damage the seal grooves.

Cleaning/Renewal of Parts

13. Internal parts can be cleaned using a mild proprietary inhibited scale solvent, e.g. domestic kettle descaler. After descaling, always rinse parts thoroughly in clean water before refitting.

Note! Make sure that components are cleaned carefully and not damaged in any way. Do not use any abrasive material on component surfaces.

14. Inspect the shuttle/thermostat assembly for signs of damage or leakage; renew the assembly if in any doubt of the condition. Check the overload spring in the shuttle/thermostat assembly for free movement by compressing it several times; renew the assembly if the components are sticking.

Note! The shuttle/thermostat cannot be tested individually, its condition can only be assessed as part of the performance check; refer to section: '**Commissioning**'.

15. Examine all seals (particularly the separator 'O' seal, the cold seat 'O' seal and the hot seat) for signs of wear or deformation.
16. Install the new seals as necessary, taking care not to damage the seal grooves. A **service pack** is available, containing all the seals and strainer screens that may be necessary for renewal during maintenance or servicing. Refer to section: '**Spare Parts**'.
17. Lightly coat all seals with a **silicone-only based lubricant** (included in the Service Pack) to assist re-assembly. Refer to section: '**Maintenance, Lubricants**'.

Re-assembly

18. Use the 2.5 mm A/F hexagonal wrench to screw the grub screw into the rising spindle.
19. Insert the follower, complete with 'O' seal, into the rising spindle. The larger diameter seal-end must be inserted first.
20. Place the thrust washer on the non-rising spindle.
21. Align the slot in the rising spindle with the screw hole in the head, and push the spindles, complete with 'O' seals, fully into the head.
22. Check the alignment and install the screw. Tighten the screw.
23. Fit the circlip.
24. Make sure that the separator 'O' seal (blue) and the hot seat are fitted to the Thermostat-3 body correctly, and install the retainer. Grease the 'O' seal.
25. Locate the spring on the retainer, and install the shuttle/thermostat assembly.
26. Carefully screw the head assembly, complete with 'O' seal into the Thermostat-3 body. Use a suitable spanner to tighten the head assembly fully.
27. Fit the collar and stop ring with the arrow aligned with the spout.
28. Refer to section: '**Commissioning**' for resetting the flow shut-off and maximum temperature.

Maintenance Procedure - Checkvalves & Strainers

Refer to illustrations in section: '**Installation**'.

Hot water entering the cold supply, or vice versa, indicates that immediate attention is required. This is performed by removing and cleaning, or renewing the checkvalve assemblies as necessary.

Blockage of the strainer screens can lead to poor flow performance and reduced temperature control. It is essential that the strainer screens are cleaned or, if necessary renewed, as part of the six-monthly maintenance operations.

Removal

1. Isolate the hot and cold supplies, and move the lever to its mid position to release any pressure.
2. Use a suitable spanner to remove the flexible or rigid inlet tails (as applicable) from the checkvalve assemblies. Retain the sealing washers.
3. Use a suitable spanner to unscrew the checkvalve assemblies from the isolating valves. The strainers can then be removed.

Cleaning/Renewal of Parts

4. Flush the checkvalves with a jet of clean water to remove any debris. The checkvalves are not serviceable items, and if flushing does not rectify the problem the checkvalve assemblies must be replaced.
5. Make sure that the strainers are clean and the integral seal is not damaged. Replace as necessary.

Re-assembly

6. Installation of the checkvalve assemblies is a reversal of the removal procedure. If new checkvalve assemblies are fitted, remove flow regulators if not previously installed.
7. Restore the water supplies and check for leaks.

SPARE PARTS

066.66	Flow Regulator
455.01	Short Lever Assembly
455.02	Long Lever Assembly
455.04	Flexible Tail - Cold
455.05	Flexible Tail - Hot
455.07	Aerator
455.10	Checkvalve Assembly (single)
916.59	Flow Straightener
925.72	Shuttle/Thermostat Assembly
928.49	Head Assembly
936.13	Fixing Kit
936.23	Service Pack (components identified *)
1555.063	Rigid Tails (pair)
1555.072	Inlet Strainer x 6
1555.074	Stop Ring and Collar

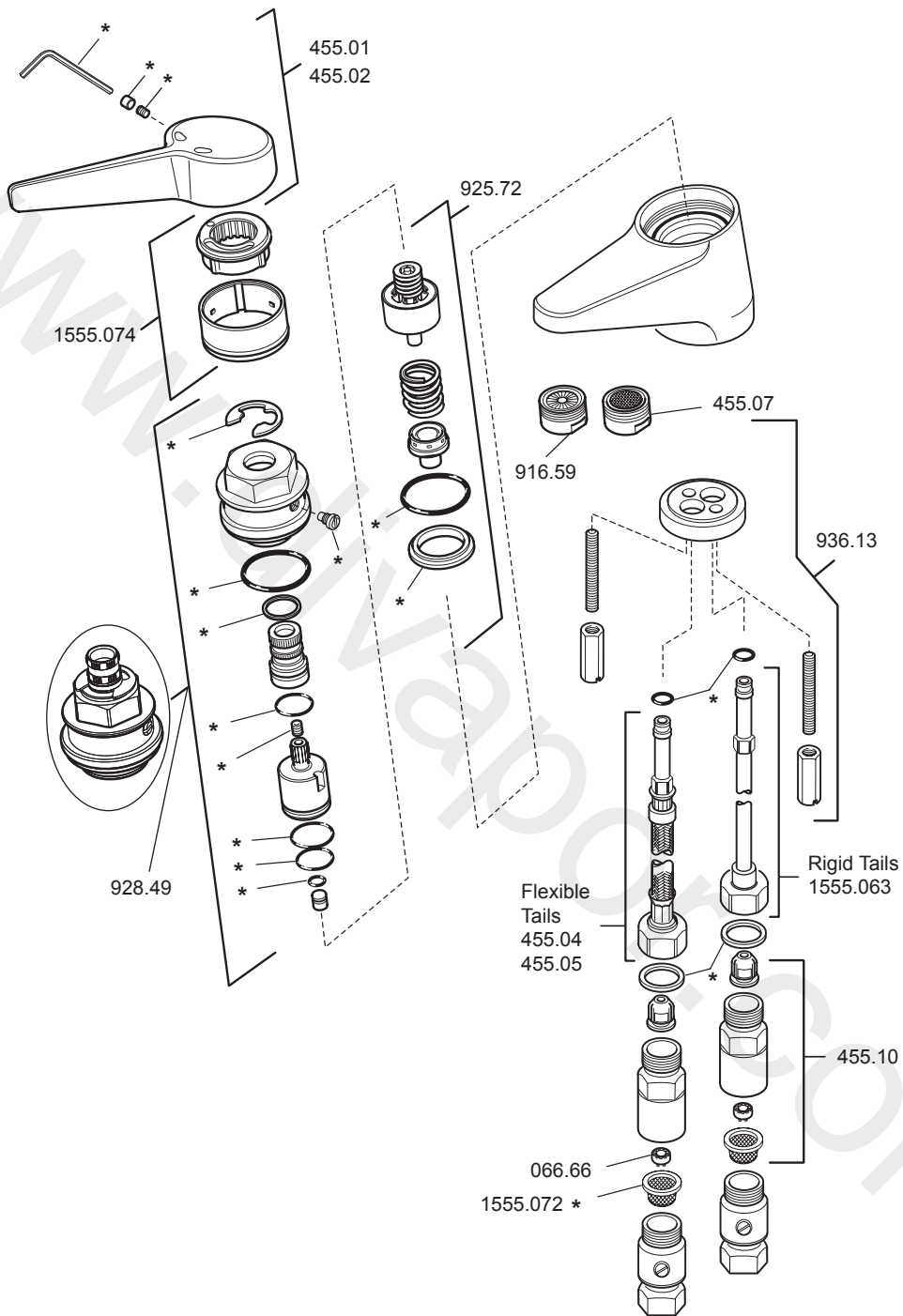

CUSTOMER SERVICE

Guarantee

Your product has the benefit of our manufacture's guarantee which starts from date of purchase. Within the guarantee period we will resolve defects in materials or workmanship, free of charge, by repairing or replacing parts or product as we may choose.

This guarantee is in addition to your statutory rights and is subject to the following conditions:

- The product must be installed and maintained in accordance with the instructions given in this user guide.
- Servicing must only be undertaken by us or our appointed representative. **Note!** If a service visit is required the product must be fully installed and connected to services.
- Repair under this guarantee does not extend the original expiry date. The guarantee on any replacement parts or product ends at the original expiry date.
- For shower fittings or consumable items we reserve the right to supply replacement parts only.

The guarantee does not cover:

- Call out charges for non product faults (such as damage or performance issues arising from incorrect installation, improper use, inappropriate cleaning, lack of maintenance, build up of limescale, frost damage, chemical attack, corrosion, system debris or blocked filters) or where no fault has been found with the product.
- Water or electrical supply, waste and isolation issues.
- Compensation for loss of use of the product or consequential or indirect loss of any kind.
- Damage or defects caused if the product is repaired or modified by persons not authorised by us or our appointed representative.
- Routine maintenance or replacement parts to comply with the requirements of the TMV2 or TMV3 healthcare schemes
- Accidental or wilful damage.
- Products purchased ex-showroom display.

What to do if something goes wrong

If your product does not work correctly refer to this manual for fault diagnosis and check that it is installed and commissioned in accordance with our instructions. If this does not resolve the issue, contact us for help and advice.



Technical Helpdesk Service

Contact our Customer Services Team for product advice, to purchase spare parts or accessories or to set up service visit. You can contact us via phone or e-mail - contact details below. Please provide your model name, power rating (if applicable) and date of purchase.



Rada Website (www.radacontrols.com)

From our website you can view our full product catalogue or download a brochure.



Spares and Accessories

We hold the largest stocks of genuine Rada spares and accessories.



Service/Repairs

No one knows our products better than our nationwide team of Service Technicians. We can carry out service or repair work to your product both during and after the guarantee period. You have the assurance of a fully trained Technician, genuine Rada spare parts and a 12 month guarantee on any chargeable work done.

Service Contracts

Regular servicing ensures your product continues to operate at the peak of performance. We offer annual or bi-annual servicing carried out by our fully trained technicians subject to site survey

To Contact Us - UK Customer Service & Specification Enquiries



0844 571 1777

Calls cost 7p per minute plus your phone company's access charge



Fax: 0844 472 3076



Email – Visit

rada_technical@mirashowers.com



By Post: Rada Controls, Cromwell Road, Cheltenham, Gloucestershire GL52 5EP

To Contact Us: Eire Only



01 531 9337



E-mail:

CustomerServiceEire@mirashowers.com

Rada is a registered trade mark of Kohler Mira Limited.

The company reserves the right to alter product specifications without notice.



rada