





-  100184779\_N199999226
-  100190646\_N199999149
-  100190680\_N199999144



100190368\_N299998777

**noken**  
PORCELANOSA BATHROOMS

Carretera CV-20 km.2 · 12540 Vila-real · Castellón · Spain  
Tel: +34 964 50 64 50 - Fax: +34 964 50 67 93  
e-mail: [noken@noken.com](mailto:noken@noken.com) · [www.noken.com](http://www.noken.com)

**TONO**



Lea atentamente estas instrucciones antes de comenzar la instalación.

- Compruebe el producto por si faltasen piezas o estuviesen dañadas.
- Cualquier alteración que se realice al sanitario invalidaría la garantía.
- Le recomendamos la instalación por parte de personal cualificado.
- En nuevas construcciones se deben llenar los sifones de inodoros, lavabos y bidets de agua para evitar que la grifería y los asientos se oxiden o amarilleen por el efecto de la subida de gases corrosivos. Se recomienda que el espacio esté muy aireado.
- Purgar las tuberías antes de la instalación.
- Gracias a un cuidado periódico se puede evitar la formación de restos calcáreos.
- Residuos de productos de aseo y limpieza pueden dañar las piezas metálicas, cromadas y/o de vidrio de los sanitarios, como bisagras, embellecedores, pulsadores, etc...
- Las griferías no deben instalarse en ambientes donde la temperatura pueda descender de 0°C, dado que la congelación de las tuberías podría dañar la grifería.

- Es responsabilidad del instalador comprobar que la temperatura máxima de funcionamiento nunca será superior a 48°C ya que las condiciones en la obra pueden ser diferentes a las condiciones de fábrica bajo las que se ha regulado la grifería. En caso de ser necesario, ajustar la temperatura máxima de funcionamiento conforme se indica en las instrucciones de montaje

**Atención:** Recuérdese que es obligatorio verificar la correcta instalación de la grifería y la inexistencia de fugas antes de recubrir el muro ya que algunas de las partes encastradas ya no serán accesibles. Noken Design declina toda responsabilidad en caso de incumplimiento de esta premisa.

Please read these instructions carefully before starting installation and retain for future reference. Please leave these instructions with the end user.

- Remove all packaging and check the product for missing parts and damages before starting the installation.
- Any alterations made to this product and its fittings may infringe the water regulations and will invalidate the guarantee.
- We strongly recommend the use of a qualified and registered plumber.
- In new buildings it is recommended to water fill the traps to ensure toxic gases do not corrode the surface of the taps and toilet seats. It is recommended that the room is well ventilated.
- Thoroughly flush through all pipe work prior to the installation of terminal appliances, e.g. Shower heads, taps, inlet valves etc.
- Periodic cleaning and maintenance should be used to avoid the build up of damaging lime scale deposits.
- Bathroom harsh cleaning agent residuals may damage components made of metal, glass and/or chromed parts such as, seat hinges, trim plates, push buttons, etc...
- Faucets do not have to be installed in environments where temperature may drop below 0°C as frozen pipes may damage faucets.

- Installer has the responsibility to check that maximum working temperature is not going to be higher than 48°C as plumbing conditions may differ from factory conditions under the thermostat is regulated. If it is necessary, adjust maximum working temperature as it is shown in the installation letter.

**Attention:** Do not forget to check the existence of any sort of leaks while the inner pieces are accessible, just before installing the tap and wallcovering or tiling, as some concealed pieces will not be reachable anymore. Noken Design refuses their responsibility in case of omitting this premise.

Lire attentivement cette notice avant de commencer l'installation

- Vérifier si certaines pièces sont manquantes ou abîmées.
- Toute altération qui sera effectuée à la sanitaire rendra invalide la garantie.
- Nous recommandons fortement l'installation du produit par du personnel qualifié.
- Dans le cas de constructions neuves, il faut mettre en eau les WC, lavabos et bidets pour éviter que la robinetterie et les abattants ne s'oxydent ou ne jaunissent à cause de gaz corrosif. Nous recommandons de laisser un espace très aéré.
- Purger les tuyauteries avant l'installation.
- Grâce à un entretien régulier, on peut éviter la formation de calcaire.
- Produits résiduels des toilettes et nettoyage peuvent abîmer les pièces métalliques, en verre et/ou chromée des sanitaires, comme les charnières, enjoliveurs, boutons poussoirs, etc...
- Les robinetteries ne doivent pas être installées à des températures inférieures à 0°C, étant donné que la congélation des tuyauteries peut abîmer la robinetterie.
- L'installateur est responsable de vérifier à ce que la température maximale ne soit jamais supérieure à 48°C en effet les conditions du chantier peuvent être différentes aux conditions d'usine auxquelles la robinetterie a été réglée. Si nécessaire, régler la température maximale de fonctionnement comme indiqué sur les instructions de montage.

**Attention :** Ne pas oublier de vérifier la bonne installation de la robinetterie ou l'existence des fuites tant que la robinetterie soit accessible, avant que la partie encastrée devienne inaccessible. Noken Design se décharge de toute responsabilité dans le cas où cette prémisses ne soit pas respectée.

Leia atentamente as instruções antes de começar a instalação

- Verifique se o produto se encontra em bom estado.
- Qualquer alteração que se realize no sanitário perde a garantia.
- Aconselhamos que a instalação seja feita por um profissional qualificado.
- Em novas construções, após a colocação da sanita, bidé e lavatório, os sifões deverão ser preenchidos com água para evitar o aparecimento de oxidações nas torneiras e tampas de sanita pelo efeito da subida de gases corrosivos pelos tubos.
- Recomenda-se que o espaço esteja muito arejado.
- Testar a tubaria antes da instalação.
- Mantendo um cuidado periódico poderá evitar a formação de calcários.
- Resíduos de produtos de limpeza podem danificar as peças de metal, cromado ou vidro de sanitários, tais como dobradiças, embelezadores, botões, etc...
- As torneiras não deveriam se instalar onde a temperatura pode descer de 0°C, desde o gelar dos tubos poderia danificar a torneira.
- É responsabilidade do instalador comprovar que a temperatura máxima de funcionamento nunca será superior a 48°C já que as condições na obra podem ser diferentes as condições de fábrica baixo as que se regulou a torneira. Em caso de ser necessário, ajustar a temperatura máxima de funcionamento conforme indica-se nas instruções de montagem.

**-Atenção:** Lembre que é obrigatório verificar a existência de fugas antes de instalar a torneira e fazer o revestimento da parede, pois alguma das partes encastradas já não será logo acessível. Noken Design declina a terceiros toda a responsabilidade no caso de incumprimento de essa premissa.



● 100184779_N199999226	● 100190646_N199999149	● 100190680_N199999144
1	100210468_N292937516	100285828_N292937670
2	100210521_N292937518	100285807_N292937652
3	100210514_N292937519	100285840_N292937656
4	100210509_N292937517	100210509_N292937517
5	100211959_N292937526	100285819_N292937655
6	100211973_N292937525	100285829_N292937653
7	100212005_N292937521	100285831_N292937658
8	100046424_N234949931	100046424_N234949931
9	100212006_N292937522	100212006_N292937522
10	100212004_N292937523	100212004_N292937523
11	100060455_N252000003	100060455_N252000003
12	100212001_N292937524	100212001_N292937524
13	100211958_N292937520	100211958_N292937520
14	100184791_N199999224	100190667_N199999155
15	100202330_N292937444	100238775_N299998480
16	100060452_N252000004	100060452_N252000004

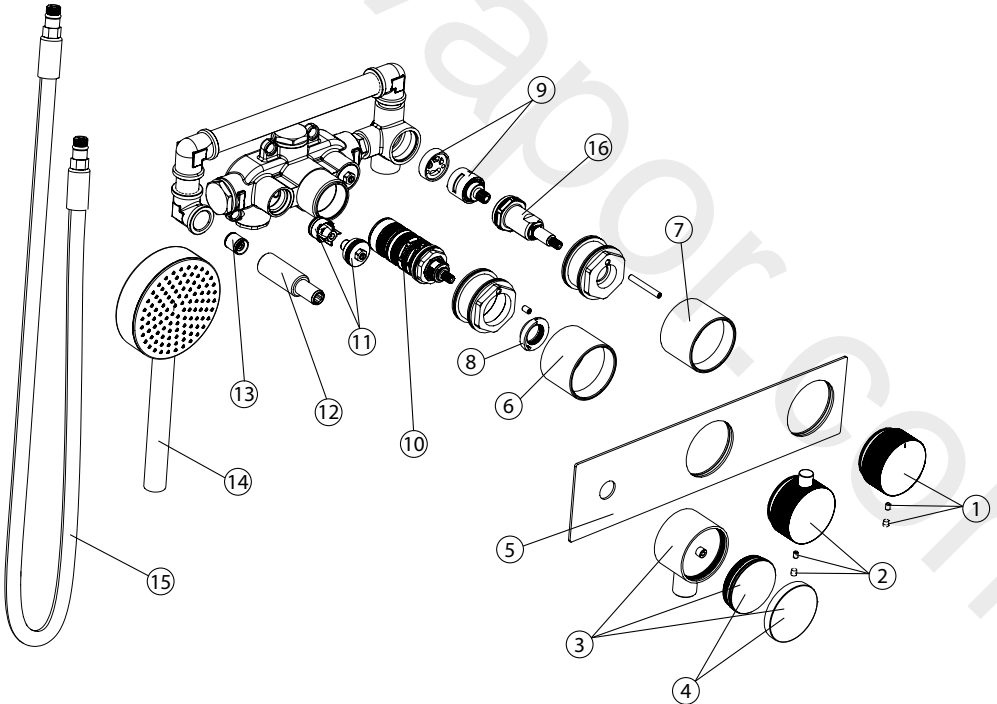

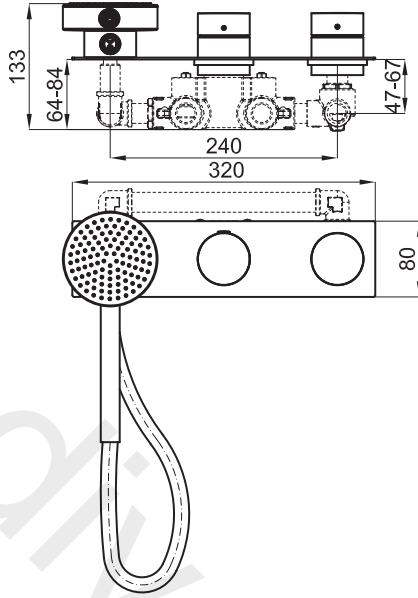

100184779\_N199999226

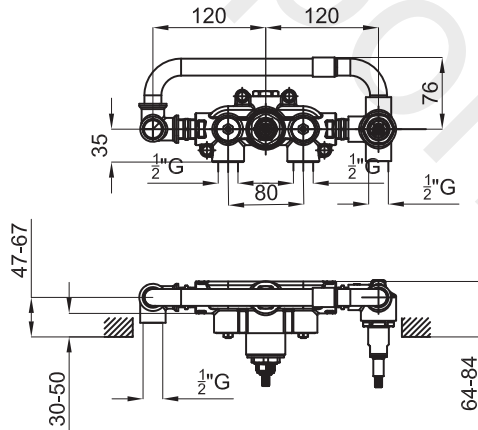

100190368\_N299998777

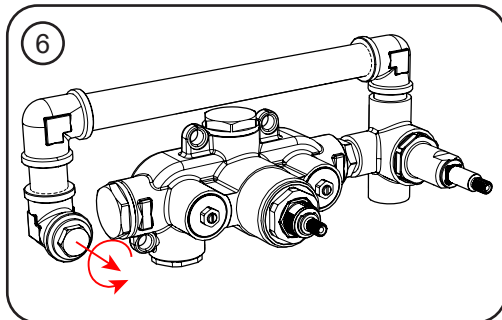
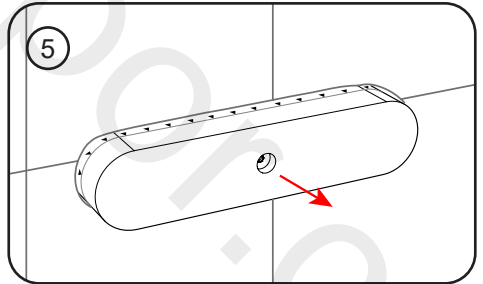
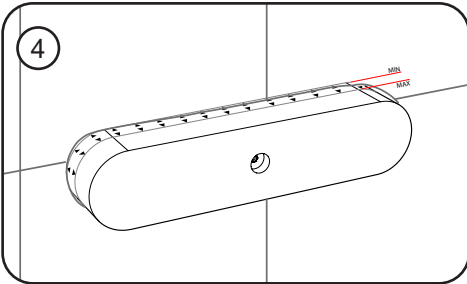
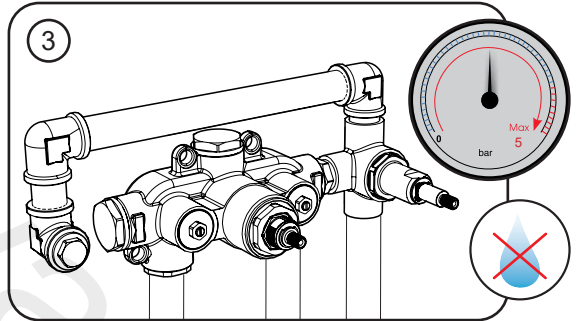
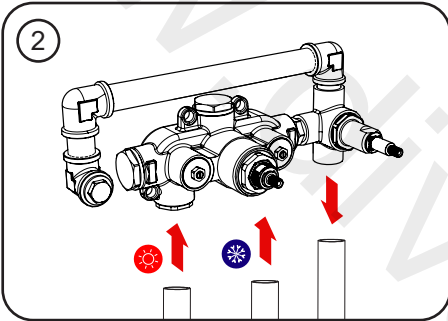
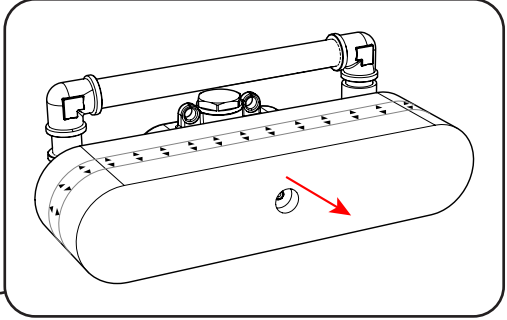
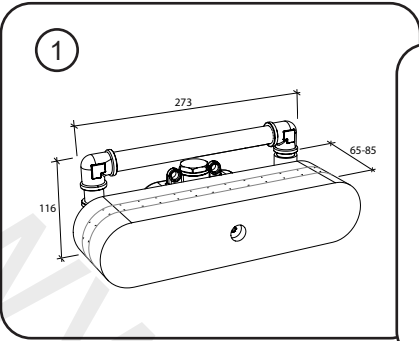

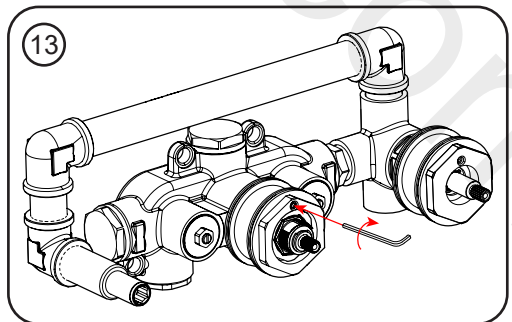
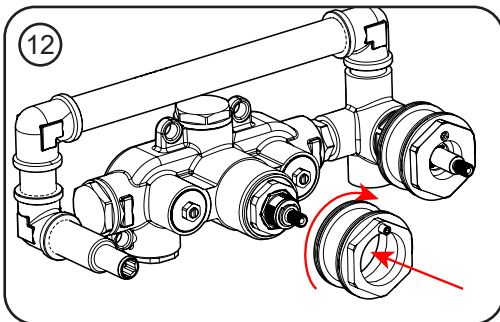
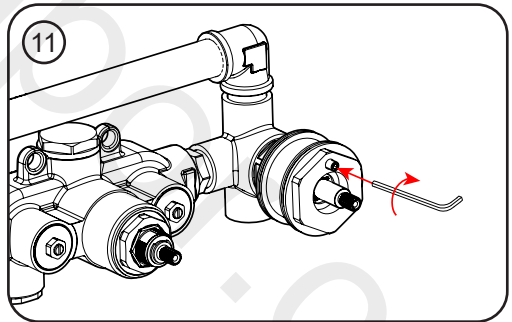
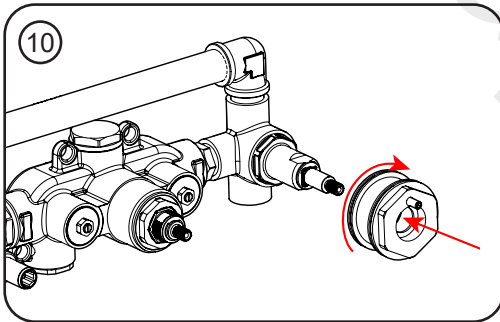
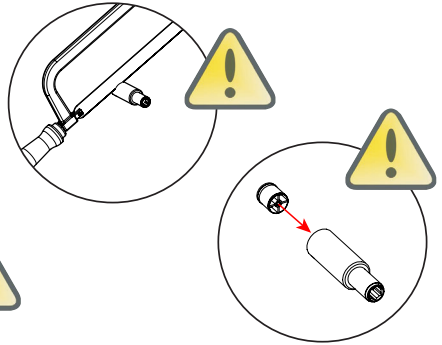
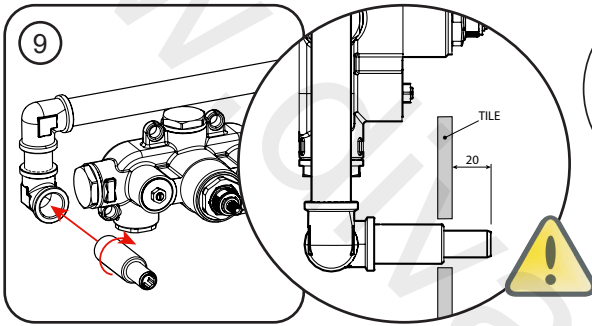
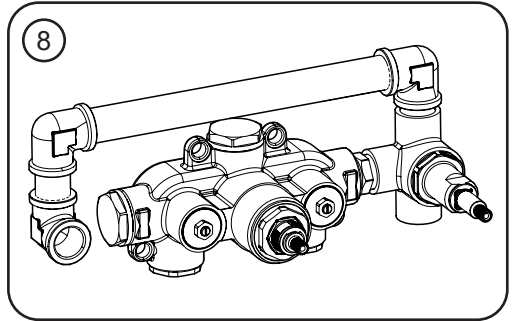
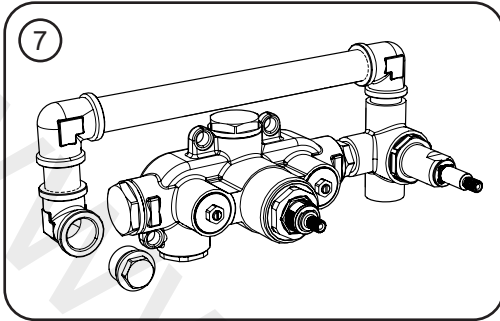

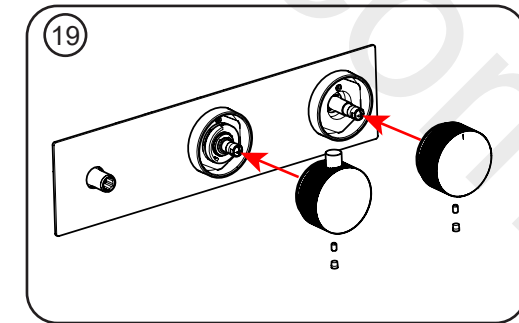
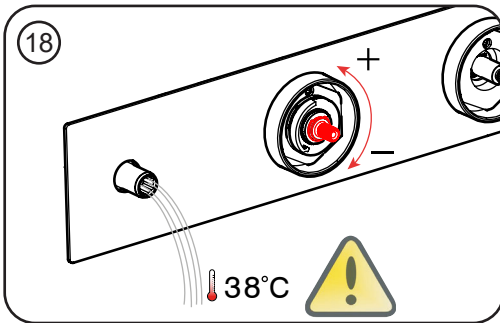
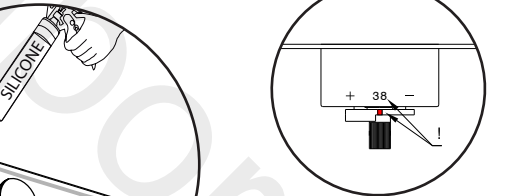
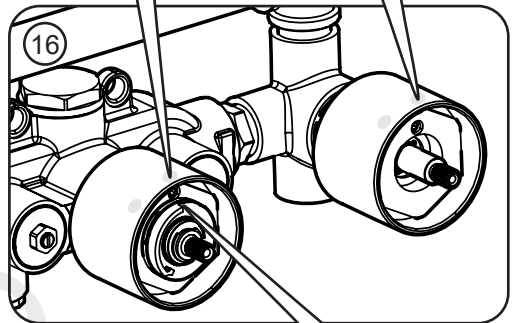
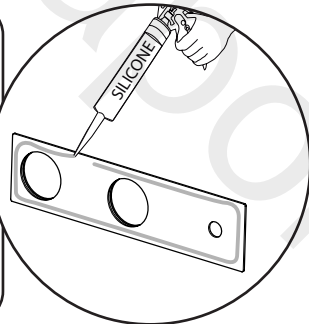
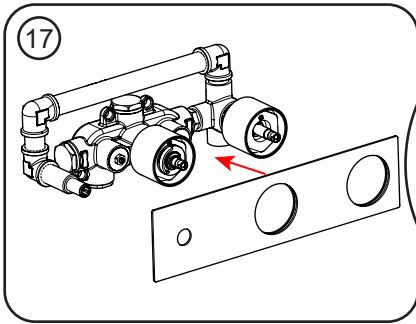
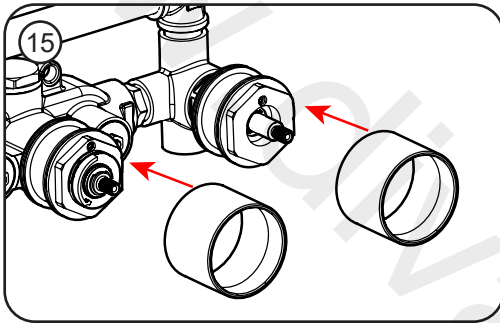
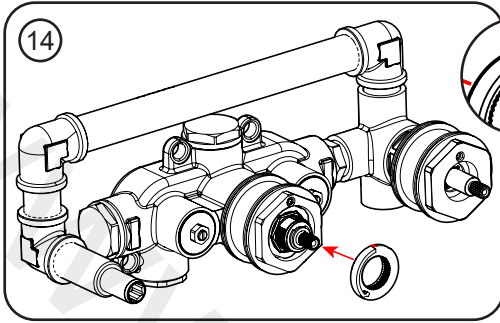

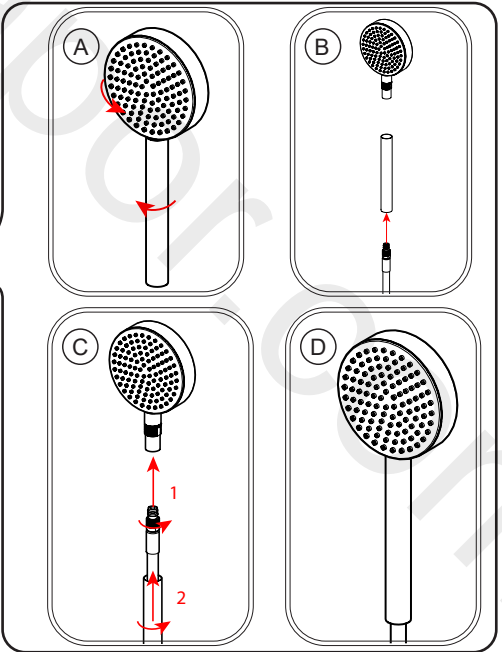
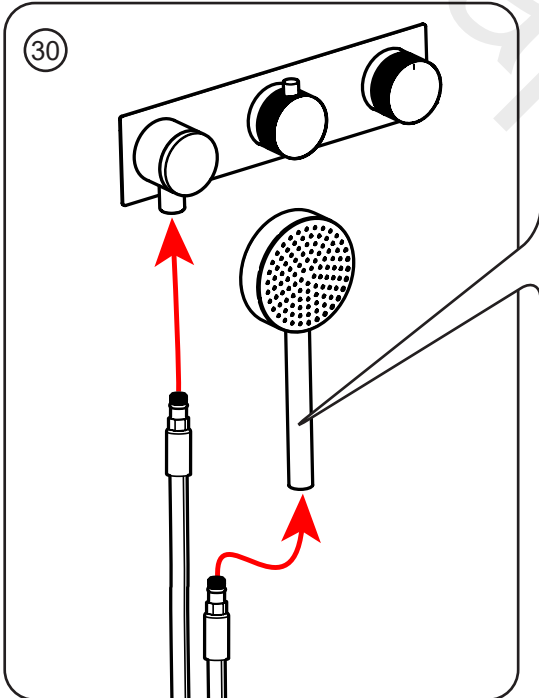
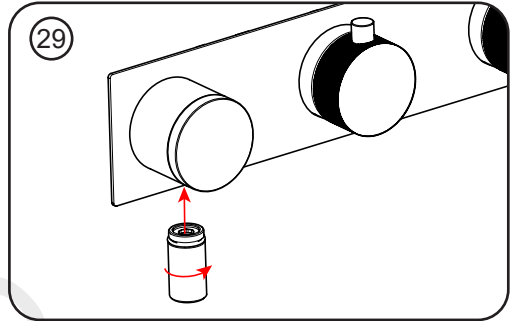
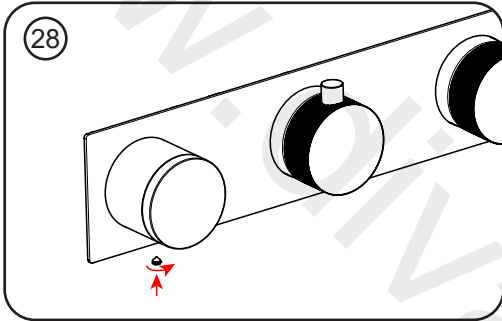
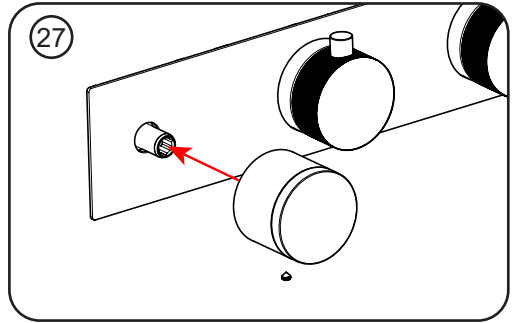
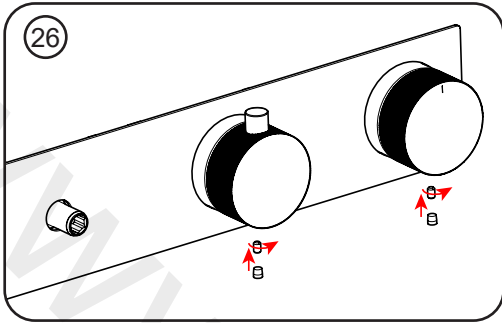





31

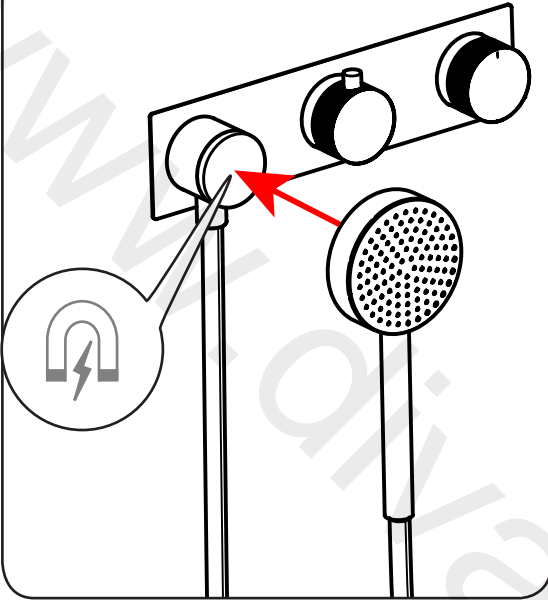

32

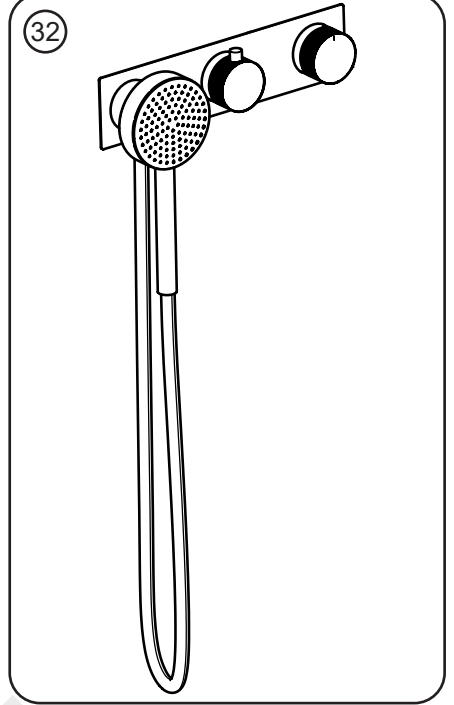

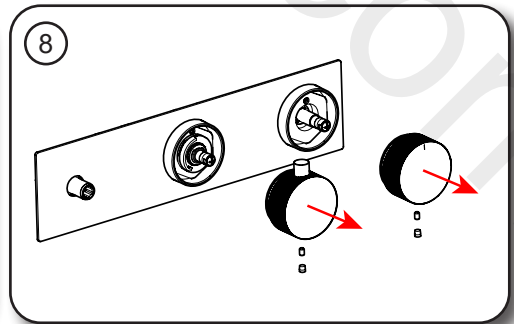
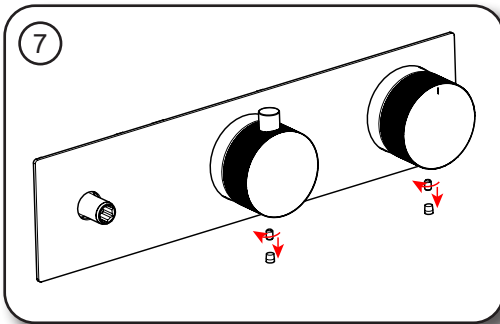
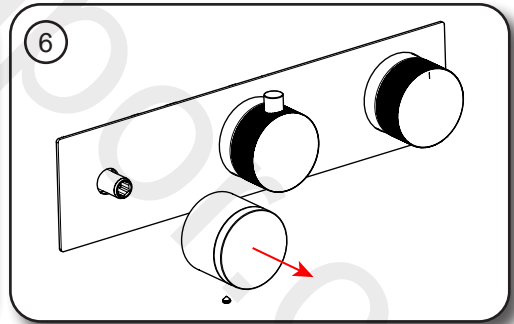
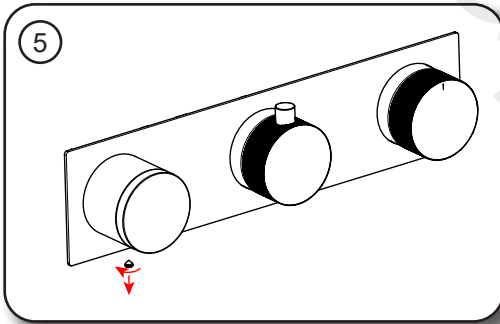
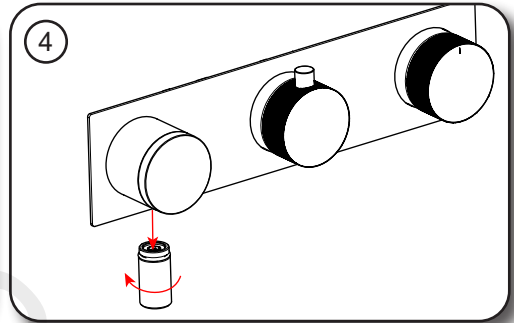
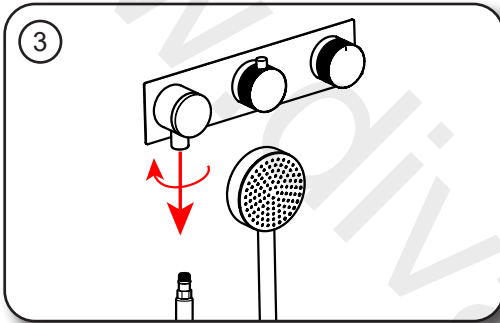
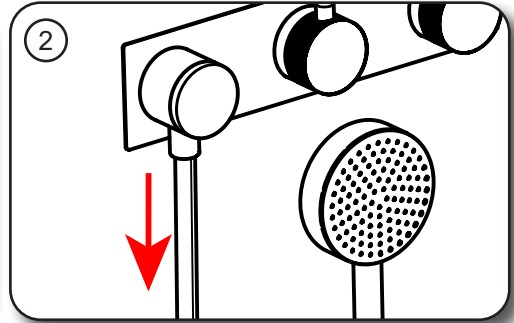
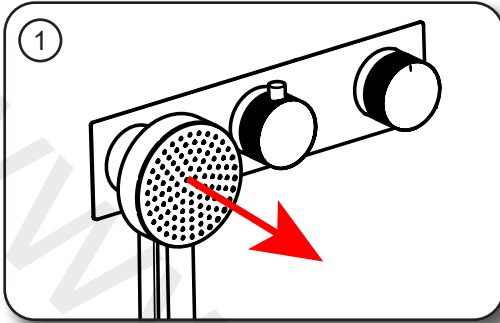

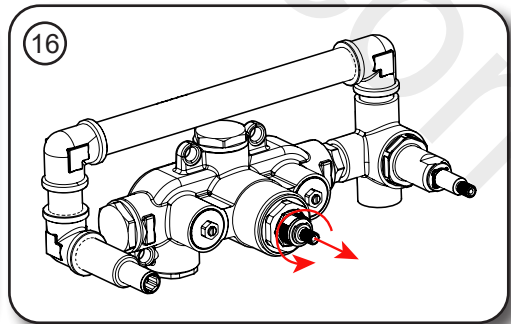
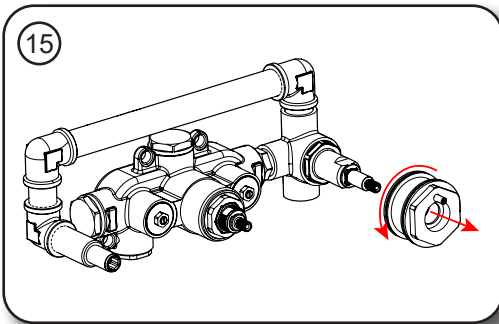
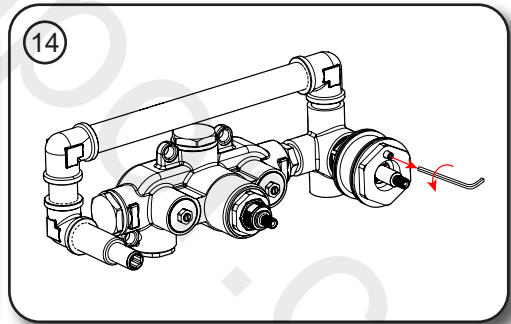
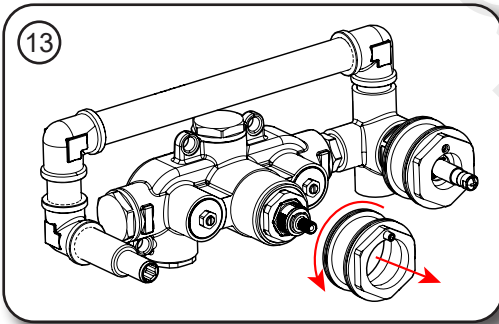
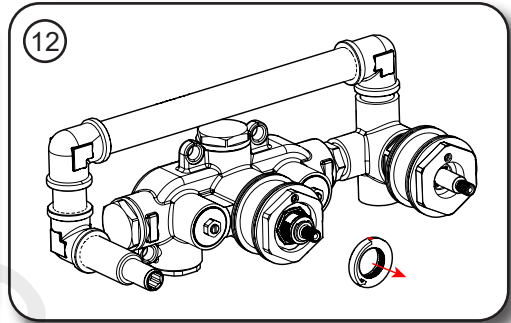
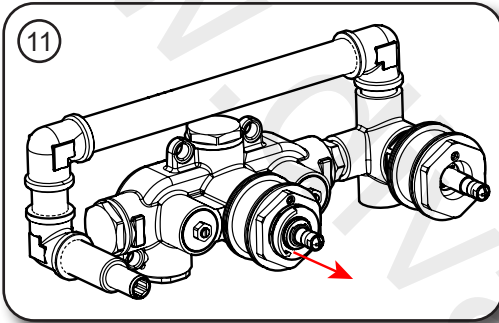
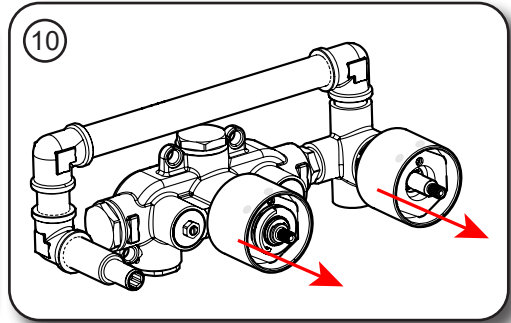
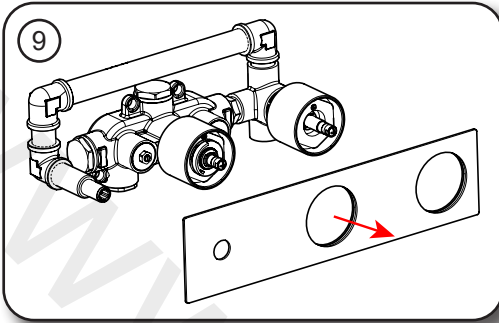

**A**

17

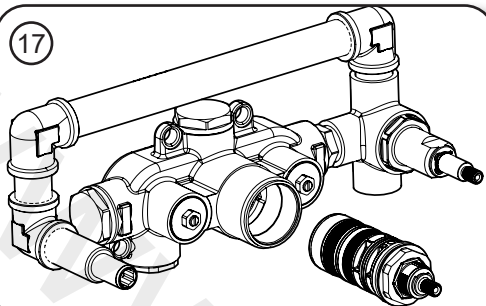

18

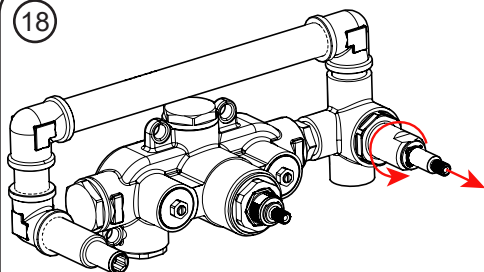
**B**

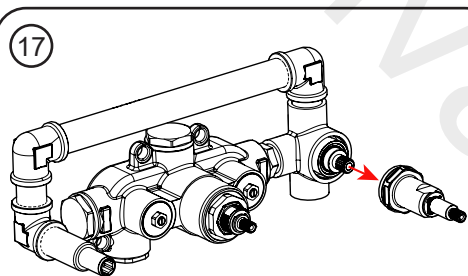

17

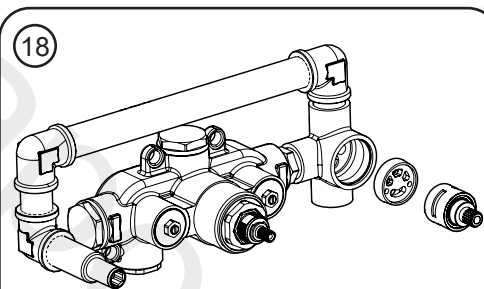

18

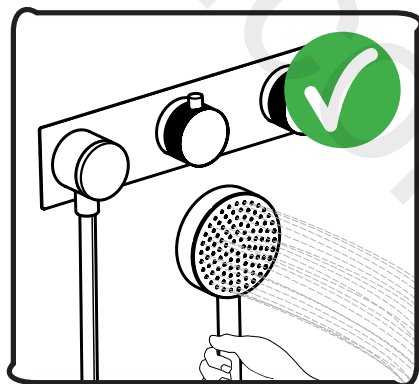
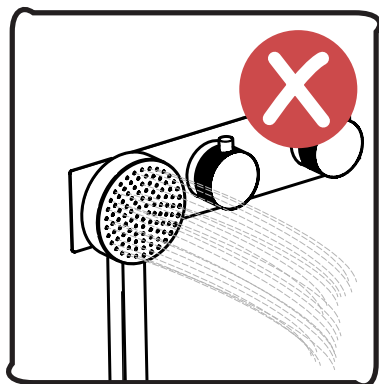
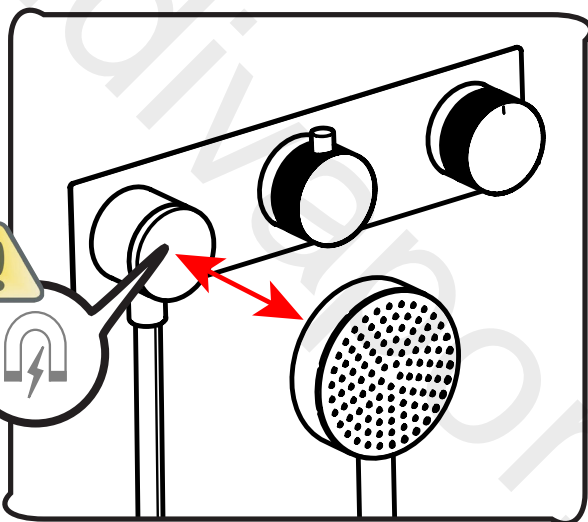
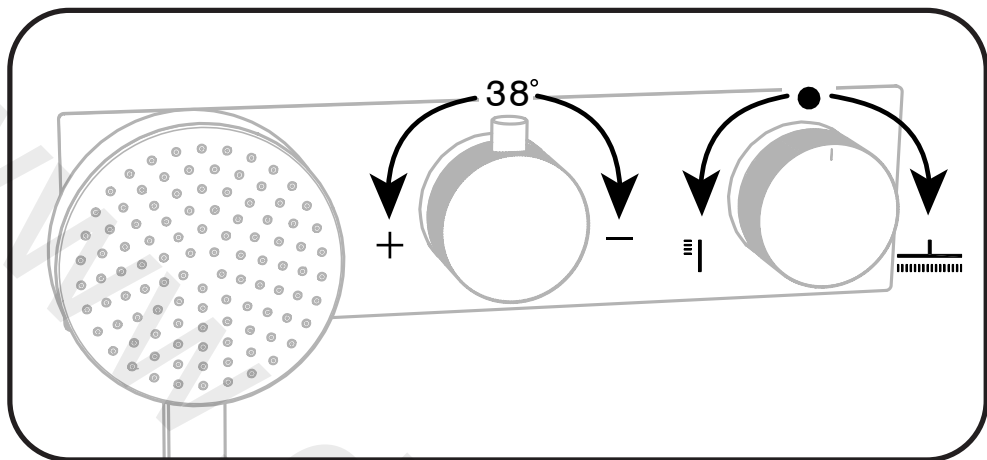

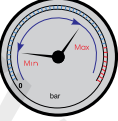

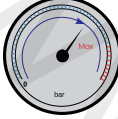
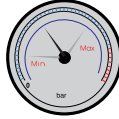
	Min.-Max. 0,5 - 5 bar	 Max. 70°C	Mixing system	
	Max. 5 bar		3 bar	Material Brass
		Coating	chrome nickel	$\geq 0,25 \mu\text{m}$ $\geq 10 \mu\text{m}$

Pressure (Bar)	FLOW RATE (l/min)	
	Bath	Shower
0,0	0,0	0,0
0,5	8,7	2,6
1,0	12,3	3,9
2,0	17,4	5,4
3,0	21,4	5,7
4,0	24,7	5,8
5,0	27,3	6,0

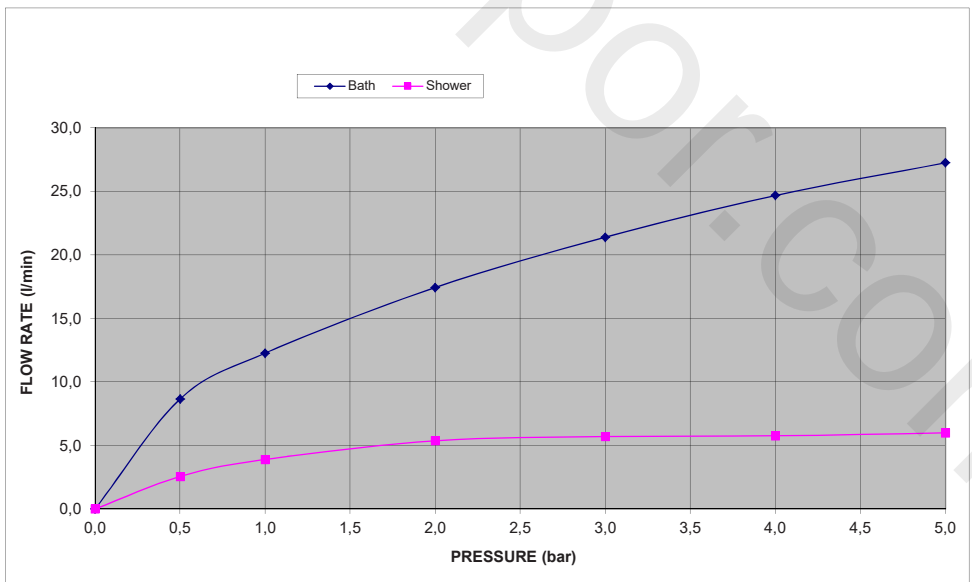

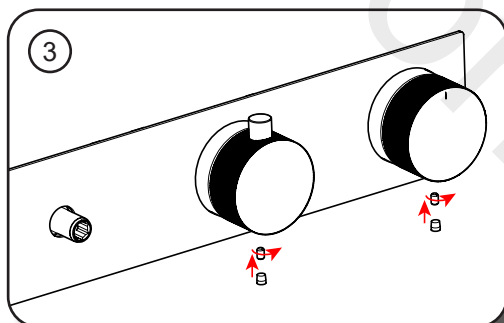
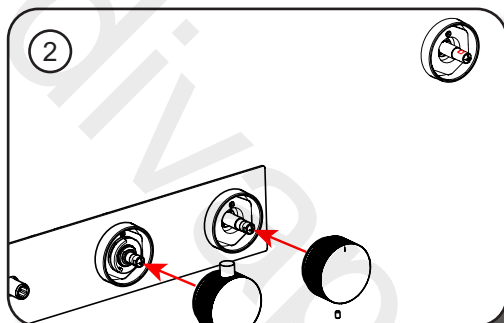
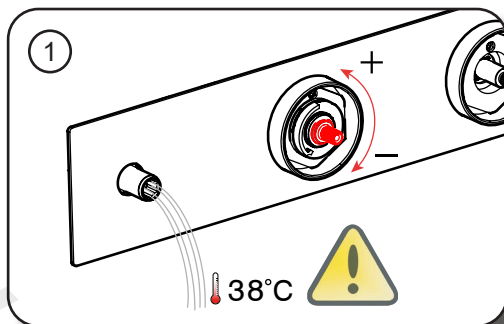



## GRIFERÍAS Y ACCESORIOS

En primer lugar, agradecerle la adquisición de productos Noken. Todos los productos Noken están fabricados con la confianza de dar un servicio fiable durante muchos años. Al igual que las griferías de otros fabricantes nuestros productos también exigen un cuidado apropiado y un mantenimiento que asegure a su baño una imagen impecable.

## SUPERFICIE DE LAS GRIFERÍAS

Conforme a los requerimientos de la norma DIN EN 248 la capa de protección que habitualmente más se utiliza para la fabricación de las griferías se compone de metales como cromo, níquel, acero y latón, así como de otros para evitar la humedad. Antes de emprender la limpieza es necesario examinar con exactitud el tipo de superficie que se vaya a limpiar.

## LIMPIEZA

Para la limpieza de las griferías y de los accesorios ha de tenerse en cuenta que:

- Para la limpieza periódica utilice agua caliente mezclada con jabón, si esto no es posible también puede usar geles o limpiadores líquidos, enjuagando siempre a fondo con agua limpia tras su uso.
- Aunque fueran empleados una sola vez, no debe utilizarse ningún producto que contenga ácido fosfórico, clorhídrico, muriático, fórmico o acético, ya que podrían producir daños considerables. Utilice un PH neutro.
- Secar los artículos tras cada sesión de limpieza y tras cada uso para evitar la acumulación de cal.

## ADVERTENCIA

- Los productos de limpieza acentúan el deterioro en caso de que las superficies ya se encuentren dañadas.
- No mezcle limpiadores, las reacciones químicas pueden emitir gases tóxicos.
- No use estropajos agresivos ni limpiadores abrasivos.
- Bajo ningún concepto se debe utilizar para la limpieza de estas superficies lejías de blanquear con cloro.
- Únicamente deben utilizarse los productos de limpieza expresamente indicados por los fabricantes para cada tipo de superficie y acabado.

## RECOMENDACIONES PARA LA LIMPIEZA Y CONSERVACIÓN DE GRIFERÍAS Y ACCESORIOS

- Lea primero las instrucciones del fabricante.
- La limpieza periódica reducirá la formación de cal y suciedad.
- Los productos de limpieza no debe emplearse durante más tiempo del necesario.
- Si utiliza productos de limpieza con pulverizador, no pulverice directamente sobre la grifería y los accesorios, aplíquelo sobre un paño o una esponja. El líquido pulverizado podría introducirse por los huecos y grietas de la grifería y los accesorios pudiendo causar daños irreversibles.
- Si el grifo gotea puede causar manchas y placas de cal, por favor asegúrese de que quede correctamente cerrado.
- Si es necesario puede usar su limpiador anti-cal habitual, pero lea primero las instrucciones del fabricante y tras su uso enjuague siempre la grifería con agua limpia.
- Para proteger la mecánica de la grifería y alargar la vida útil de ésta, Noken recomienda la instalación de llaves de paso con filtros.

## CLÁUSULA REFERENTE A LA GARANTÍA

No respetar las indicaciones de mantenimiento puede tener como consecuencia la invalidación de la garantía.

## BRASSWARE AND ACCESSORIES

First of all we thank you for buying our products which are manufactured to the highest standards. However in common with other products our brassware requires the correct cleaning and periodic maintenance.

## BRASSWARE SURFACES

As stated in the norm DIN EN 248 the materials used to plate brassware are Chrome, Nickel, stainless steel, brass and others to leave a superior, easy to clean, pleasing finish. Before cleaning please check the material used and only use a suitable cleaner.

## CLEANING

To clean brassware and accessories please note the following recommendations.

- For regular cleaning only use warm soapy water, if this is not possible use soft non abrasive gels or similar cleaning products, rinse thoroughly and polish with a soft cloth.
- Please avoid the use of harsh or abrasive products such as scouring powders, those products with phosphoric acid, hydrochloric acid, formic acid or acetic acid that could badly damage the product. Please only use PH neutral products.
- Dry the items after each cleaning session and after every use to avoid limestone appearance.

## WARNING

- Cleaning materials will only worsen already damage product.
- Do not mix cleaning products, the chemical reactions can emit toxic fumes and react badly with product surfaces.
- Do not use harsh or abrasive cloths, pads or cleaning products.
- Do not use bleach or other chlorine based cleaning products.
- Only use suitable cleaning products as recommended for each product the cleaning products only make worse the surfaces if those are already damages.

## RECOMMENDATIONS FOR THE CLEANING AND PRESERVATION OF BRASSWARE AND ACCESSORIES

- Read the manufacturers instructions.
- To protect the brassware, internal mechanism and to extend the life of the product it is recommended in line with "best practice" to install isolation valves and in line filters.
- Regular cleaning to reduce lime scale and soap residue build up.
- Do not leave these products in contact with the product surface longer than the manufacturer's recommendations and rinse thoroughly with clean water.
- Do not spray cleaning products directly onto the product surface, spray onto a soft cloth and then apply to the product. Spraying directly onto the product can lead to cleaning fluids being drawn into the products through capillary action causing irreversible damage.
- If a tap is left dripping it may lead to staining and lime scale build up. Please ensure taps are correctly turned off after use.

## GUARANTEE CLAUSE

- Failure to comply with the maintenance instructions may invalidate the guarantee.





## ROBINETTERIES ET ACCESSOIRES

Tout d'abord, nous tenons à vous remercier pour avoir choisi un produit Noken. Tous nos produits sont fabriqués dans le but de donner un service fiable durant de nombreuses années. Pour assurer une image impeccable de votre salle de bains, nos robinetteries, comme celles d'autres fabricants, nécessitent un soin et un entretien approprié.

## LES SUPERFICIES DES ROBINETTES

Conformément aux exigences de la norme DIN EN 248, la couche de protection qui s'utilise le plus souvent pour la fabrication des robinetteries se compose de métaux tels que le chrome, le nickel, l'acier et le laiton ainsi que certains autres pour éviter l'humidité. Avant de commencer l'entretien, il est nécessaire d'examiner avec exactitude le type de superficie qui se nettoiera.

## ENTRETIEN

Pour l'entretien des robinetteries et des accessoires, il faut prendre en compte certains détails:

- Pour l'entretien régulier, utiliser de l'eau chaude mélangée avec du savon. Si ce n'est pas possible, on peut utiliser des gels ou des produits d'entretien liquides, en rinçant toujours intensément avec de l'eau propre après usage.
- Ne pas utiliser de produits contenant de l'acide phosphorique, chlorhydrique, muriatique, formique ou acétique, même une seule fois, vu qu'ils pourraient occasionner des dégâts considérables. Utiliser un Ph neutre.
- Séchez les articles après chaque session de nettoyage et après chaque utilisation pour éviter l'accumulation du calcaire.

## AVERTISSEMENT

- Les produits d'entretien accentuent la détérioration dans le cas où les surfaces se trouvent déjà endommagées.
- Ne pas mélanger les produits d'entretien ensemble. Les réactions chimiques peuvent émettre des gaz toxiques.
- Ne pas utiliser d'éponges métalliques agressives ni de produits d'entretien abrasifs.
- Sous aucun prétexte il ne faut utiliser d'eau de javel à blanchir avec du chlore pour nettoyer ces superficies.
- Il faut seulement utiliser les produits d'entretien expressément indiqués par les fabricants pour chaque type de superficie et de finition.

## RECOMMANDATIONS POUR L'ENTRETIEN ET LA CONSERVATION DES ROBINETTERIES ET DES ACCESSOIRES

- Lire avant tout la notice du fabricant.
- L'entretien régulier réduira la formation de calcaire et de saletés.
- Les produits d'entretien ne doivent pas s'utiliser plus longtemps que le temps recommandé.
- Si on utilise des produits d'entretien avec pulvérisateur, ne pas l'appliquer directement sur la robinetterie ou les accessoires mais sur un chiffon ou une éponge. Le liquide pulvérisé pourrait s'introduire dans les creux et les fentes de la robinetterie et des accessoires, pouvant causer des dommages irréversibles.
- Si la robinetterie goute, elle peut causer des tâches de calcaire. Il faut s'assurer que la robinetterie soit fermée correctement après chaque usage.
- Si nécessaire, vous pouvez utiliser votre produit anti-calcaire habituel, mais lisez d'abord la notice du fabricant et après usage, rincez toujours la robinetterie à l'eau claire.
- Pour protéger le mécanisme interne de la robinetterie et allonger la vie utile de celle-ci, Noken recommande l'installation de robinets d'arrêt avec le filtre.

## CLAUDE DE LA GARANTIE

Ne pas respecter les indications d'entretien peut avoir comme conséquence l'invalidation de la garantie.

## TORNEIRAS E ACESSÓRIOS

Em primeiro lugar, obrigado pela compra de produtos Noken. Na Noken Todos os produtos são feitos com a confiança necessária para dar um serviço de confiança por muitos anos. Como outros produtos de fabricantes acessórios também precisam de cuidados e manutenção adequada para garantir que a sua casa de banho apresente um aspecto impecável

## SUPERFÍCIE DAS TORNEIRAS

De acordo com os requisitos da norma DIN EN 248 camada protetora que é MAIS COMUM utilizar para a fabricação de acessórios incluem metais como cromo, níquel, aço e latão, bem como outros para evitar a humidade. Antes de proceder à limpeza é necessário examinar exactamente o tipo de superfície a ser limpa.

## LIMPEZA

Para a limpeza de torneiras e acessórios deve-se ter em atenção:

- Apesar de terem sido utilizadas apenas uma vez, todos os produtos que contêm fosfóforo, clorídrico, muriático, ácido fórmico ou ácido acético, uma vez que podem causar danos consideráveis não devem ser usados. Use um PH neutro.
- Embora os funcionários foram uma vez, qualquer produto que contenha fosfórico, clorídrico, muriático, ácido fórmico ou acético, pois podem causar danos consideráveis não deve ser usado. Use um PH neutro.
- Seque os artigos depois de cada sessão de limpeza e depois de cada utilização para evitar a acumulação de calcário.

## ATENÇÃO

- Produtos de limpeza acentuam a deterioração se as superfícies já estão danificadas.
- Não misture produtos de limpeza, as reações químicas podem emitir gases tóxicos.
- Não utilize esfregões abrasivos ou produtos de limpeza abrasivos.
- Sob nenhuma circunstância deve ser usado para limpar essas superfícies Lixívia.
- Deve-se utilizar unicamente produtos de limpeza expressamente indicados pelo fabricante para cada tipo de superfície e acabamento.

## RECOMENDAÇÕES PARA LIMPEZA E CONSERVAÇÃO DE TORNEIRAS E ACESSÓRIOS

- Leia as instruções do fabricante em primeiro lugar.
- A limpeza regular irá reduzir o calcário e sujidade.
- Produtos de limpeza não devem ser utilizados mais do que o necessário.
- Se usar um spray de limpeza, não pulverize diretamente na torneira e acessórios, aplicar num pano ou esponja. O spray líquido pode-se introduzir através dos furos e ranhuras dos equipamentos e pode causar danos irreversíveis.
- Em caso de vazamento de torneira pode causar manchas e placas de calcário, por favor, certifique-se que está bem fechada.
- Se necessário, pode utilizar o produto de limpeza anti-calcaire usual, mas devem-se ler as instruções do fabricante em primeiro lugar e só depois utilizar, lavar sempre a torneira com água limpa.
- Para proteger a mecânica da torneira e prolongar a vida útil da mesma, Noken recomenda a instalação de válvulas com filtros.

## Cláusula relativa à GARANTIA

Não seguir as instruções de manutenção pode resultar na anulação da sua garantia.

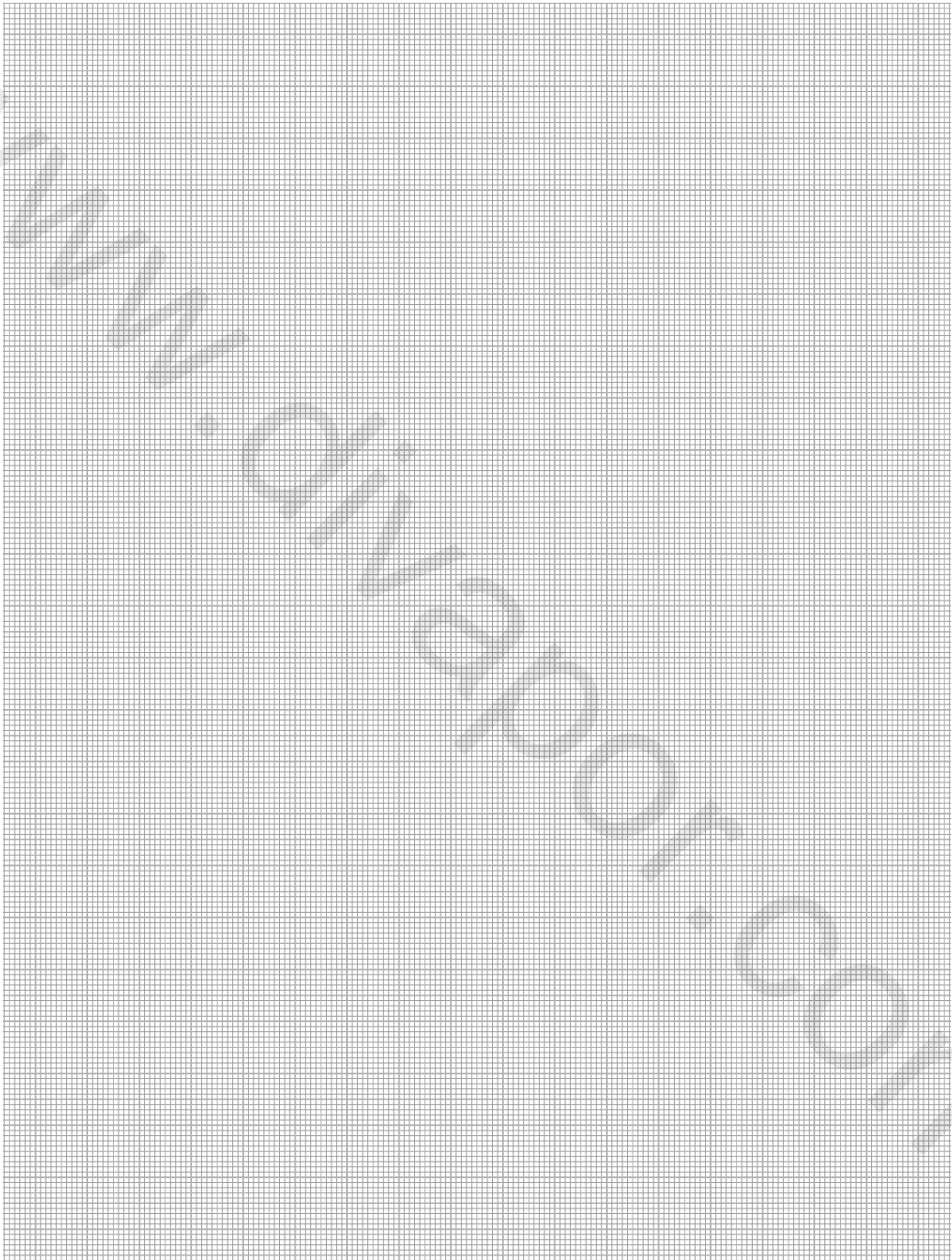



## PORCELANOSA BATHROOMS



[www.noken.com](http://www.noken.com)

Para consultar la garantía u otra información relativa a este producto, visitar nuestra web:

For a warranty or other information on this product, visit our Web address:

Pour obtenir une garantie ou d'autres informations sur ce produit, visitez notre site web:

Para garantia ou outras informações sobre este produto, visite o nosso site:

Per consultare la garanzia o altre informazioni relative a questo prodotto, visitare il nostro sito Web:

Hinweise zur Garantie und zu sonstigen Einzelheiten zu dem Produkt finden Sie auf unserer Webseite:

Для получения гарантийной или другой информации, связанной с данным продуктом, посетите наш веб-сайт:

Aby zapoznać się z gwarancją lub innymi informacjami związanymi z danym produktem, odwiedź naszą stronę internetową:

关于这个产品的保修及其它信息，请访问我司的网站参看。

تنترتن إلى علع ان عقوم ةرايز اجرا لء، جت نمن الم اذهب ةقل عتم ىرخا تامول عم يا وا ةلافك لة عجارم ل