



www.divaporo.com



100307799

noken
PORCELANOSA BATHROOMS

Carretera CV-20 km.2 · 12540 Vila-real · Castellón · Spain
Tel: +34 964 50 64 50 - Fax: +34 964 50 67 93
e-mail: noken@noken.com · www.noken.com

TONO



-Este artículo pueden utilizarlo niños con edad de 8 años y superior y personas con capacidades físicas, sensoriales o mentales reducidas o falta de experiencia y conocimiento, si se les ha dado la supervisión o formación apropiadas respecto al uso del aparato de una manera segura y comprenden los peligros que implica. Los niños no deben jugar con el aparato. La limpieza y el mantenimiento a realizar por el usuario no deben realizarlos los niños sin supervisión.

- La instalación debe ser realizada exclusivamente por un instalador cualificado y respetando las indicaciones de los manuales.

- La instalación se debería realizar de acuerdo con las regulaciones de cableado vigentes en su país. Asegúrese de que el circuito al que se va a conectar el producto, haya sido instalado y protegido de acuerdo con las normas de instalación vigentes en su país.

- Si el cable de alimentación está dañado, debe ser sustituido por el servicio postventa Noken o por personal cualificado similar con el fin de evitar un peligro

- This product can be used by children aged from 8 years and above and persons with reduced physical, sensory or mental capabilities or lack of experience and knowledge if they have been given supervision or instruction concerning use of the appliance in a safe way and understand the hazards involved. Children shall not play with the appliance. Cleaning and user maintenance shall not be made by children without supervision.

- The product must only be installed by trained plumbing engineers following strictly the manual guidelines.

- The installation should be in accordance with the wiring regulations in force at your country. Make sure the circuit you are connecting to the product, has been installed and protected to the installation standards in force at your country.

- If the power cord cable is damaged, it must be replaced by the Noken after-sales service or by similar qualified person in order to avoid a danger.

-Cet appareil peut être utilisé par des enfants âgés d'au moins 8 ans et par des personnes dont les capacités physiques, sensorielles ou mentales sont réduites ou dont l'expérience ou les connaissances ne sont pas suffisantes, à condition qu'ils bénéficient d'une surveillance ou qu'ils aient reçu des instructions quant à l'utilisation de l'appareil en toute sécurité et qu'ils comprennent bien les dangers encourus. Les enfants ne devraient pas jouer avec la baignoire. Le nettoyage et l'entretien par l'utilisateur ne doivent pas être effectués par des enfants, à condition qu'ils bénéficient d'une surveillance d'un adulte.

- L'installation doit être réalisée par un installateur qualifié et en respectant les indications du manuel.

- L'installation devra être réalisée en accord avec les réglementations de câblage en vigueur dans votre pays. Assurez vous que le circuit auquel, ait été installé et protégé en accord avec les normes d'installation en vigueur dans votre pays.

- Si le cordon d'alimentation est endommagé, il doit être remplacé par le service après-vente de Noken ou par un personnel qualifié similaire pour éviter tout danger.

-Este produto podem utilizá-la meninos com idade de 8 anos e superior e pessoas com capacidades físicas, sensoriales ou mentais reduzidas ou falta de experiência e conhecimento, se tem-se-lhes dado a supervisão ou formação apropriadas com respeito ao uso do aparelho de uma maneira segura e compreendem os perigos que implica. Os meninos não devem brincar com o aparelho. A limpeza e a manutenção a realizar pelo utilizador não devem os realizar os meninos sem supervisão.

- A instalação deve ser realizada por um técnico qualificado e respeitando as indicações dos manuais.

- Assegurar-se que o circuito onde se vai fazer a ligação, tenha sido instalado e protegido de acordo com as normativas vigentes no seu país.

- Se o cabo de alimentação estiver danificado, deve ser substituído pelo serviço pós-venda da Noken ou por pessoal qualificado semelhante, a fim de evitar um perigo

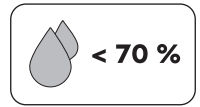
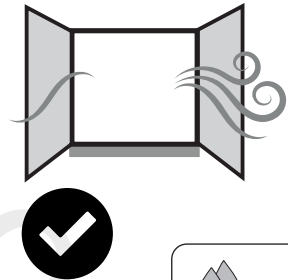
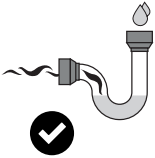
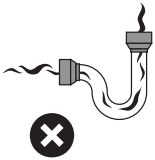
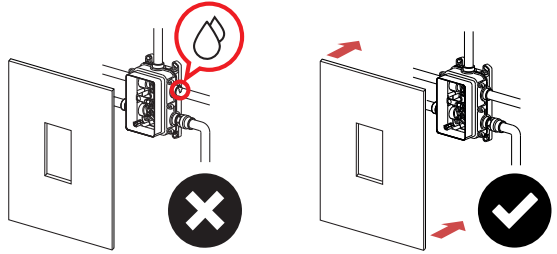
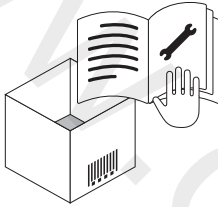
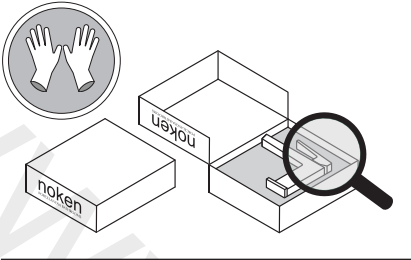

 **< 5° C**

 **> 5° C**

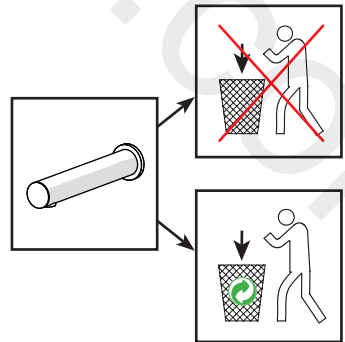
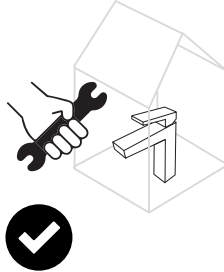
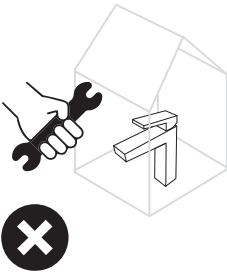

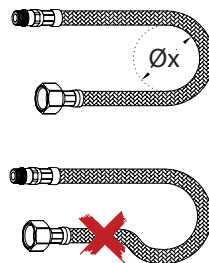
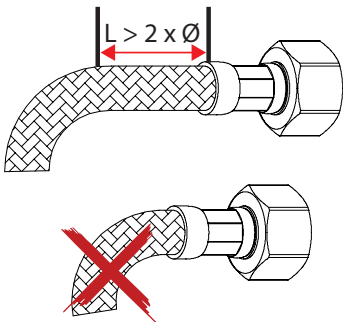
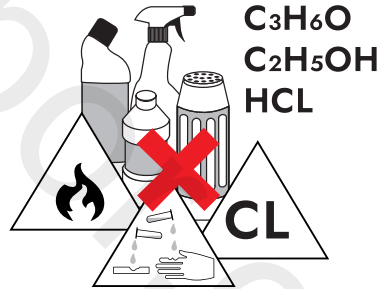
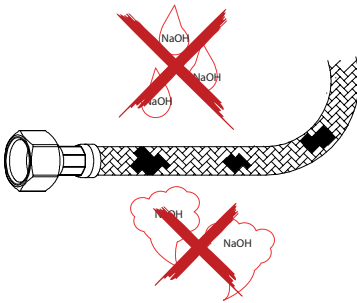
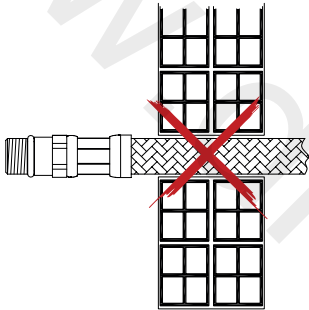
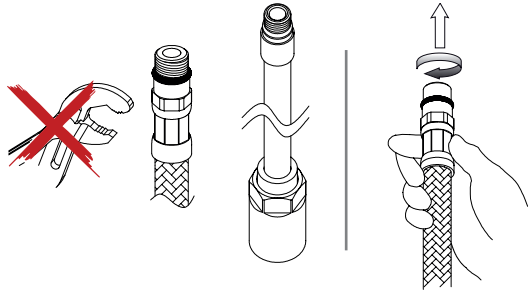
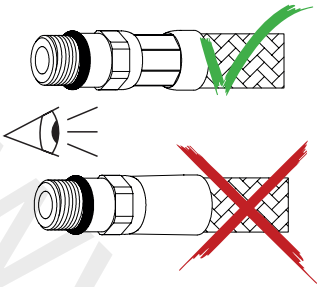

DN6 > Ø25mm
DN8 > Ø30mm
DN10 > Ø35mm
DN13 > Ø45mm



1	100319742
2	100321730
3	100202350
4	100202327
5	100319725
6	100319767
7	100319752
8	100319731

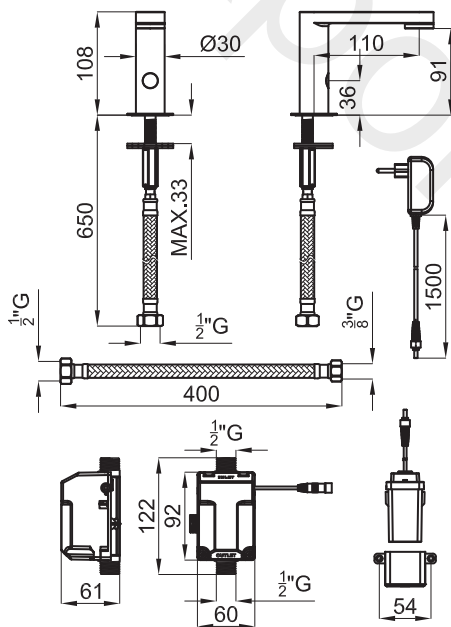
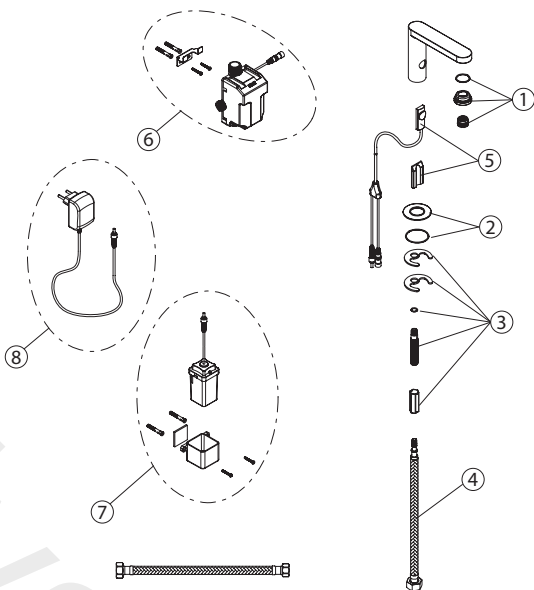

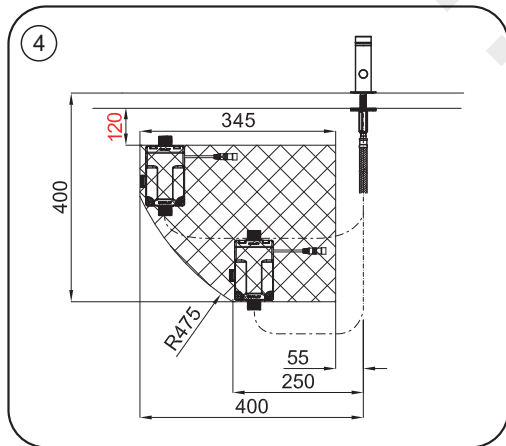
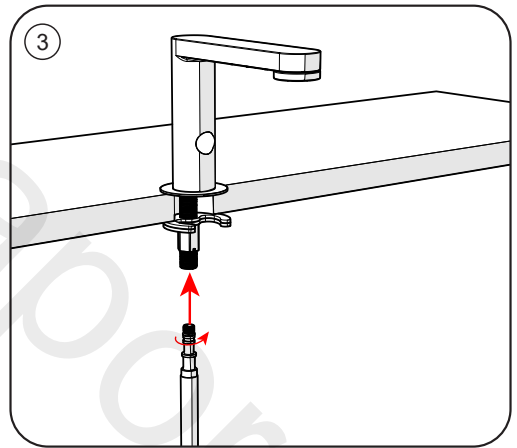
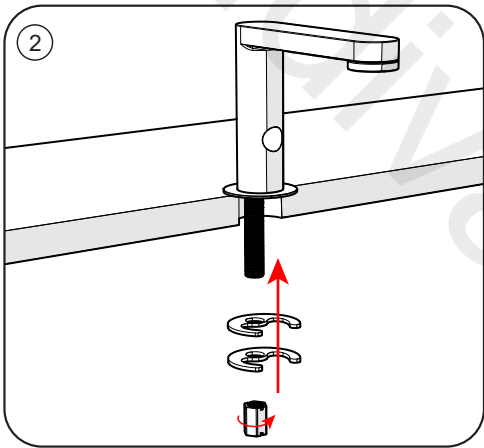
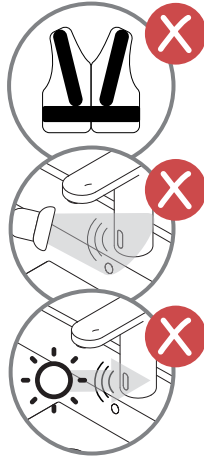
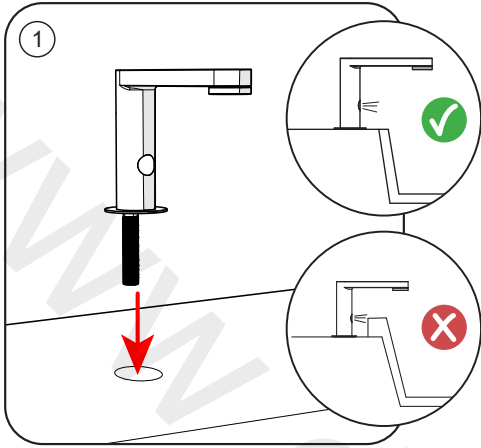

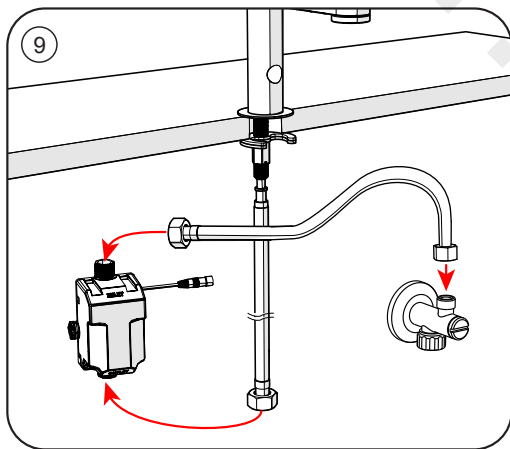
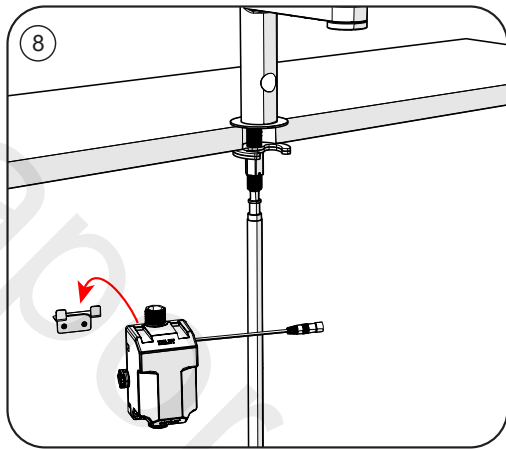
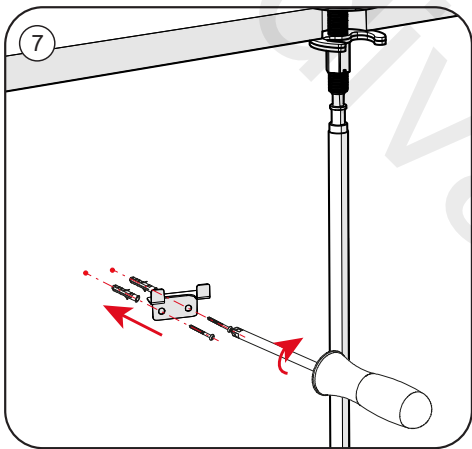
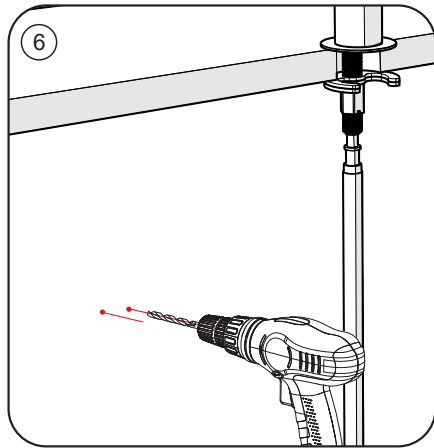
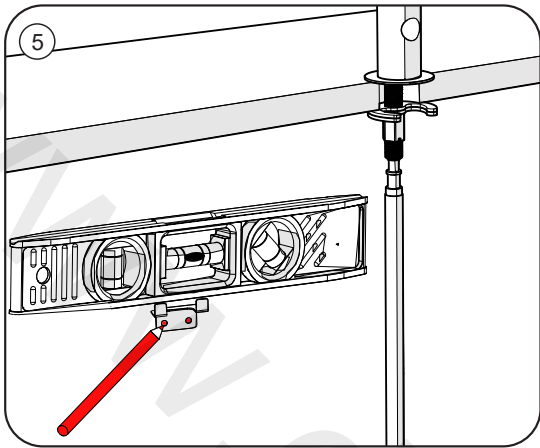

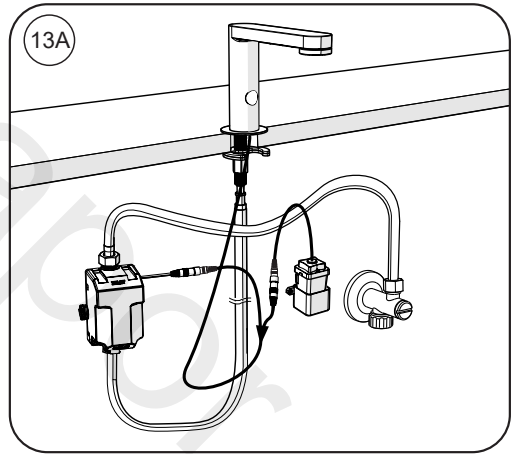
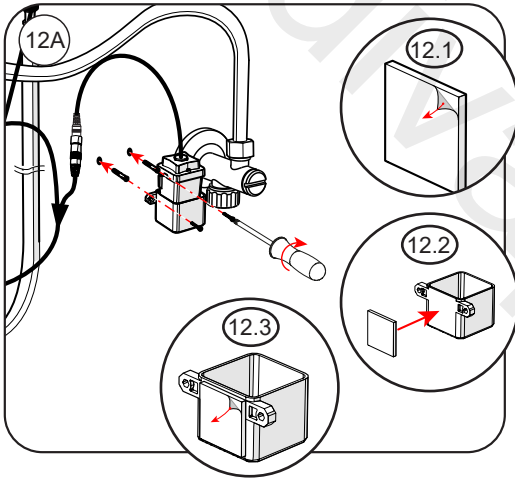
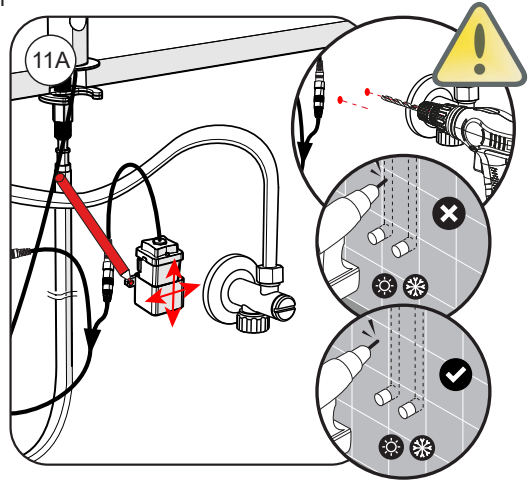
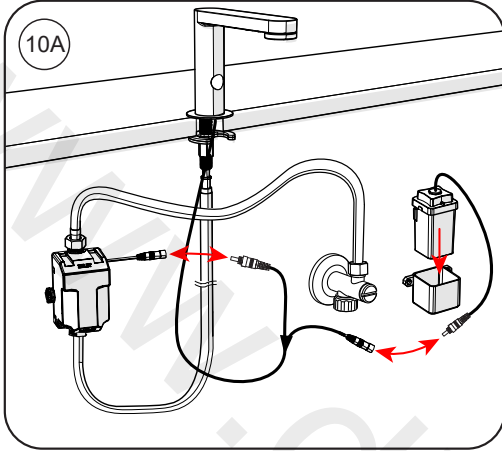



B



10B

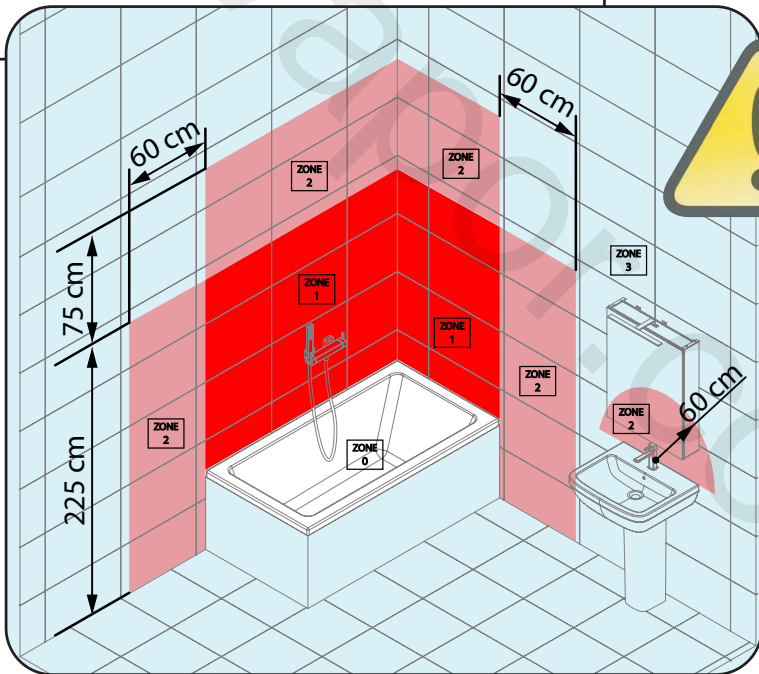
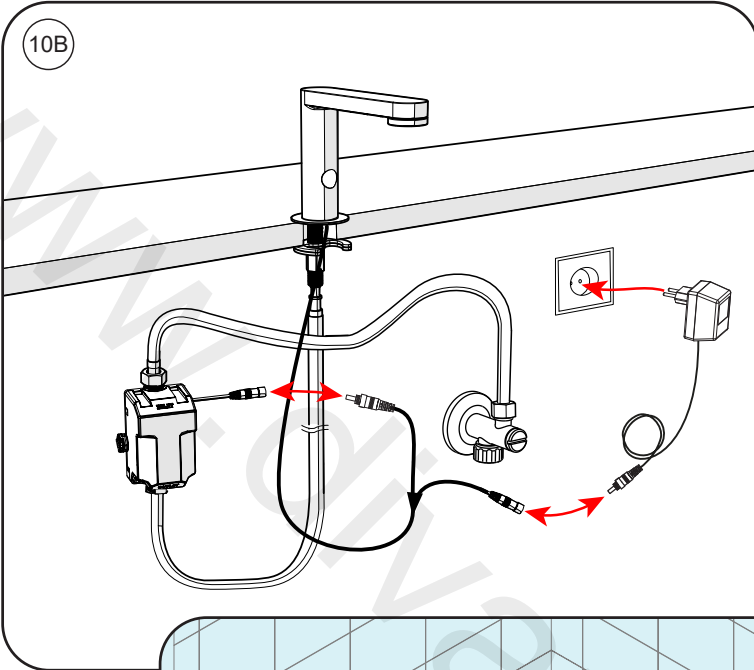

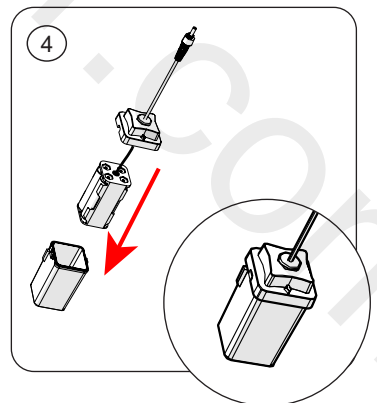
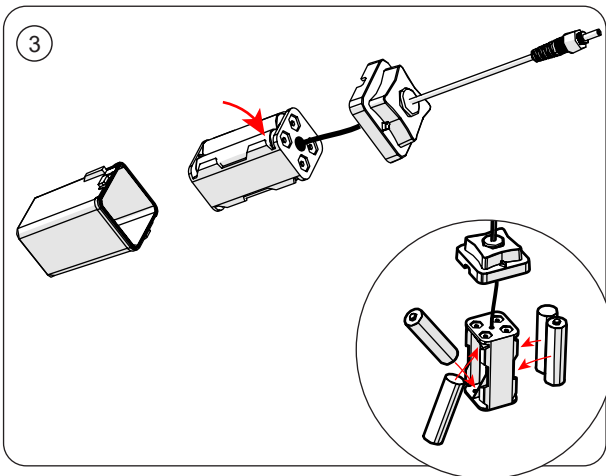
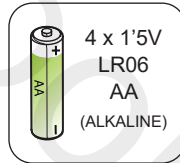
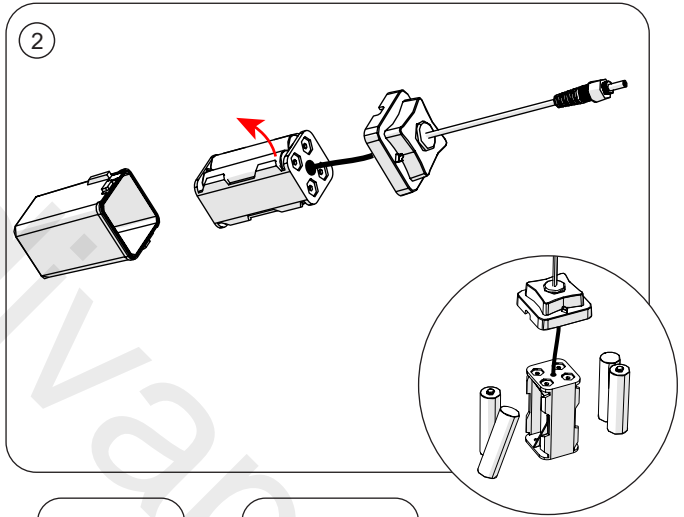
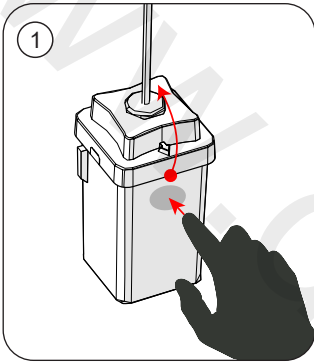
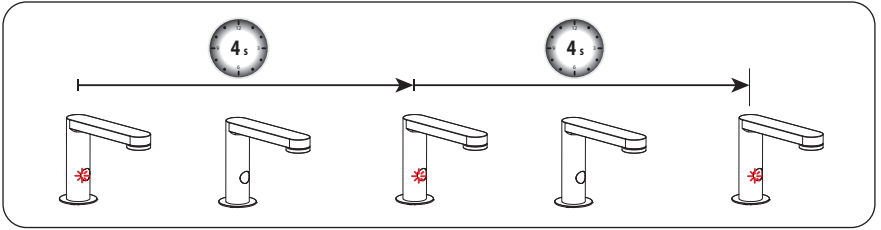
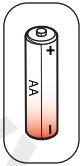

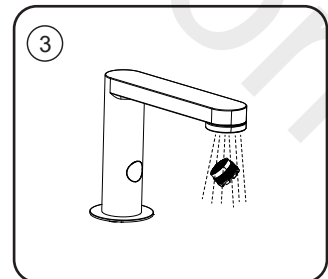
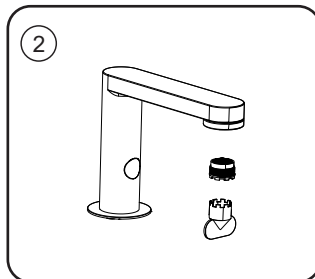
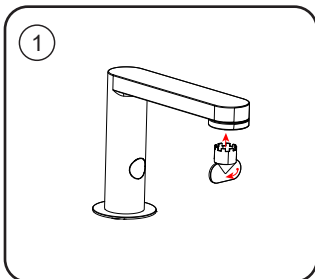
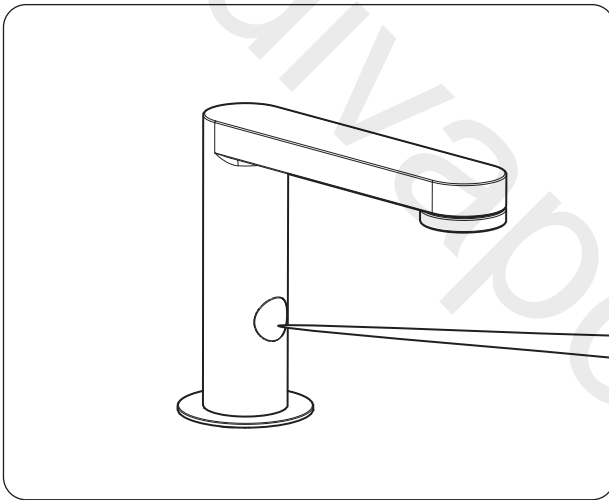
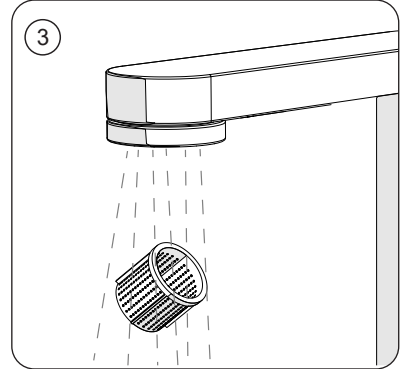
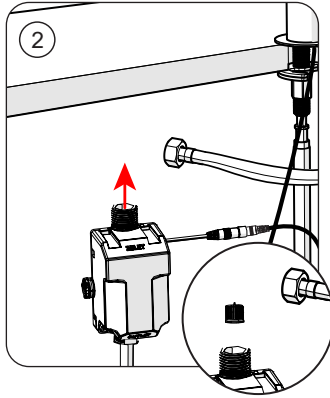
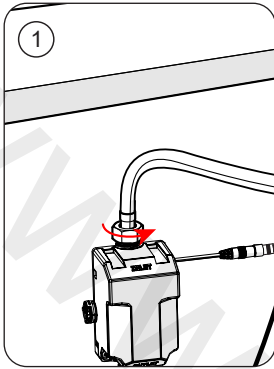

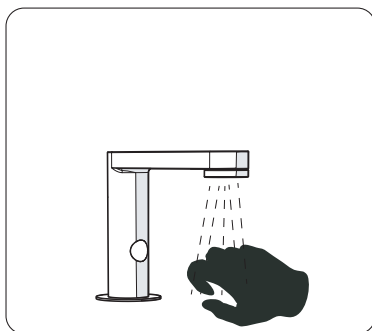
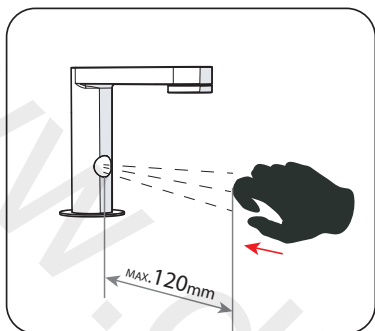

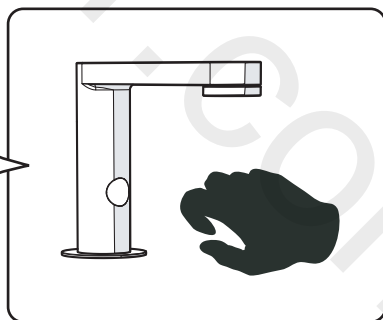
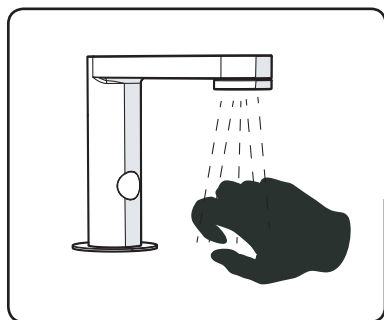

AUTOSTOP



A 	DC 6V (4 x 1'5V - AA)
B 	AC 100 - 240V / DC 6V
MAX. POWER	3W

**ALKALINE BATTERY
(INCLUDED)**

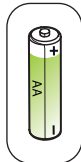



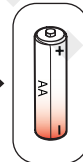

100%

1'5 AÑOS / YEARS / ANNÉE / ANO
O / OR / OU / OU
100.000 CICLOS / CYCLES / CYCLES / CICLOS

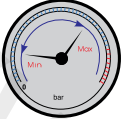

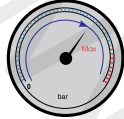
0%

 Min.-Max. 0,5 - 5 bar	 Max. 70°C	Mixing system		Ø
 Max. 5 bar	 3 bar	Material		Brass
		Coating	chrome nickel	≥ 0,25 µm
				≥ 10 µm

Pressure (Bar)	FLOW RATE (l/min)
0,0	0,0
0,5	1,9
1,0	3,3
2,0	4,5
3,0	5,5
4,0	5,5
5,0	5,4

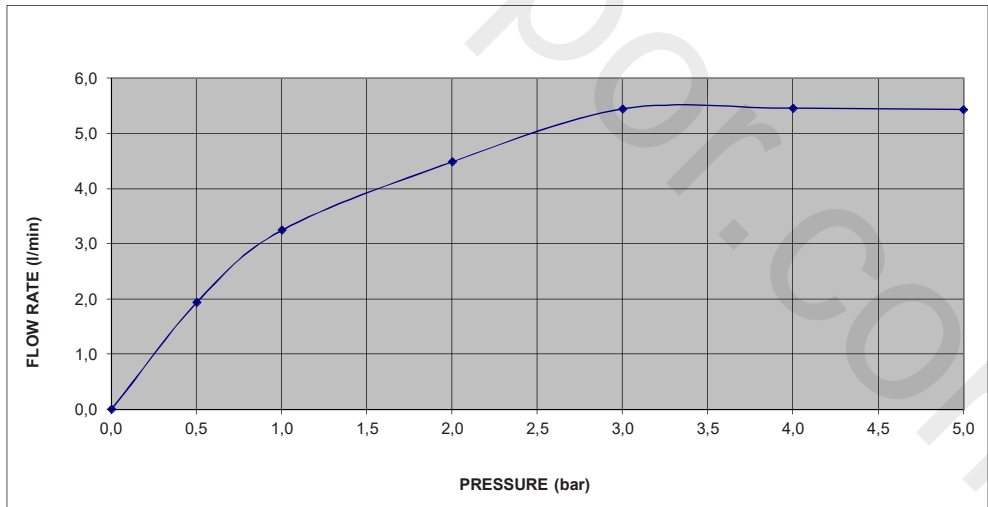

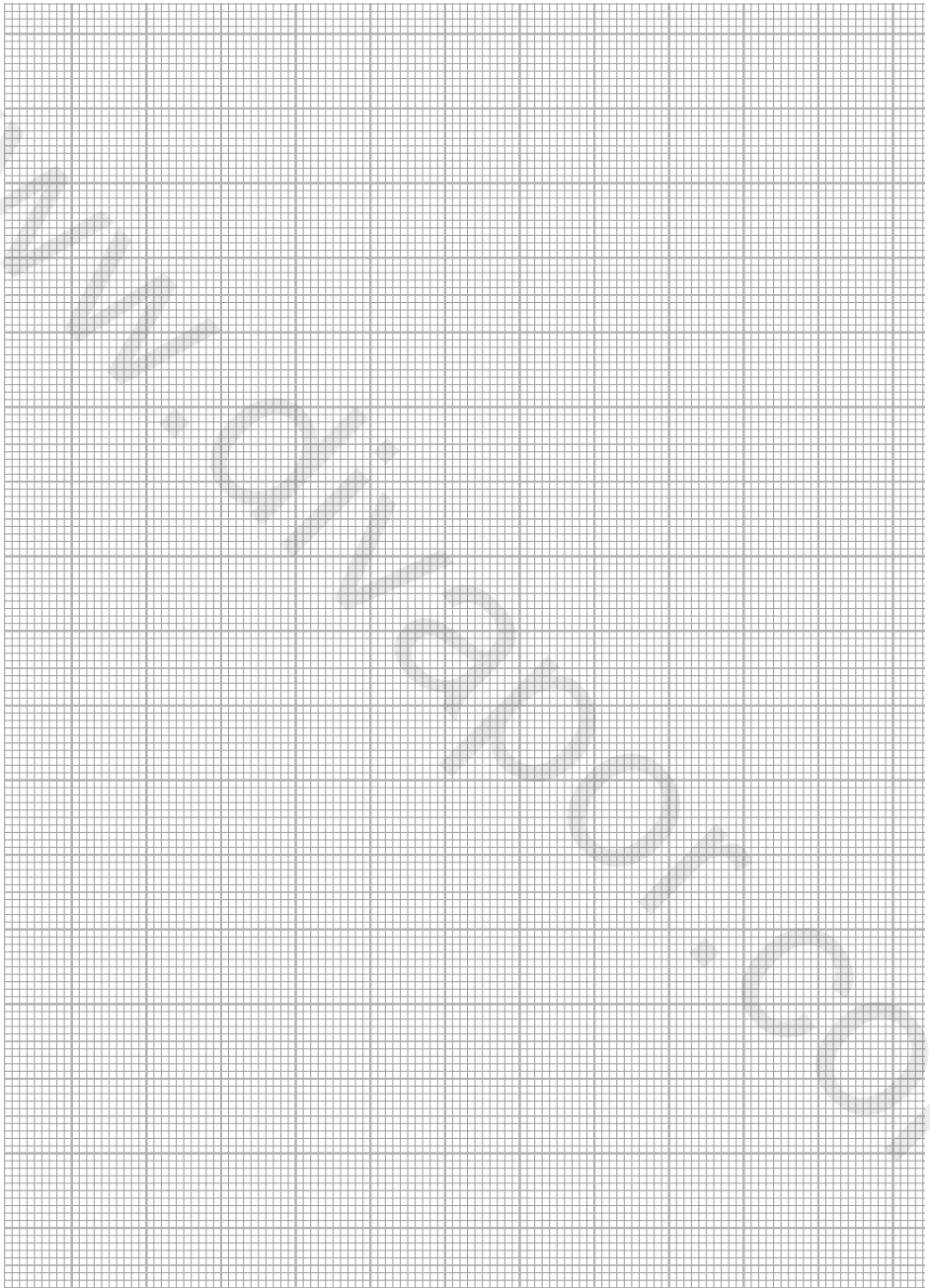

PORCELANOSA BATHROOMS



www.noken.com

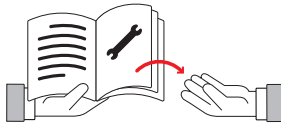

Para consultar la garantía u otra información relativa a este producto, visitar nuestra web:

For a warranty or other information on this product, visit our Web address:

Pour obtenir une garantie ou d'autres informations sur ce produit, visitez notre site web:

Para garantia ou outras informações sobre este produto, visite o nosso site:

Per consultare la garanzia o altre informazioni relative a questo prodotto, visitare il nostro sito Web:

Hinweise zur Garantie und zu sonstigen Einzelheiten zu dem Produkt finden Sie auf unserer Webseite:

Для получения гарантийной или другой информации, связанной с данным продуктом, посетите наш веб-сайт:

Aby zapoznać się z gwarancją lub innymi informacjami związanymi z danym produktem, odwiedź naszą stronę internetową:

关于这个产品的保修及其它信息，请访问我司的网站参看。

تنترنٹن إلی عان عقوم قرايزء اچرلء، جتن مل اذهب قوقل عتم یرخا تا مول عم یا وا قلا فکلا ءعجار مل