

AXOR

DE / Gebrauchsanleitung / Montageanleitung	02
FR / Mode d'emploi / Instructions de montage	03
EN / Instructions for use / assembly instructions	04
IT / Istruzioni per l'uso / Istruzioni per Installazione	05
ES / Modo de empleo / Instrucciones de montaje	06
NL / Gebruiksaanwijzing / Handleiding	07
DK / Brugsanvisning / Monteringsvejledning	08
PT / Instruções para uso / Manual de Instalação	09
PL / Instrukcja obsługi / Instrukcja montażu	10
CS / Návod k použití / Montážní návod	11
SK / Návod na použitie / Montážny návod	12
ZH / 用户手册 / 组装说明	13
RU / Руководство пользователя / Инструкция по монтажу	14
FI / Käyttöohje / Asennusohje	15
SV / Bruksanvisning / Monteringsanvisning	16
LT / Vartotojo instrukcija / Montavimo instrukcijos	17
HR / Upute za uporabu / Uputstva za instalaciju	18
TR / Kullanım kılavuzu / Montaj kılavuzu	19
RO / Manual de utilizare / Instrucțiuni de montare	20
EL / Οδηγίες χρήσης / Οδηγία συναρμολόγησης	21
SL / Navodilo za uporabo / Navodila za montažo	22
ET / Kasutusjuhend / Paigaldusjuhend	23
LV / Lietošanas pamācība / Montāžas instrukcija	24
SR / Uputstvo za upotrebu / Uputstvo za montažu	25
NO / Bruksanvisning / Montasjeveiledning	26
BG / Инструкция за употреба / Ръководство за монтаж	27
SQ / Udhëzuesi i përdorimit / Udhëzime rreth montimit	28
AR / دليل الاستخدام / تعليمات التجميع	29
HU / Használati útmutató / Szerelési útmutató	30

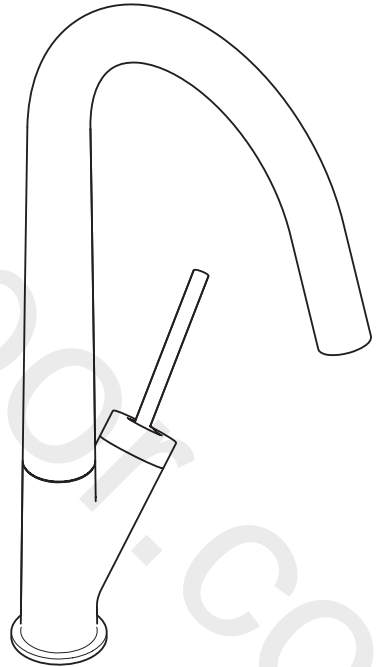

AXOR Starck
10822XXX

AXOR Starck Eco
12801000

△ SICHERHEITSHINWEISE

- △ Bei der Montage müssen zur Vermeidung von Quetsch- und Schnittverletzungen Handschuhe getragen werden.
- △ Große Druckunterschiede zwischen den Kalt- und Warmwasseranschlüssen müssen ausgeglichen werden.

MONTAGEHINWEISE

- / Vor der Montage muss das Produkt auf Transportschäden untersucht werden. Nach dem Einbau werden keine Transport- oder Oberflächenschäden anerkannt.
- / Die Leitungen und die Armatur müssen nach den gültigen Normen montiert, gespült und geprüft werden.
- / Die in den Ländern jeweils gültigen Installationsrichtlinien sind einzuhalten.
- / 12801000: Die Armatur kann nicht in Verbindung mit einem Durchlauferhitzer verwendet werden.

TECHNISCHE DATEN

Betriebsdruck: max. 1 MPa
 Empfohlener Betriebsdruck: 0,1 - 0,5 MPa
 Prüfdruck: 1,6 MPa

(1 MPa = 10 bar = 147 PSI)

Heißwassertemperatur: max. 70°C
 Empfohlene Heißwassertemperatur: 65°C
 Thermische Desinfektion: max. 70°C/4 min

Das Produkt ist ausschließlich für Trinkwasser konzipiert!

SYMBOLERKLÄRUNG

 Kein essigsäurehaltiges Silikon verwenden!

 MASSE (siehe Seite 37)

 DURCHFLUSSDIAGRAMM (siehe Seite 37)

 REINIGUNG (siehe Seite 38)

**SERVICETEILE** (siehe Seite 42)

XXX = Farbcodierung
 000 = Chrom
 020 = Polished Chrome
 130 = Polished Bronze
 140 = Brushed Bronze
 250 = Brushed Gold-Optic
 260 = Brushed Chrome
 300 = Polished Redgold
 310 = Brushed Redgold
 330 = Polished Black Chrome
 340 = Brushed Black Chrome
 800 = Stainless Steel Optic
 820 = Brushed Nickel
 830 = Polished Nickel
 930 = Polished Brass
 950 = Brushed Brass
 990 = Polished Gold-Optic

SONDERZUBEHÖR

(nicht im Lieferumfang enthalten)



Adapter (G $\frac{1}{2}$ /G $\frac{3}{4}$) #93395000 (siehe Seite 43)

**BEDIENUNG** (siehe Seite 36)

Hansgrohe empfiehlt, morgens oder nach längeren Stagnationszeiten den ersten halben Liter nicht als Trinkwasser zu verwenden.

**PRÜFZEICHEN** (siehe Seite 44)

STÖRUNG	URSACHE	ABHILFE
/ Wenig Wasser	/ Luftsprudler verkalkt, verschmutzt	/ Luftsprudler reinigen/austauschen
/ Armatur schwergängig	/ Kartusche defekt, verkalkt	/ Kartusche austauschen
/ Armatur tropft	/ Kartusche defekt	/ Kartusche austauschen
/ Wasseraustritt am Befestigungsschaft	/ Anschlusschläuche nicht ganz in den Grundkörper eingeschraubt	/ Anschlusschläuche von Hand festziehen
	/ O-Ring am Anschluss Schlauch defekt	/ O-Ring austauschen

△ CONSIGNES DE SÉCURITÉ

- △ Lors du montage, porter des gants de protection pour éviter toute blessure par écrasement ou coupure.
- △ Il est conseillé d'équilibrer les pressions de l'eau chaude et froide.

INSTRUCTIONS POUR LE MONTAGE

- / Avant son montage, s'assurer que le produit n'a subi aucun dommage pendant le transport. Après le montage, tout dommage de transport ou de surface ne pourra pas être reconnu.
- / Les conduites et la robinetterie doivent être montés, rincés et contrôlés selon les normes en vigueur.
- / Les directives d'installation en vigueur dans le pays concerné doivent être respectées.
- / 12801000: Le robinet ne fonctionne pas avec une production d'eau chaude instantanée.

INFORMATIONS TECHNIQUES

Pression de service autorisée:	max. 1 MPa
Pression de service conseillée:	0,1 - 0,5 MPa
Pression maximum de contrôle:	1,6 MPa (1 MPa = 10 bar = 147 PSI)
Température d'eau chaude:	max. 70°C
Température recommandée:	65°C
Désinfection thermique:	max. 70°C / 4 min

Le produit est exclusivement conçu pour de l'eau potable!

DESCRIPTION DU SYMBOLE



Ne pas utiliser de silicone contenant de l'acide acétique!



DIMENSIONS (voir pages 37)



DIAGRAMME DU DÉBIT
(voir pages 37)



NETTOYAGE (voir pages 38)



PIÈCES DÉTACHÉES (voir pages 42)

XXX = Couleurs
000 = Chromé
020 = Polished Chrome
130 = Polished Bronze
140 = Brushed Bronze
250 = Brushed Gold-Optic
260 = Brushed Chrome
300 = Polished Redgold
310 = Brushed Redgold
330 = Polished Black Chrome
340 = Brushed Black Chrome
800 = Stainless Steel Optic
820 = Brushed Nickel
830 = Polished Nickel
930 = Polished Brass
950 = Brushed Brass
990 = Polished Gold-Optic

ACCESSOIRES EN OPTION

(ne fait pas partie de la fourniture)



Adaptateur (G $\frac{1}{2}$ / G $\frac{3}{4}$) #93395000
(voir pages 43)



INSTRUCTIONS DE SERVICE
(voir pages 36)

Hansgrohe recommande de ne pas utiliser le premier demi-litre le matin ou après une période de stagnation prolongée.



CLASSIFICATION ACOUSTIQUE
ET DÉBIT (voir pages 44)

DYSFONCTIONNEMENT	ORIGINE	SOLUTION
/ Pas assez d'eau	/ aérateur entartré ou encrassé	/ Nettoyer l'aérateur ou le changer éventuellement
/ Dureté de fonctionnement	/ Cartouche défectueuse, entartrée	/ Changer la cartouche
/ Le mitigeur goutte	/ Cartouche défectueuse	/ Changer la cartouche
/ Fuite à la fixation sous le mitigeur	/ Les flexibles de raccordement ne sont pas correctement visser dans le corps. / Joint torique sous les flexible de raccor- dements défectueux	/ Resserer le flexible à la main. / Changer le joint torique

MONTAGE (voir pages 32) 

⚠ SAFETY NOTES

- ⚠ Gloves should be worn during installation to prevent crushing and cutting injuries.
- ⚠ The hot and cold supplies must be of equal pressures.

INSTALLATION INSTRUCTIONS

- / Prior to installation, inspect the product for transport damages. After it has been installed, no transport or surface damage will be honoured.
- / The pipes and the fixture must be installed, flushed and tested as per the applicable standards.
- / The plumbing codes applicable in the respective countries must be observed.
- / 12801000: The mixer can not used together with a continuous flow water heater.

TECHNICAL DATA

Operating pressure:	max. 1 MPa
Recommended operating pressure:	0,1 - 0,5 MPa
Test pressure:	1,6 MPa (1 MPa = 10 bar = 147 PSI)
Hot water temperature:	max. 70°C
Recommended hot water temp.:	65°C
Thermal disinfection:	max. 70°C / 4 min

The product is exclusively designed for drinking water!

SYMBOL DESCRIPTION



Do not use silicone containing acetic acid!



DIMENSIONS (see page 37)



FLOW DIAGRAM (see page 37)



CLEANING (see page 38)



SPARE PARTS (see page 42)

XXX = Colors

000 = Chrome Plated

020 = Polished Chrome
130 = Polished Bronze
140 = Brushed Bronze
250 = Brushed Gold-Optic
260 = Brushed Chrome
300 = Polished Redgold
310 = Brushed Redgold
330 = Polished Black Chrome
340 = Brushed Black Chrome
800 = Stainless Steel Optic
820 = Brushed Nickel
830 = Polished Nickel
930 = Polished Brass
950 = Brushed Brass
990 = Polished Gold-Optic

SPECIAL ACCESSORIES

(order as an extra)



Adapter (G $\frac{1}{2}$ /G $\frac{3}{4}$) #93395000 (see page 43)

OPERATION (see page 36)

Hansgrohe recommends not to use as drinking water the first half liter of water drawn in the morning or after a prolonged period of non-use.



TEST CERTIFICATE (see page 44)

FAULT	CAUSE	REMEDY
/ Insufficient water	/ Aerator calcified, dirty	/ Clean aerator, replace as necessary
/ Mixer stiff	/ Cartridge defective, calcified	/ Exchange cartridge
/ Mixer dripping	/ Cartridge defective	/ Exchange cartridge
/ Water escaping at the threaded base	/ connection hoses not completely screwed into basic body	/ Tighten connection hoses by hand
	/ O-ring at the connection hose defective.	/ Exchange O-ring



△ INDICAZIONI SULLA SICUREZZA

- △ Durante il montaggio, per evitare ferite da schiacciamento e da taglio bisogna indossare guanti protettivi.
- △ Attenzione! Compensare le differenze di pressione tra i collegamenti dell'acqua fredda e dell'acqua calda.





ISTRUZIONI PER IL MONTAGGIO

- / Prima del montaggio è necessario controllare che non ci siano stati danni durante il trasporto. Una volta eseguito il montaggio, non verranno riconosciuti eventuali danni di trasporto o delle superfici.
- / Montare, lavare e controllare tubature e rubinetteria rispettando le norme correnti.
- / Vanno rispettate le direttive di installazione nazionali vigenti nel rispettivo paese.
- / 12801000: Il rubinetto non può essere utilizzato insieme ad uno scald-acqua istantaneo.

DATI TECNICI

- Pressione d'uso: max. 1 MPa
 Pressione d'uso consigliata: 0,1 - 0,5 MPa
 Pressione di prova: 1,6 MPa
 (1 MPa = 10 bar = 147 PSI)
- Temperatura dell'acqua calda: max. 70°C
 Temp. dell'acqua calda consigliata: 65°C
 Disinfezione termica: max. 70°C / 4 min
- Il prodotto è concepito esclusivamente per acqua potabile!

DESCRIZIONE SIMBOLO

-  Non utilizzare silicone contenente acido acetico!
-  INGOMBRI (vedi pagg. 37)
-  DIAGRAMMA FLUSSO (vedi pagg. 37)
-  PULITURA (vedi pagg. 38)



PARTI DI RICAMBIO (vedi pagg. 42)

- XXX = Trattamento
- 000 = Cromato
- 020 = Polished Chrome
- 130 = Polished Bronze
- 140 = Brushed Bronze
- 250 = Brushed Gold-Optic
- 260 = Brushed Chrome
- 300 = Polished Redgold
- 310 = Brushed Redgold
- 330 = Polished Black Chrome
- 340 = Brushed Black Chrome
- 800 = Stainless Steel Optic
- 820 = Brushed Nickel
- 830 = Polished Nickel
- 930 = Polished Brass
- 950 = Brushed Brass
- 990 = Polished Gold-Optic

ACCESSORI SPECIALI

(non contenuto nel volume di fornitura)

Adattatore (G $\frac{1}{2}$ /G $\frac{3}{4}$) #93395000
(vedi pagg. 43)



PROCEDURA (vedi pagg. 36)

Hansgrohe raccomanda, di mattina oppure dopo lunghi tempi di stagnazione, di non utilizzare il primo mezzo litro come acqua potabile.



SEGNO DI VERIFICA (vedi pagg. 44)

PROBLEMA	POSSIBILE CAUSA	RIMEDIO
/ Scarsità d'acqua	/ Rompigetto difettosa, piena di calcare	/ Pulire oppure sostituire il rompigetto
/ Miscelatore duro	/ Cartuccia difettosa	/ Sostituire la cartuccia
/ Miscelatore gocciola	/ Cartuccia difettosa	/ Sostituire la cartuccia
/ Perdita di acqua al set di fissaggio	/ I raccordi dei flessibili avvitati male nel corpo incasso	/ Avvitare i raccordi flessibili a mano
	/ O-ring al raccordo flessibile difettoso	/ Sostituire l'o-ring



INDICACIONES DE SEGURIDAD

- ⚠ Durante el montaje deben utilizarse guantes para evitar heridas por aplastamiento o corte.
- ⚠ Grandes diferencias de presión en servicio entre agua fría y agua caliente deben equilibrarse.

INDICACIONES PARA EL MONTAJE

- / Antes del montaje se debe examinar el producto contra daños de transporte. Después de la instalación no se reconoce ningún daño de transporte o de superficie.
- / Los conductos y la grifería deben montarse, lavarse y comprobarse según las normas vigentes.
- / Es obligatorio el cumplimiento de las directrices de instalación vigentes en el país respectivo.
- / 12801000: Este grifo no es apto en combinación con un calentador continuo.

DATOS TÉCNICOS

Presión en servicio:	max. 1 MPa
Presión recomendada en servicio:	0,1 - 0,5 MPa
Presión de prueba:	1,6 MPa (1 MPa = 10 bar = 147 PSI)
Temperatura del agua caliente:	max. 70°C
Temp. recomendada del agua caliente:	65°C
Desinfección térmica:	max. 70°C / 4 min

El producto ha sido concebido exclusivamente para agua potable.

DESCRIPCIÓN DE SÍMBOLOS

 No utilizar silicona que contiene ácido acético!

 **DIMENSIONES** (ver página 37)

 **DIAGRAMA DE CIRCULACIÓN**
(ver página 37)

 **LIMPIAR** (ver página 38)

**REPUESTOS** (ver página 42)

XXX = Acabados
000 = Cromado
020 = Polished Chrome
130 = Polished Bronze
140 = Brushed Bronze
250 = Brushed Gold-Optic
260 = Brushed Chrome
300 = Polished Redgold
310 = Brushed Redgold
330 = Polished Black Chrome
340 = Brushed Black Chrome
800 = Stainless Steel Optic
820 = Brushed Nickel
830 = Polished Nickel
930 = Polished Brass
950 = Brushed Brass
990 = Polished Gold-Optic

O PCIONAL (no incluido en el suministro)

Adaptador (G $\frac{1}{2}$ /G $\frac{3}{4}$) #93395000
(ver página 43)

**MANEJO** (ver página 36)

Hansgrohe recomienda no utilizar el primer medio litro como agua potable por las mañanas o tras un largo periodo de inactividad.

**MARCA DE VERIFICACIÓN**
(ver página 44)

PROBLEMA	CAUSA	SOLUCIÓN
/ Sale poca agua	/ Aireador con cal o sucio	/ limpiar/cambiar aireador
/ Manecilla va dura	/ cartucho dañado	/ cambiar el cartucho
/ Grifo pierde agua	/ cartucho dañado	/ cambiar el cartucho
/ Pérdida de agua en el set de fijación	/ Conexión flexible mal atornillada al cuerpo del caño.	/ Apretar a mano la conexión flexible
	/ Daños en la junta de la conexión flexible	/ cambiar juntas

△ VEILIGHEIDSIINSTRUCTIES

- △ Bij de montage moeten ter voorkoming van knel- en snijwonden handschoenen worden gedragen.
- △ Grote drukverschillen tussen de koud- en warmwater-toevoer dienen vermeden te worden.

MONTAGE-INSTRUCTIES

- / Vóór de montage moet het product gecontroleerd worden op transportschade. Na de inbouw wordt geen transport- of oppervlakteschade meer aanvaard.
- / De leidingen en armaturen moeten gemonteerd, gespoeld en gecontroleerd worden volgens de geldige normen.
- / De in de overeenkomstige landen geldende installatierichtlijnen moeten nageleefd worden.
- / 12801000: Het artikel kan niet in combinatie met een doorstroomtoestel toegepast worden.

TECHNISCHE GEGEVENS

Werkdruk: max.	max. 1 MPa
Aanbevolen werkdruk:	0,1 - 0,5 MPa
Getest bij:	1,6 MPa
	(1 MPa = 10 bar = 147 PSI)
Temperatuur warm water:	max. 70°C
Aanbevolen warm water temp.:	65°C
Thermische desinfectie:	max. 70°C / 4 min
Het product is uitsluitend ontworpen voor drinkwater!	

SYMBOOLBESCHRIJVING

 Gebruik geen zuurhoudende siliconen!

 MATEN (zie blz. 37)

 DOORSTROOMDIAGRAM
(zie blz. 37)

 REINIGEN (zie blz. 38)



SERVICE ONDERDELEN (zie blz. 42)

XXX = Kleuren
000 = Verchroomd
020 = Polished Chrome
130 = Polished Bronze
140 = Brushed Bronze
250 = Brushed Gold-Optic
260 = Brushed Chrome
300 = Polished Redgold
310 = Brushed Redgold
330 = Polished Black Chrome
340 = Brushed Black Chrome
800 = Stainless Steel Optic
820 = Brushed Nickel
830 = Polished Nickel
930 = Polished Brass
950 = Brushed Brass
990 = Polished Gold-Optic

TOEBEHOREN

(behoort niet tot het leveringspakket)

Adapter (G $\frac{1}{2}$ /G $\frac{3}{4}$) #93395000 (zie blz. 43)

BEDIENING (zie blz. 36)

Hansgrohe raadt aan om 's morgens na langere stagnatietijden de eerste halve liter niet als drinkwater te gebruiken.

KEURMERK (zie blz. 44)



STORING

- / Weinig water
- / Bediening zwaar
- / Mengkraan lekt
- / Lekkage op montageschacht

OORZAAK

- / Perlator verstopt
- / Kardoes defect of verkalkt
- / Kardoes defect
- / Aansluitslangen niet geheel in kraan-
huis vastgedraaid
- / O-ring van aansluitlang defect

OPLOSSING

- / Perlator reinigen/ uitwisselen
- / Kardoes uitwisselen
- / Kardoes uitwisselen
- / Aansluitslangen handvast aandraaien
- / O-ring uitwisselen

MONTAGE (zie blz. 32)



△ SIKKERHEDSANVISNINGER

- △ Ved monteringen skal der bruges handsker for at undgå kvæstelser og snitsår.
- △ Større trykforskelle mellem koldt og varmt vand bør udjævnes.

MONTERINGSANVISNINGER

- / Før monteringen skal produktet kontrolleres for transportskader. Efter monteringen godkendes transportskader eller skader på overfladen ikke længere.
- / Ledningerne og armaturerne skal monteres, skylles og kontrolleres iht. de gældende standarder.
- / Installationsbestemmelserne, der gælder i det enkelte land, skal overholdes.
- / 12801000: Armaturet bør ikke anvendes i forbindelse med en gennemstrømningsvandvarmer.

TEKNISKE DATA

Driftstryk:	max. 1 MPa
Anbefalet driftstryk:	0,1 - 0,5 MPa
Prøvetryk:	1,6 MPa
	(1 MPa = 10 bar = 147 PSI)
Varmtvandstemperatur:	max. 70°C
Anbefalet varmtvandstemperatur:	65°C
Termisk desinfektion:	max. 70°C / 4 min
Produktet er udelukkende beregnet til drikkevand!	

SYMBOLBESKRIVELSE

 Der må ikke benyttes eddikesyreholdig silikone!

 MÅLENE (se s. 37)

 GENNEMSTRØMNINGSDIAGRAM (se s. 37)

 RENGØRING (se s. 38)



RESERVEDELE (se s. 42)

XXX	= Overflade
000	= Krom
020	= Polished Chrome
130	= Polished Bronze
140	= Brushed Bronze
250	= Brushed Gold-Optic
260	= Brushed Chrome
300	= Polished Redgold
310	= Brushed Redgold
330	= Polished Black Chrome
340	= Brushed Black Chrome
800	= Stainless Steel Optic
820	= Brushed Nickel
830	= Polished Nickel
930	= Polished Brass
950	= Brushed Brass
990	= Polished Gold-Optic

SPECIALTILBEHØR

(ikke med i leveringsomfang)

Adapter (G $\frac{1}{2}$ / G $\frac{3}{4}$) #93395000 (se s. 43)

BRUGSANVISNING (se s. 36)

Hansgrohe anbefaler at den første halve liter om morgenen eller efter længere stagneringstider ikke anvendes som drikkevand.

GODKENDELSE (se s. 44)



FEJL	ÅRSAG	HJÆLP
/ For lidt vand	/ Tilkaltet/snavset perlator	/ Rengør/udskift perlator
/ Grebet går trægt	/ Kartusche defekt, tilkaltet	/ Udkift kartusche
/ Armaturet drypper	/ Defekt kartusche	/ Udkift kartusche
/ Armaturet er utæt ved befæstelsesdele	/ Tilslutningsslangerne er ikke skruet korrekt op i armaturet.	/ Med håndkraft skures tilslutningsslanger strammere på.
	/ Defekt o-ring på tilslutningsslange	/ Udkift o-ring



△ AVISOS DE SEGURANÇA

- △ Durante a montagem devem ser utilizadas luvas de protecção, de modo a evitar ferimentos resultantes de entalamentos e de cortes.
- △ Grandes diferenças entre as pressões das águas quente e fria devem ser compensadas.

AVISOS DE MONTAGEM

- / Antes da montagem deve-se controlar o produto relativamente a danos de transporte. Após a montagem não são aceites quaisquer danos de transporte ou de superfície.
- / As tubagens e a torneira têm que ser montadas, enxaguadas e verificadas de acordo com as normas em vigor.
- / A prescrições de instalação válidas nos respetivos países devem ser respeitadas.
- / 12801000: A misturadora não pode ser utilizada com esquentadores instantâneos ou caldeira.

DADOS TÉCNICOS

Pressão de funcionamento:	max. 1 MPa
Pressão de func. recomendada:	0,1 - 0,5 MPa
Pressão testada:	1,6 MPa
	(1 MPa = 10 bar = 147 PSI)
Temperatura da água quente:	max. 70°C
Temp. água quente recomendada:	65°C
Desinfecção térmica:	max. 70°C / 4 min

Este produto foi única e exclusivamente concebido para água potável!

DESCRIÇÃO DO SÍMBOLO



Não utilizar silicone que contenha ácido acético!



MEDIDAS (ver página 37)



FLUXOGRAMA (ver página 37)



LIMPEZA (ver página 38)



PEÇAS DE SUBSTITUIÇÃO
(ver página 42)

XXX = Acabamentos
000 = Cromado
020 = Polished Chrome
130 = Polished Bronze
140 = Brushed Bronze
250 = Brushed Gold-Optic
260 = Brushed Chrome
300 = Polished Redgold
310 = Brushed Redgold
330 = Polished Black Chrome
340 = Brushed Black Chrome
800 = Stainless Steel Optic
820 = Brushed Nickel
830 = Polished Nickel
930 = Polished Brass
950 = Brushed Brass
990 = Polished Gold-Optic

ACESSÓRIOS ESPECIAIS

(não incluído no volume de fornecimento)



Adaptador (G $\frac{1}{2}$ /G $\frac{3}{4}$) #93395000
(ver página 43)



FUNCIONAMENTO (ver página 36)

A Hansgrohe recomenda a não utilização do primeiro meio litro de água, de manhã ou após longas paragens, para fins de consumo.



MARCA DE CONTROLO
(ver página 44)

FALHA	CAUSA	SOLUÇÃO
/ Água insuficiente	/ Emulsor sujo	/ Limpar/trocar o emulsor
/ Misturadora perra	/ Cartucho defeituoso, calcificado	/ Substituir o cartucho
/ Misturadora a pingar	/ Cartucho defeituoso	/ Substituir o cartucho
/ Perde água pela base rosçada	/ Tubos de ligação não estão completamente enroscados	/ Apertar os tubos de ligação à mão
	/ O-ring dos tubo de ligação defeituoso	/ Trocar o-ring

MONTAGEM (ver página 32)



△ WSKAZÓWKI BEZPIECZEŃSTWA

- △ Aby uniknąć zranień na skutek zgniecenia lub przecięcia, podczas montażu należy nosić rękawice ochronne.
- △ Znaczne różnice ciśnień na dopływach ciepłej i zimnej wody muszą zostać wyrównane.

WSKAZÓWKI MONTAŻOWE

- / Przed montażem należy skontrolować produkt pod kątem szkód transportowych. Po montażu nie widać żadnych szkód transportowych ani szkód na powierzchni.
- / Przewody i armatura muszą być montowane, płukane i kontrolowane według obowiązujących norm.
- / Należy przestrzegać wytycznych instalacyjnych obowiązujących w danym kraju.
- / 12801000: Armatura nie może współpracować z przepływowymi podgrzewaczami wody.

DANE TECHNICZNE

- Ciśnienie robocze: maks. 1 MPa
 Zalecane ciśnienie robocze: 0,1 - 0,5 MPa
 Ciśnienie próbne: 1,6 MPa
 (1 MPa = 10 bary = 147 PSI)
- Temperatura wody gorącej: maks. 70°C
 Zalecana temperatura wody gorącej: 65°C
 Dezynfekcja termiczna: maks. 70°C/4 min
- Produkt przeznaczony wyłącznie do wody pitnej!

OPIS SYMBOLU



Nie stosować silikonów zawierających kwas octowy!



WYMIARY (patrz strona 37)



SCHEMAT PRZEPŁYWU
(patrz strona 37)



CZYSZCZENIE (patrz strona 38)



CZĘŚCI SERWISOWE
(patrz strona 42)

- XXX = Kody kolorów
 000 = Chrom
 020 = Polished Chrome
 130 = Polished Bronze
 140 = Brushed Bronze
 250 = Brushed Gold-Optic
 260 = Brushed Chrome
 300 = Polished Redgold
 310 = Brushed Redgold
 330 = Polished Black Chrome
 340 = Brushed Black Chrome
 800 = Stainless Steel Optic
 820 = Brushed Nickel
 830 = Polished Nickel
 930 = Polished Brass
 950 = Brushed Brass
 990 = Polished Gold-Optic

WYPOSAŻENIE SPECJALNE
(Nie jest częścią dostawy)



Prześciówka (G $\frac{1}{2}$ /G $\frac{3}{4}$) #93395000
(patrz strona 43)



OBSŁUGA (patrz strona 36)

Hansgrohe zaleca, by z rana lub po dłuższym czasie niekorzystania, pierwsze pół litra wody nie używać jako wody pitnej.



ZNAK JAKOŚCI (patrz strona 44)

USTERKA

/ Mała ilość wody

PRZYCZYNA

/ Napowietrzacz zakamieniony, zabrudzony

POMOC

/ Oczyszczyć/ wymienić napowietrzacz

/ Uchwyt armatury pracuje z wysiłkiem

/ Uszkodzony wkład, zakamieniony

/ Wymiana wkładu

/ Armatura cieknie

/ Uszkodzony wkład

/ Wymiana wkładu

/ Wyciek wody przy mocowaniu od dołu

/ Zbyt słabo wkręcone wężyki w korpus
 / Uszkodzony o-ring przy wężu przyłączeniowym

/ Dokręcić wężyki

/ Wymienić o-ring



△ BEZPEČNOSTNÍ POKYNY

- △ Pro zabránění řezným zraněním a pohmožděninám je nutné při montáži nosit rukavice.
- △ Je nutné vyrovnat velké rozdíly tlaku mezi přípoji studené a teplé vody.

POKYNY K MONTÁŽI





- / Před montáží je třeba produkt zkontrolovat, zda nebyl při transportu poškozen. Po zabudování nebudou uznány žádné škody způsobené transportem nebo poškození povrchu.
- / Vedení a armatura musí být namontovány, propláchnuty a otestovány podle platných norem.
- / Je třeba dodržovat montážní pravidla platné v dané zemi.
- / 12801000: Armatura se nesmí používat v kombinaci s průtokovým ohřivačem.

TECHNICKÉ ÚDAJE

Provozní tlak:	max. 1 MPa
Doporučený provozní tlak:	0,1 - 0,5 MPa
Zkušební tlak:	1,6 MPa (1 MPa = 10 bar = 147 PSI)
Teplota horké vody:	max. 70°C
Doporučená teplota horké vody:	65°C
Teplná desinfekce:	max. 70°C / 4 min

Výrobky Hansgrohe jsou vhodné pro přímý kontakt s pitnou vodou.

POPIS SYMBOLŮ

-  Nepoužívat silikon s obsahem kyseliny octové!
-  ROZMĚRY (viz strana 37)
-  DIAGRAM PRŮTOKU (viz strana 37)
-  ČIŠTĚNÍ (viz strana 38)



SERVISNÍ DÍLY (viz strana 42)

XXX	= Kód povrchové úpravy
000	= Chrom
020	= Polished Chrome
130	= Polished Bronze
140	= Brushed Bronze
250	= Brushed Gold-Optic
260	= Brushed Chrome
300	= Polished Redgold
310	= Brushed Redgold
330	= Polished Black Chrome
340	= Brushed Black Chrome
800	= Stainless Steel Optic
820	= Brushed Nickel
830	= Polished Nickel
930	= Polished Brass
950	= Brushed Brass
990	= Polished Gold-Optic

ZVLÁŠTNÍ PŘÍSLUŠENSTVÍ

(není součástí dodávky)

Adaptér (G $\frac{1}{2}$ / G $\frac{3}{4}$) #93395000 (viz strana 43)

OVLÁDÁNÍ (viz strana 36)

Hansgrohe doporučuje ráno nebo po delších přestávkách nepoužívat prvního půl litru jako pitnou vodu.

ZKUŠEBNÍ ZNAČKA (viz strana 44)



PORUCHA	PŘÍČINA	ODSTRANĚNÍ
/ Málo vody	/ perláro zanesen vodním kamenem, znečištěn	/ vyčistit/vyměnit perlátor
/ Armatura jde ztěžka	/ Kartuše je vadná, zanesená vodním kamenem	/ Kartuši vyměnit
/ Armatura odkapává	/ Kartuše je vadná	/ Kartuši vyměnit
/ výstup vody na upevňovacím násadci	/ přípojovací hadice nejsou dostatečně zašroubovány do tělesa	/ přípojovací hadice utáhnout rukou
	/ O-kroužek na přípojovací hadici je defektní	/ vyměnit O-kroužek

△ BEZPEČNOSTNÉ POKYNY

- △ Pri montáži musíte nosiť rukavice, aby ste predišli pomliaždeninám a rezným poraneniam.
- △ Veľké rozdiely v tlaku medzi prípojkami studenej a teplej vody musia byť vyrovnané.

POKYNY PRE MONTÁŽ

- / Pred montážou musíte produkt skontrolovať, či nebol počas transportu poškodený. Po zabudovaní nebudú uznané žiadne škody spôsobené transportom alebo poškodenia povrchu.
- / Ledningarna och blandaren måste monteras, spolansigenom och kontrolleras enligt de gällande normerna.
- / Je potrebné dodržiavať smernice o inštalácii, ktoré sú práve teraz platné v krajinách.
- / 12801000: Armatúra sa nesmie používať v kombinácii s prietokovým ohrievačom.

TECHNICKÉ ÚDAJE

Prevádzkový tlak:	max. 1 MPa
Doporučený prevádzkový tlak:	0,1 - 0,5 MPa
Skúšobný tlak:	1,6 MPa
	(1 MPa = 10 bar = 147 PSI)

Teplota teplej vody:	max. 70°C
Doporučená teplota teplej vody:	65°C
Termická dezinfekcia:	max. 70°C / 4 min

Výrobok je koncipovaný výhradne pre pitnú vodu!

POPIS SYMBOLOV

 Nepoužívať silikón s obsahom kyseliny octovej!

 ROZMERY (viď strana 37)

 DIAGRAM PRIETOKU (viď strana 37)

 ČISTENIE (viď strana 38)



SERVISNÉ DIELY (viď strana 42)

XXX	= Farebné označenie
000	= Chróm
020	= Polished Chrome
130	= Polished Bronze
140	= Brushed Bronze
250	= Brushed Gold-Optic
260	= Brushed Chrome
300	= Polished Redgold
310	= Brushed Redgold
330	= Polished Black Chrome
340	= Brushed Black Chrome
800	= Stainless Steel Optic
820	= Brushed Nickel
830	= Polished Nickel
930	= Polished Brass
950	= Brushed Brass
990	= Polished Gold-Optic

ZVLÁŠTNE PRÍSLUŠENSTVO

(nie je súčasťou dodávky)



Adaptér (G¹/₂ / G³/₄) #93395000 (viď strana 43)



OBSLUHA (viď strana 36)

Hansgrohe odporúča ráno a po dlhších dobách odstávky nepoužiť prvého pol litra vody ako pitnú vodu.



OSVEDČENIE O SKÚŠKE (viď strana 44)

PORUCHA	PRÍČINA	POMOC
/ Málo vody	/ Perlátor zanesený vodným kameňom	/ Vyčistiť alebo vymeniť perlátor
/ Armatúra "chodí" ťažko	/ Kartuša je poškodená, vápenaté usadeniny	/ Vymeniť kartušu
/ Z armatúry kvapká voda	/ Kartuša je poškodená	/ Vymeniť kartušu
/ Uhajanie vode ob prítldilnem nastavku	/ Hadice pripojenia nie sú celkom zaskrutkované do základného telesa	/ Hadice pripojenia dotiahnuť ručne
	/ Chýbný O krúžok na pripojovacej hadici	/ Vymeniť O krúžok



△ 安全技巧

- △ 装配时为避免挤压和切割受伤，必须戴上手套。
- △ 冷热水管间过大的压力差必须予以平衡。

安装提示

- / 安装前必须检查产品是否受到运输损害。安装后将不认可运输损害或表面损伤。
- / 管道和阀门必须根据通用标准进行安装、冲洗和检查。
- / 请遵守当地国家现行的安装规定。
- / 12801000: 阀门不可与即热式热水器连接使用。

技术参数

工作压力:	最大 1 MPa
推荐工作压力:	0,1 - 0,5 MPa
测试压强:	1,6 MPa (1 MPa = 10 bar = 147 PSI)
热水温度:	最大 70°C
推荐热水温度:	65°C
热力消毒:	最大 70°C / 4 分钟

该产品专为饮用水设计！

符号说明

-  请勿使用含有乙酸的硅胶！
-  大小 (参见第页 37)
-  流量示意图 (参见第页 37)
-  清洗 (参见第页 38)
-  备用零件 (参见第页 42)
- XXX = 颜色代码
- 000 = 镀铬
- 020 = Polished Chrome
- 130 = Polished Bronze
- 140 = Brushed Bronze
- 250 = Brushed Gold-Optic
- 260 = Brushed Chrome

- 300 = Polished Redgold
- 310 = Brushed Redgold
- 330 = Polished Black Chrome
- 340 = Brushed Black Chrome
- 800 = Stainless Steel Optic
- 820 = Brushed Nickel
- 830 = Polished Nickel
- 930 = Polished Brass
- 950 = Brushed Brass
- 990 = Polished Gold-Optic

选装附件 (不在供货范围内)



转接器 (G $\frac{1}{2}$ /G $\frac{3}{4}$) #93395000
(参见第页 43)



操作 (参见第页 36)

汉斯格雅建议，清晨或在水流长时间停滞
后，前半升水不作饮用水使用。



检验标记 (参见第页 44)

问题	原因	补救
/ 龙头出水量小	/ 通风机结垢，脏污	/ 检查通风机，视需要更换
/ 龙头不灵活	/ 阀芯损坏，结垢	/ 更换阀芯
/ 龙头滴水	/ 阀芯损坏	/ 更换阀芯
/ 水从螺纹底座中流出	/ 连接软管没有完全旋入基体	/ 用手拧紧连接软管
	/ 连接软管的○形环损坏	/ 更换○形环

△ УКАЗАНИЯ ПО ТЕХНИКЕ БЕЗОПАСНОСТИ

- △ Во время монтажа следует надеть перчатки во избежание прищемления и порезов.
- △ донного клапа. Перед установкой смесителя необходимо регулировочными кранами выровнять давление холодной и горячей воды при помощи вентилей регулирующих подачу воды в квартиру.

УКАЗАНИЯ ПО МОНТАЖУ

- / Перед монтажом следует проверить изделие на предмет повреждений при перевозке. После монтажа претензии о возмещении ущерба за повреждения при перевозке или повреждения поверхностей не принимаются.
- / Трубы и арматура должны быть установлены, промыты и проверены в соответствии с действующими нормами.
- / Необходимо соблюдать требования по монтажу, действующие в соответствующих странах.
- / 12801000: Применение арматуры при наличии проточного нагревателя не допускается.

ТЕХНИЧЕСКИЕ ДАННЫЕ

Рабочее давление:	не более. 1 МПа
Рекомендуемое рабочее давление:	0,1 - 0,5 МПа
Давление:	1,6 МПа (1 МПа = 10 bar = 147 PSI)
Температура горячей воды:	не более. 70°C
Рекомендуемая темп. гор. воды:	65°C
Термическая дезинфекция:	не более. 70°C/4 мин

Изделие предназначено исключительно для питьевой воды!

ОПИСАНИЕ СИМВОЛОВ



Не применяйте силикон, содержащий искусственную кислоту.



РАЗМЕРЫ (см. стр. 37)



СХЕМА ПОТОКА (см. стр. 37)



ОЧИСТКА (см. стр. 38)



КОМПЛЕКТ (см. стр. 42)

XXX	= Цветная кодировка
000	= Хром
020	= Polished Chrome
130	= Polished Bronze
140	= Brushed Bronze
250	= Brushed Gold-Optic
260	= Brushed Chrome
300	= Polished Redgold
310	= Brushed Redgold
330	= Polished Black Chrome
340	= Brushed Black Chrome
800	= Stainless Steel Optic
820	= Brushed Nickel
830	= Polished Nickel
930	= Polished Brass
950	= Brushed Brass
990	= Polished Gold-Optic

СПЕЦИАЛЬНЫЕ ПРИНАДЛЕЖНОСТИ (не включено в объем поставки!)



Переходник (G1/2 / G3/4) #93395000
(см. стр. 43)



ЭКСПЛУАТАЦИЯ (см. стр. 36)

Hansgrohe рекомендует по утрам либо после длительного перерыва в использовании не использовать первые поллитра воды для питья.



ЗНАК ТЕХНИЧЕСКОГО КОНТРОЛЯ (см. стр. 44)

НЕИСПРАВНОСТЬ	ПРИЧИНА	УСТРАНЕНИЕ НЕИСПРАВНОСТИ
/ недостаточный давление (если устан напор воды)	/ Аэратор засорен накипью, загрязнен	/ Очистите/замените аэратор
/ Арматура работает с усилием	/ Картридж неисправен, засорение накипью	/ Замените картридж
/ Арматура протекает	/ Картридж неисправен	/ Замените картридж
/ Выход воды у основания крепления	/ Шланги подключения не полностью завернуты в корпус	/ Затяните шланги подключения вручную
	/ Уплотнительное кольцо круглого сечения на соединительном шланге не исправно	/ Замените уплотнительное кольцо круглого сечения



△ TURVALLISUUSOHJEET

- △ Asennuksessa on käytettävä käsitteitä puristumien ja viiltojen aiheuttamien tapaturmien estämiseksi.
- △ Suuret paine-erot kylmä- ja kuumavesiliitännöiden välillä on tasattava.

A SENNUSOHJEET

- / Ennen asennusta on tarkastettava tuotteen mahdolliset kuljetusvahingot. Asennuksen jälkeen kuljetus- ja pintavaurioita ei hyväksytä.
- / Putket ja hana on asennettava, huuhdeltava ja tarkastettava voimassa olevien standardien mukaisesti.
- / Jokaisessa maassa on noudatettava siellä päteviä asennusohjeita.
- / 12801000: Armaturia ei voi käyttää lämpimän veden-kuumentimen yhteydessä.

TEKNISET TIEDOT

Käyttöpaine:	maks. 1 MPa
Suosittelua käyttöpaine:	0,1 - 0,5 MPa
Koestuspaine:	1,6 MPa (1 MPa = 10 bar = 147 PSI)
Kuuman veden lämpötila:	maks. 70°C
Kuuman veden suosituslämpötila:	65°C
Lämpödesinfektio:	maks. 70°C/4 min

Tuote on suunniteltu käytettäväksi ainoastaan juomaveden kanssa!

MERKIN KUVAUS

 Älä käytä etikkahappopitoista silikonia!

 MITAT (katso sivu 37)

 VIRTAUSDIAGRAMMI
(katso sivu 37)

 PUHDISTUS (katso sivu 38)



VARAOSAT (katso sivu 42)

XXX = Värikoodaus
000 = Kromi
020 = Polished Chrome
130 = Polished Bronze
140 = Brushed Bronze
250 = Brushed Gold-Optic
260 = Brushed Chrome
300 = Polished Redgold
310 = Brushed Redgold
330 = Polished Black Chrome
340 = Brushed Black Chrome
800 = Stainless Steel Optic
820 = Brushed Nickel
830 = Polished Nickel
930 = Polished Brass
950 = Brushed Brass
990 = Polished Gold-Optic

ERITYISVARUSTE (ei kuulu toimitukseen)

Sovitin (G $\frac{1}{2}$ /G $\frac{3}{4}$) #93395000 (katso sivu 43)



KÄYTTÖ (katso sivu 36)

Hansgrohe suosittelee, että ensimmäistä puolta litraa ei käytetä juomavetenä aamuisin eikä silloin, kun laitetta ei ole käytetty pitkään aikaan.



KOESTUSMERKKI (katso sivu 44)

HÄIRIÖ	SYY	TOIMENPIDE
/ Vähän vettä	/ Poresuutin kalkkeutunut, likaantunut	/ Puhdista / vaihda poresuutin
/ Hana on raskaskäyttöinen	/ Patruuna rikki, kalkkikerrostumia	/ Vaihda patruuna
/ Hanasta tippuu vettä	/ Patruuna rikki	/ Vaihda patruuna
/ Vettä valuu kiinnityskauluksesta	/ Liitosletkut eivät ole kierretty kiinni perusrunkoon pohjaan asti	/ Kierrä liitosletkut kiinni käsikireytyen
	/ Liitosletkun O-renkas on rikki	/ Vaihda O-renkas

A SENNUS (katso sivu 32)



△ SÄKERHETSANVISNINGAR

- △ Handskar ska bäras under monteringsarbetet så att man kan undvika kläm- och skärskador.
- △ Stora tryckskillnader mellan anslutningarna för varmt och kallt vatten måste utjämnas.

MONTERINGSANVISNINGAR

- / Det måste undersökas om produkten har transportskador innan den monteras. Efter monteringen accepteras inga transport- eller ytskiktsskador.
- / Ledningarna och blandaren måste monteras, spolas igenom och kontrolleras enligt de gällande normerna.
- / De installationsriktlinjer som gäller i länderna ska följas.
- / 12801000: Blandaren kan inte användas tillsammans med en varmvattenberedare.

TEKNISKA DATA

Drifttryck:	max. 1 MPa
Rek. drifttryck:	0,1 - 0,5 MPa
Tryck vid provtryckning:	1,6 MPa
	(1 MPa = 10 bar = 147 PSI)
Varmvattentemperatur:	max. 70°C
Rek. varmvattentemp.:	65°C
Termisk desinfektion:	max. 70°C / 4 min

Produkten är enbart avsedd för dricksvatten!



020 = Polished Chrome
130 = Polished Bronze
140 = Brushed Bronze
250 = Brushed Gold-Optic
260 = Brushed Chrome
300 = Polished Redgold
310 = Brushed Redgold
330 = Polished Black Chrome
340 = Brushed Black Chrome
800 = Stainless Steel Optic
820 = Brushed Nickel
830 = Polished Nickel
930 = Polished Brass
950 = Brushed Brass
990 = Polished Gold-Optic

SPECIALTILLBEHÖR

(medföljer ej leveransen)

Adapter (G $\frac{1}{2}$ /G $\frac{3}{4}$) #93395000 (se sidan 43)

HANTERING (se sidan 36)

Hansgrohe rekommenderar att den första halvlitern inte används som dricksvatten på morgonen eller efter längre perioder utan användning.

TESTSIGILL (se sidan 44)



SYMBOLFÖRKLARING

 Använd inte silikon som innehåller ättiksyra!

 MÅTTEN (se sidan 37)

 FLÖDESSCHEMA (se sidan 37)

 RENGÖRING (se sidan 38)

 RESERVDELAR (se sidan 42)

XXX = Färgkodning

000 = Krom

STÖRNING	ORSAK	ÅTGÄRD
/ För lite vatten	/ Areator är täckt av kalk, smutsig	/ Rengör/byt areator
/ Blandare är trög	/ Patron defekt, förkalkad	/ Byt ut patron
/ Blandare droppar	/ Patron defekt	/ Byt ut patron
/ Vatten kommer ut vid monteringsstaget	/ Anslutningsslangar inte helt inskruvade i grundkonstruktionen	/ Drag fast anslutningsslangar för hand.
	/ O-ring på anslutningsslang defekt	/ Byt ut O-ring

MONTERING (se sidan 32)



△ SAUGUMO TECHNIKOS NURODYMAI

- △ Apsaugai nuo užspaudimo ir įsijovimo montavimo metu mūvėkite pirštines.
- △ Turi būti išlyginti šalto ir karšto slėgio nelygumai.

MONTAVIMO INSTRUKCIJA

- / Prieš montuojant būtina patikrinti, ar gaminys nebuvo pažeistas transportavimo metu. Sumontavus pretenzijos dėl transportavimo ir paviršiaus pažeidimų nepriimamos.
- / Vamzdžiai ir sujungimai turi būti montuojami, plaunami ir tikrinami pagal galiojančias normas.
- / Laikykitės atitinkamoje šalyje galiojančių direktyvų dėl įrengimo.
- / 12801000: Armatūros negalima naudoti kartu su tekančio vandens šildytuvu.

TECHNINIAI DUOMENYS

- Darbinis slėgis: ne daugiau kaip 1 MPa
 Rekomenduojamas slėgis: 0,1 - 0,5 MPa
 Bandomasis slėgis: 1,6 MPa
 (1 MPa = 10 barų = 147 PSI)
- Karšto vandens temperatūra: ne daugiau kaip 70°C
 Rekomenduojama karšto vandens temperatūra: 65°C
 Terminis dezinfekavimas: ne daugiau kaip 70°C / 4 min
- Produktas skirtas tik geriamajam vandeniui!

SIMBOLIO APRAŠYMAS



Nenaudokite silikono, kurio sudėtyje yra acto rūgšties!



IŠMATAVIMAI (žr. psl. 37)



PRALAUDUMO DIAGRAMA
(žr. psl. 37)



VALYMAS (žr. psl. 38)



ATSARGINĖS DALYS (žr. psl. 42)

- XXX = Spalvos
 000 = Chrom
 020 = Polished Chrome
 130 = Polished Bronze
 140 = Brushed Bronze
 250 = Brushed Gold-Optic
 260 = Brushed Chrome
 300 = Polished Redgold
 310 = Brushed Redgold
 330 = Polished Black Chrome
 340 = Brushed Black Chrome
 800 = Stainless Steel Optic
 820 = Brushed Nickel
 830 = Polished Nickel
 930 = Polished Brass
 950 = Brushed Brass
 990 = Polished Gold-Optic

SPECIALŪS PRIEDAI (nėra pridedama)



Adapteris (G $\frac{1}{2}$ /G $\frac{3}{4}$) #93395000 (žr. psl. 43)

EKSPLOATACIJA (žr. psl. 36)

Naudojant po ilgesnės pertraukos, „Hansgrohe“ rekomenduoja pirmo pusės litro vandens nevertoti kaip geriamojo.



BANDYMO PAŽYMA (žr. psl. 44)

GEDIMAS

- / Per maža srovė
- / Sunkiai sukiojama rankenėlė
- / Maišytuvus praleidžia vandenį
- / Prateka vanduo per tvirtinimo kotą

PRIEŽASTIS

- / Perlatorius apkalkėjęs, užsikimšęs
- / Kasetė pažeista, užkalkėjusi
- / Kasetė pažeista
- / Prijungimo žarnos nepilnai įsuktos į korpusą
- / Pajungimo žarnos tarpinė pažeista

PRIEMONĖ

- / Perlatorių išvalyti/pakeisti
- / Pakeisti kasetę
- / Pakeisti kasetę
- / Prijungimo žarnas prisukti ranka
- / tarpinę pakeisti

MONTAVIMAS (žr. psl. 32)



△ SIGURNOSNE UPUTE

- △ Prilikom montaže se radi sprječavanja prignječenja i posjekotina moraju nositi rukavice.
- △ Velika razlika u pritisku između vruće i hladne vode mora biti izbalansirana.

UPUTE ZA MONTAŽU

- / Prije montaže mora se provjeriti je li proizvod oštećen prilikom transporta. Nakon ugradnje se ne priznaju nikakve reklamacije koje se odnose na površinska i transportna oštećenja.
- / Cijevi i armatura moraju biti postavljeni, isprani i testirani prema važećim normama.
- / Obvezno se moraju uvažiti propisi o instalacijama koji vrijede u dotičnoj zemlji.
- / 12801000: Armatura se ne može rabiti u kombinaciji sa protočnim bojlerom.

TEHNIČKI PODATCI

Najveći dopušteni tlak:	tlak 1 MPa
Preporučeni tlak:	0,1 - 0,5 MPa
Probni tlak:	1,6 MPa (1 MPa = 10 bar = 147 PSI)
Temperatura vruće vode:	tlak 70°C
Preporučena temperatura vruće vode:	65°C
Termička dezinfekcija:	tlak 70°C / 4 min

Proizvod je koncipiran isključivo za pitku vodu!

OPIS SIMBOLA



Nemojte koristiti silikon koji sadrži octenu kiselinu!



MJERE (pogledaj stranicu 37)



DIJAGRAM PROTOKA
(pogledaj stranicu 37)



ČIŠĆENJE (pogledaj stranicu 38)



REZERVNI DJELOVI

(pogledaj stranicu 42)

XXX = Boje
000 = Krom
020 = Polished Chrome
130 = Polished Bronze
140 = Brushed Bronze
250 = Brushed Gold-Optic
260 = Brushed Chrome
300 = Polished Redgold
310 = Brushed Redgold
330 = Polished Black Chrome
340 = Brushed Black Chrome
800 = Stainless Steel Optic
820 = Brushed Nickel
830 = Polished Nickel
930 = Polished Brass
950 = Brushed Brass
990 = Polished Gold-Optic

POSEBNI PRIBOR

(Nije sadržano u isporuci!)



Prilagodnik (G $\frac{1}{2}$ /G $\frac{3}{4}$) #93395000
(pogledaj stranicu 43)



UPOTREBA (pogledaj stranicu 36)

Hansgrohe preporuča da ujutro ili nakon duljeg nekorištenja prvih 1/2 litre vode ne upotrebljavate za piće.



OZNAKA TESTIRANJA

(pogledaj stranicu 44)

GREŠKA

/ Nedovoljno vode

/ Ručica se zaglavila

/ Slavina kaplje

/ Voda izlazi na dijelu gdje je slavina učvršćena

UZROK

/ Aerator je začepljen naslagama kamenca ili prljav

/ Neispravan uložak Taloženje kamenca

/ Neispravan uložak

/ Priključna crijeva nisu potpuno učvršćena na tijelo

/ O-prsteni priključnih crijeva su neispravni

OTKLANJANJE

/ Očistite ili zamijenite aerator.

/ Zamijenite uložak

/ Zamijenite uložak

/ Priključna crijeva učvrstite rukom

/ Zamijenite O-prsten



△ GÜVENLİK UYARILARI

- △ Montaj esnasında ezilme ve kesilme gibi yaralanmaları önlemek için eldiven kullanılmalıdır.
- △ Sıcak ve soğuk su bağlantıları arasında büyük basınç farklılıkları varsa, bu basınç farklılıklarının dengelenmesi gerekir.

MONTAJ AÇIKLAMALARI

- / Montaj işleminden önce ürün nakliye hasarları yönünden kontrol edilmelidir. Montaj işleminden sonra nakliye veya yüzey hasarları için sorumluluk üstlenilmemektedir.
- / Boruların ve armatürün montajı, yıkanması ve kontrolü geçerli normlara göre yapılmalıdır.
- / Ülkelerde geçerli kurulum yönetmeliklerine riayet edilmelidir.
- / 12801000: Armatür bir akış ısıtıcısı ile birlikte kullanılabilir.

TEKNİK BİLGİLER

İşletme basıncı: azami 1 MPa
Tavsiye edilen işletme basıncı: 0,1 - 0,5 MPa
Kontrol basıncı: 1,6 MPa

(1 MPa = 10 bar = 147 PSI)

Sıcak su sıcaklığı: azami 70°C
Tavsiye edilen su ısı: 65°C
Termik dezenfeksiyon: azami 70°C/4 dak

Ürün sadece şebeke suyu için tasarlanmıştır!

SİMGE AÇIKLAMASI

 Asetik asit içeren silikon kullanmayın!

 ÖLÇÜLERİ (bakınız sayfa 37)

 AKIŞ DİYAGRAMI (bakınız sayfa 37)

 TEMİZLEME (bakınız sayfa 38)



YEDEK PARÇALAR (bakınız sayfa 42)

XXX = Renkler
000 = Krom
020 = Polished Chrome
130 = Polished Bronze
140 = Brushed Bronze
250 = Brushed Gold-Optic
260 = Brushed Chrome
300 = Polished Redgold
310 = Brushed Redgold
330 = Polished Black Chrome
340 = Brushed Black Chrome
800 = Stainless Steel Optic
820 = Brushed Nickel
830 = Polished Nickel
930 = Polished Brass
950 = Brushed Brass
990 = Polished Gold-Optic

ÖZEL AKSESUARLAR

(Teslimat kapsamına dahil değildir)



Adaptör (G¹/₂ / G³/₄) #93395000
(bakınız sayfa 43)



KULLANIMI (bakınız sayfa 36)

Hansgrohe sabahları uzun durgunluk süresi sonrasında ilk yarım litre suyun içme suyu olarak kullanılmamasını önerir.



KONTROL İŞARETİ (bakınız sayfa 44)

ARIZA	SEBEP	YARDIM
/ Az su geliyor	/ Perlatör kireçlenmiş, kirlenmiş	/ Perlatör kireçlenmiş, kirlenmiş
/ Batarya kullanımı ağırlaşıyor	/ Kartuş Bozulmuş ve kireçlenmiş olabilir	/ Kartuşu değiştirin
/ Batarya su damlatıyor	/ Kartuş bozuk olabilir	/ Kartuşu değiştirin
/ Sabitleme kutusundan su çıkışı	/ Bağlantı hortumları ana gövdeye tamamen vidalanmamış	/ Bağlantı hortumlarını elinizle sıkın
	/ Bağlantı hortumundaki O-ring arızalı	/ O-ringi değiştirin

MONTAJ I (bakınız sayfa 32)



△ INSTRUȚIUNI DE SIGURANȚĂ

- △ La montare utilizați mănuși pentru evitarea contuziunilor și tăierii mâinilor.
- △ Diferențele de presiune mari între alimentarea cu apă rece și apă caldă trebuie echilibrate.

INSTRUCȚIUNI DE MONTARE

- / Înainte de instalare verificați, dacă produsul prezintă deteriorări de transport. După instalare garanția nu acoperă deteriorările de transport și cele de suprafață.
- / Conductele și bateriile trebuie montate, spălate și verificate conform normelor în vigoare.
- / Respectați reglementările referitoare la instalare valabile în țara respectivă.
- / 12801000: Bateria nu poate fi utilizată în combinație cu un boiler în flux continuu.

DATE TEHNICE

- Presiune de funcționare: max. 1 MPa
 Presiune de funcționare recomandată: 0,1 - 0,5 MPa
 Presiune de verificare: 1,6 MPa
 (1 MPa = 10 bar = 147 PSI)
- Temperatura apei calde: max. 70°C
 Temperatura recomandată a apei calde: 65°C
 Dezinfecție termică: max. 70°C / 4 min
- Produsul este destinat exclusiv pentru apă potabilă.

DESCRIEREA SIMBOLURILOR

 Nu utilizați silicon cu conținut de acid acetic!

 DIMENSIUNI (vezi pag. 37)

 DIAGRAMA DE DEBIT
(vezi pag. 37)

 CURĂȚARE (vezi pag. 38)



PIESE DE SCHIMB (vezi pag. 42)

- XXX = Coduri de culori
 000 = Crom
 020 = Polished Chrome
 130 = Polished Bronze
 140 = Brushed Bronze
 250 = Brushed Gold-Optic
 260 = Brushed Chrome
 300 = Polished Redgold
 310 = Brushed Redgold
 330 = Polished Black Chrome
 340 = Brushed Black Chrome
 800 = Stainless Steel Optic
 820 = Brushed Nickel
 830 = Polished Nickel
 930 = Polished Brass
 950 = Brushed Brass
 990 = Polished Gold-Optic

ACCESORII OPȚIONALE

(nu este inclus în setul livrat)

Adaptor (G¹/₂ / G³/₄) #93395000 (vezi pag. 43)



UTILIZARE (vezi pag. 36)

Hansgrohe vă recomandă, ca dimineața sau după perioade mai lungi de pauză să nu folosiți prima jumătate de litru de apă pentru băut.



CERTIFICAT DE TESTARE (vezi pag. 44)

DERANJAMENT	CAUZA	MĂSURI DE REMEDIERE
/ Prea puțină apă	/ Depunerii de calcar și impurități pe pulverizatorul de aer.	/ Curățați / schimbați pulverizatorul de aer.
/ Bateria se mișcă dificil	/ Cartuș defect din cauza depunerilor de calcar	/ Schimbați cartușul.
/ Bateria picură	/ Cartuș defect	/ Schimbați cartușul.
/ Scurgere de apă la șaftul de fixare.	/ Furtunurile de racordare nu sunt bine înșurubate în corpul bateriei.	/ Strângeți cu mâna furtunurile de racordare.
	/ Inelul O de la furtunul de racord defect	/ Schimbați inelul O.

MONTARE (vezi pag. 32)



ΔΥΠΟΔΕΙΞΕΙΣ ΑΣΦΑΛΕΙΑΣ

- Δ Για να αποφύγετε τραυματισμούς κατά τη συναρμολόγηση πρέπει να φοράτε γάντια.
- Δ Οι διαφορές της πίεσης μεταξύ της σύνδεσης κρύου και ζεστού νερού θα πρέπει να αντισταθμίζονται.

ΟΔΗΓΙΕΣ ΣΥΝΑΡΜΟΛΟΓΗΣΗΣ

- / Πριν τη συναρμολόγηση πρέπει να εξεταστεί το προϊόν για ζημιές μεταφοράς. Μετά την εγκατάσταση δεν αναγνωρίζονται ζημιές από τη μεταφορά ή επιφανειακές ζημιές.
- / Οι σωλήνες και η μπαταρία πρέπει να τοποθετηθούν σύμφωνα με τα ισχύοντα πρότυπα, να τεθούν υπό πίεση και να δοκιμαστούν.
- / Θα πρέπει να τηρούνται οι οδηγίες εγκατάστασης που ισχύουν σε κάθε κράτος.
- / 12801000: Η μπαταρία δεν μπορεί να χρησιμοποιηθεί σε συνδυασμό με ταχυθερμοσίφωνα.

ΤΕΧΝΙΚΑ ΧΑΡΑΚΤΗΡΙΣΤΙΚΑ

- Λειτουργία πίεσης: έως 1 MPa
 Συνιστώμενη λειτουργία πίεσης: 0,1 - 0,5 MPa
 Πίεση ελέγχου: 1,6 MPa
 (1 MPa = 10 bar = 147 PSI)
- Θερμοκρασία ζεστού νερού: έως 70°C
 Συνιστώμενη θερμοκρασία ζεστού νερού: 65°C
 Θερμική απολύμανση: έως 70°C / 4 min
- Το προϊόν έχει σχεδιαστεί αποκλειστικά για πόσιμο νερό!

ΠΕΡΙΓΡΑΦΗ ΣΥΜΒΟΛΩΝ



Μην χρησιμοποιείτε σιλικόνη που περιέχει οξικό οξύ!



ΔΙΑΣΤΑΣΕΙΣ (βλ. Σελίδα 37)



ΔΙΑΓΡΑΜΜΑ ΡΟΗΣ (βλ. Σελίδα 37)



ΚΑΘΑΡΙΣΜΟΣ (βλ. Σελίδα 38)



ΑΝΤΑΛΛΑΚΤΙΚΑ (βλ. Σελίδα 42)

- XXX = Χρώματα
 000 = Επιχρωμιωμένο
 020 = Polished Chrome
 130 = Polished Bronze
 140 = Brushed Bronze
 250 = Brushed Gold-Optic
 260 = Brushed Chrome
 300 = Polished Redgold
 310 = Brushed Redgold
 330 = Polished Black Chrome
 340 = Brushed Black Chrome
 800 = Stainless Steel Optic
 820 = Brushed Nickel
 830 = Polished Nickel
 930 = Polished Brass
 950 = Brushed Brass
 990 = Polished Gold-Optic

ΕΙΔΙΚΑ ΑΞΕΣΟΥΡΑ (δεν περιλαμβάνεται στον παραδοτέο εξοπλισμό)



Προσαρμογές (G^{1/2} / G^{3/4}) #93395000 (βλ. Σελίδα 43)



ΧΕΙΡΙΣΜΟΣ (βλ. Σελίδα 36)

Η Hansgrohe συνιστά το πρωί ή μετά από μεγάλα χρονικά διαστήματα αχρησίας να μην χρησιμοποιείτε το πρώτο μισό λίτρο νερό σαν πόσιμο.



ΣΗΜΑ ΕΛΕΓΧΟΥ (βλ. Σελίδα 44)

ΒΛΑΒΗ

- / Ανεπαρκές νερό
- / Σκληρή μπαταρία (μείκτης)
- / Η μπαταρία στάζει
- / Διαρροή νερού στον άξονα στερέωσης

ΑΙΤΙΑ

- / Άλατα και βρωμιά στο φίλτρο
- / Ελαττωματικό φυσιγγίο, άλατα
- / Ελαττωματικό φυσιγγίο
- / Οι σωλήνες σύνδεσης δεν είναι πλήρως βιδωμένοι στο βασικό κορμό
- / Ο στρογγυλός δακτύλιος στο σωλήνα σύνδεσης είναι ελαττωματικός

ΔΙΟΡΘΩΣΗ

- / Καθαρίστε/αλλάξτε το φίλτρο
- / Αλλαγή φυσιγγίου
- / Αλλαγή φυσιγγίου
- / Σφίξτε τους σωλήνες σύνδεσης με το χέρι
- / Αλλάξτε το στρογγυλό δακτύλιο

ΣΥΝΑΡΜΟΛΟΓΗΣΗ (βλ. Σελίδα 32)



△ VARNOSTNA OPOZORILA

- △ Pri montaži je treba nositi rokavice, da se preprečijo poškodbe zaradi zmečkanja ali urezov.
- △ Velike razlike v tlaku med priključkom za mrzlo in priključkom za toplo vodo je potrebno izravnati.

NAVODILA ZA MONTAŽO

- / Pred montažo je treba izdelek preveriti glede morebitnih transportnih poškodb. Po vgradnji transportne ali površinske poškodbe ne bodo več priznane.
- / Cevi in armaturo je treba montirati, izprati in preveriti po veljavnih standardih.
- / Upoštevati je treba pravilnike o inštalacijah, ki veljajo v posamezni državi.
- / 12801000: Armature ni možno uporabiti v povezavi s pretočnim grelnikom.

TEHNIČNI PODATKI

Delovni tlak:	maks. 1 MPa
Priporočeni delovni tlak:	0,1 - 0,5 MPa
Preskusni tlak:	1,6 MPa
	(1 MPa = 10 bar = 147 PSI)
Temperatura tople vode:	maks. 70°C
Priporočena temperatura tople vode:	65°C
Termična dezinfekcija:	maks. 70°C/4 min
Proizvod je zasnovan izključno za sanitarno vodo!	

OPIS SIMBOLA



Ne smete uporabiti silikona, ki vsebuje ocetno kislino!



MERE (glejte stran 37)



DIAGRAM PRETOKA
(glejte stran 37)



ČIŠČENJE (glejte stran 38)



REZERVNI DELI (glejte stran 42)

XXX = Barve
000 = Krom
020 = Polished Chrome
130 = Polished Bronze
140 = Brushed Bronze
250 = Brushed Gold-Optic
260 = Brushed Chrome
300 = Polished Redgold
310 = Brushed Redgold
330 = Polished Black Chrome
340 = Brushed Black Chrome
800 = Stainless Steel Optic
820 = Brushed Nickel
830 = Polished Nickel
930 = Polished Brass
950 = Brushed Brass
990 = Polished Gold-Optic

POSEBEN PRIBOR (Ni vključeno)



Adapter (G $\frac{1}{2}$ /G $\frac{3}{4}$) #93395000
(glejte stran 43)



UPRAVLJANJE (glejte stran 36)

Hansgrohe priporoča, da zjutraj ali po daljšem času stagnacije prvega pol litra vode ne uporabite kot pitno vodo.



PREKUSNI ZNAK (glejte stran 44)

NAPAKA	VZROK	POMOČ
/ Malo vode	/ Perlator poapnen; umazan	/ Očistite/zamenjajte perlator
/ Težko premikanje armature	/ Pokvarjen vložek, poapneno	/ Zamenjajte vložek
/ Iz armature kaplja	/ Pokvarjen vložek	/ Zamenjajte vložek
/ Uhajanje vode ob pritrdilnem nastavku	/ Priključne cevi niso popolnoma privijačene v osnovno ogrodje	/ Ročno zatisnite priključne cevi
	/ Obročna tesnila priključnih gibkih cevi so pokvarjena	/ Zamenjajte obročno tesnilo

MONTAŽA (glejte stran 32)



△ OHUTUSJUHISED

- △ Kandke paigaldamisel muljumis- ja löikevigastuste vältimiseks kindaid.
- △ Kui külma ja kuuma vee ühenduste surve on väga erinev, tuleb need tasakaalustada.





PAIGALDAMISJUHISED

- / Enne paigaldamist tuleb toodet kontrollida transpordikahjustuste osas. Pärast paigaldamist ei tunnustata enam transpordi- või pinnakahjustuste kaebuseid.
- / Voolikute ja segisti paigaldamisel, loputamisel ja kontrollimisel tuleb lähtuda kehtivatest normatiividest.
- / Vastavas riigis kehtivaid paigalduseeskirju tuleb järgida.
- / 12801000: Segistit ei saa kasutada koos läbivooluveesoojendiga.

TEHNILISED ANDMED

Töörõhk	maks. 1 MPa
Soovitav töörõhk:	0,1 - 0,5 MPa
Kontrollsurve:	1,6 MPa (1 MPa = 10 baari = 147 PSI)
Kuuma vee temperatuur:	maks. 70°C
Soovitav kuuma vee temperatuur:	65°C
Terminline desinfektsioon:	maks. 70°C/4 min
Toode on ette nähtud eranditult joogivee jaoks!	

SÜMBOLITE KIRJELDUS

-  Ärge kasutage äädikhapet sisaldavat silikooni!
-  MÕÕTUDE (vt lk 37)
-  LÄBIVOOLUDIAGRAMM (vt lk 37)
-  PUHASTAMINE (vt lk 38)



VARUOSAD (vt lk 42)

XXX	= Värvid
000	= Kroom
020	= Polished Chrome
130	= Polished Bronze
140	= Brushed Bronze
250	= Brushed Gold-Optic
260	= Brushed Chrome
300	= Polished Redgold
310	= Brushed Redgold
330	= Polished Black Chrome
340	= Brushed Black Chrome
800	= Stainless Steel Optic
820	= Brushed Nickel
830	= Polished Nickel
930	= Polished Brass
950	= Brushed Brass
990	= Polished Gold-Optic

SPETSIAALNE LISAVARUSTUS

(ei sisaldu komplektis)

Adapter (G $\frac{1}{2}$ /G $\frac{3}{4}$) #93395000 (vt lk 43)



KASUTAMINE (vt lk 36)

Hansgrohe soovib mitte kasutada esimest poolt liitrit hommikuti või pärast pikemat seisakuaega joogiveena.



KONTROLLSERTIFIKAAT (vt lk 44)

RIKE

- / Vähe vett
- / Segisti käib raskelt
- / Segisti tilgub
- / Veeleke kinnituse juures

PÕHJUS

- / Sõel on lupjunud, must
- / Tööelement on katkine, lubjastunud
- / Tööelement on katkine
- / Ühendusvoolikud ei ole korralikult põhi- / korpuse külge kruvitud
- / Ühendusvoolikute O-rõngastihendid katki

LAHENDUS

- / Puhastage segisti sõel vajadusel vahetage
- / Vahetage tööelement
- / Vahetage tööelement
- / Kruvige ühendusvoolikud käega kinni
- / Vahetage O-rõngastihend

PAIGALDAMINE (vt lk 32)



△ DROŠĪBAS NORĀDES

- △ Montāžas laikā, lai izvairītos no saspiedumiem un iegriezumiem, nepieciešams nēsāt cimdus.
- △ Jāizlīdzina spiediena atšķirības starp aukstā un karstā ūdens pievadiem.

NORĀDĪJUMI MONTĀŽAI

- / Pirms montāžas nepieciešams pārbaudīt, vai produktam transportēšanas laikā nav radušies bojājumi. Pēc iebūvēšanas bojājumi, kas radušies transportēšanas laikā, vai virsmas bojājumi netiek atzīti.
- / Caurulvadi un armatūra ir jāuzstāda, jāizskalo un jāpārbauda saskaņā ar spēkā esošajiem standartiem.
- / Jāievēro attiecīgās valsts spēkā esošās montāžas prasības.
- / 12801000: Armatūru nevar izmantot kopā ar caurplūdes sildītāju.

TEHNISKIE DATI

- Darba spiediens: maks. 1 MPa
 Ieteicamais darba spiediens: 0,1 - 0,5 MPa
 Pārbaudes spiediens: 1,6 MPa
 (1 MPa = 10 bar = 147 PSI)
- Karstā ūdens temperatūra: maks. 70°C
 Ieteicamā karstā ūdens temperatūra: 65°C
 Termiskā dezinfekcija: maks. 70°C / 4 min
- Izstrādājums ir paredzēts tikai dzeramajam ūdenim!

SIMBOLU NOZĪME

 Neizmantot silikonu, kas satur etiķskābi!

 IZMĒRUS (skat. lpp. 37)

 CAURPLŪDES DIAGRAMMA (skat. lpp. 37)

 TĪRĪŠANA (skat. lpp. 38)



REZERVES DAĻAS (skat. lpp. 42)

- XXX = Krāsu kodi
 000 = Hroma
 020 = Polished Chrome
 130 = Polished Bronze
 140 = Brushed Bronze
 250 = Brushed Gold-Optic
 260 = Brushed Chrome
 300 = Polished Redgold
 310 = Brushed Redgold
 330 = Polished Black Chrome
 340 = Brushed Black Chrome
 800 = Stainless Steel Optic
 820 = Brushed Nickel
 830 = Polished Nickel
 930 = Polished Brass
 950 = Brushed Brass
 990 = Polished Gold-Optic

SPECIĀLI AKSESUĀRI

(komplektā netiek piegādāts)



Adapteris (G¹/₂ / G³/₄) #93395000
 (skat. lpp. 43)



LĪETOŠANA (skat. lpp. 36)

Hansgrohe iesaka no rīta vai pēc ilgākiem pārtraukumiem nelietot pirmo puslitru ūdens dzeršanai.



PĀRBAUDES ZĪME (skat. lpp. 44)

TRAUCĒJUMS

IEMESLS

BOJĀJUMU NOVĒRŠANA

- | | | |
|------------------------------------|--|---|
| / Maz ūdens | / Aerators aizkaļķojies, aizsērējis | / Tīrīt / nomainīt aeratoru |
| / Jaucējkrāns smagi grozāms | / Bojāta kartuša, aizkaļķojusies | / Nomainīt kartušu |
| / Jaucējkrāns pil | / Bojāta kartuša | / Nomainīt kartušu |
| / Ūdens noplūde pie nostiprinājuma | / Pieslēguma šļūtenes nav līdz galam ieskrūvētas pamatelementā | / Pieslēguma šļūtenes ar roku pievilkt stingrāk |
| | / Bojāti pieslēguma šļūtenju O-gredzeni | / Nomainīt O-gredzenu |

MONTĀŽA (skat. lpp. 32)



△ SIGURNOSNE NAPOMENE

- △ Prilikom montaže se radi sprečavanja prignječenja i posekotina moraju nositi rukavice.
- △ Velika razlika u pritisku između vruće i hladne vode mora biti izbalansirana.

INSTRUKCIJE ZA MONTAŽU

- / Pre montaže se mora proveriti da li je proizvod oštećen pri transportu. Nakon ugradnje se ne priznaju nikakve reklamacije koje se odnose na površinska i transportna oštećenja.
- / Vodovi i armatura moraju biti postavljeni, isprani i testirani prema važećim normama.
- / Treba se pridržavati propisa koji u određenim zemljama važe za instalacije.
- / 12801000: Armatura se ne može upotrebljavati u kombinaciji sa protočnim bojlerom.

TEHNIČKI PODACI

Radni pritisak:	maks. 1 MPa
Preporučeni radni pritisak:	0,1 - 0,5 MPa
Probni pritisak:	1,6 MPa
	(1 MPa = 10 bar = 147 PSI)
Temperatura vruće vode:	maks. 70°C
Preporučena temperatura vruće vode:	65°C
Termička dezinfekcija:	maks. 70°C / 4 min
Proizvod je koncipiran isključivo za pijaću vodu!	

OPIS SIMBOLA



Nemojte koristiti silikon koji sadrži siričetu kiselinu!



MERE (vidi stranu 37)



DIJAGRAM PROTOKA
(vidi stranu 37)



ČIŠĆENJE (vidi stranu 38)



REZERVNI DELOVI (vidi stranu 42)

XXX = Oznake boja
000 = Hrom
020 = Polished Chrome
130 = Polished Bronze
140 = Brushed Bronze
250 = Brushed Gold-Optic
260 = Brushed Chrome
300 = Polished Redgold
310 = Brushed Redgold
330 = Polished Black Chrome
340 = Brushed Black Chrome
800 = Stainless Steel Optic
820 = Brushed Nickel
830 = Polished Nickel
930 = Polished Brass
950 = Brushed Brass
990 = Polished Gold-Optic

POSEBAN PRIBOR

(Nije sadržano u isporuci)



Adapter (G $\frac{1}{2}$ / G $\frac{3}{4}$) #93395000
(vidi stranu 43)



RUKOVANJE (vidi stranu 36)

Hansgrohe preporučuje da ujutru ili nakon dužeg nekorisćenja prvih pola litre vode ne koristite za piće.



ISPITNI ZNAK (vidi stranu 44)

SMETNJA

/ Nedovoljno vode

UZROK

/ Aerator je začepljen naslagama kamenca ili prljav

POMOĆ

/ Očistite ili zamenite aerator

/ Ručica se zaglavila

/ Neispravna kartuša, nataloženi kamenac

/ Zamenite kartušu

/ Slavina kaplje

/ Neispravna kartuša

/ Zamenite kartušu

/ Voda izlazi na delu gde je slavina učvršćena

/ Priključna creva nisu potpuno učvršćena na telo

/ Priključna creva učvrstite rukom

/ O prstenovi priključnih creva su neispravni

/ Zamenite O prsten



△ SIKKERHETSHENVISNINGER

- △ Bruk hansker under montasjonen for å unngå klem- og kuttskader.
- △ Store trykkdifferanser mellom kaldt- og varmtvannstilkoblinger skal utlignes.

MONTAGEHENVISNINGER

- / Før montasjonen skal produktet sjekkes for transportskader. Etter monteringen aksepteres ikke noen transport- eller overflateskader.
- / Ledningene og armaturen skal monteres, spyles og sjekkes iht. de gyldige normer.
- / Gjeldende retningslinjer for rørleggerarbeid i de enkelte land skal følges.
- / 12801000: Armaturen kan ikke brukes i forbindelse med en gjennomstrømningsvannvarmer.

TEKNISKE DATA

Driftstrykk	maks. 1 MPa
Anbefalt driftstrykk:	0,1 - 0,5 MPa
Prøvetrykk	1,6 MPa
	(1 MPa = 10 bar = 147 PSI)
Varmtvannstemperatur	maks. 70°C
Anbefalt temperatur for varmt vann	65°C
Termisk desinfisering:	maks. 70°C/4 min
Produktet er utelukkende designet for drikkevann!	

SYMBOLBESKRIVELSE



Ikke bruk silikon som inneholder eddiksyre!



MÅL (se side 37)



GJENNOMSTRØMNINGSDIAGRAM
(se side 37)



RENGJØRING (se side 38)



SERVICEDELER (se side 42)

XXX = Fargekode
000 = Krom
020 = Polished Chrome
130 = Polished Bronze
140 = Brushed Bronze
250 = Brushed Gold-Optic
260 = Brushed Chrome
300 = Polished Redgold
310 = Brushed Redgold
330 = Polished Black Chrome
340 = Brushed Black Chrome
800 = Stainless Steel Optic
820 = Brushed Nickel
830 = Polished Nickel
930 = Polished Brass
950 = Brushed Brass
990 = Polished Gold-Optic

EKSTRATILBEHØR

(ikke med i leveransen)



Adapter (G $\frac{1}{2}$ /G $\frac{3}{4}$) #93395000 (se side 43)

BETJENING (se side 36)

Om morgen og etter lengre stagnasjonstider anbefaler Hansgrohe å ikke bruke den første halvliteren som drikkevann.



PRØVEMERKE (se side 44)

FEIL	ÅRSAK	FEILRETTELSE
/ Lite vann	/ Luftsprudler forkalket, skitten	/ Luftsprudler rengjøres/byttes
/ Armatur ikke lett bevegelig	/ Kartusj defekt, forkalkning	/ Kartusj byttes
/ Armatur drypper	/ Kartusj defekt	/ Kartusj byttes
/ Vannlekkasje på festeskaft	/ Tilkoblingslanger ikke skrudd helt inn i baselement	/ Tilkoblingslanger trekkes fast fra hånd
	/ O-ring på tilkoblingslanger defekt	/ O-ring byttes



△ УКАЗАНИЯ ЗА БЕЗОПАСНОСТ

- △ При монтажа трябва да се носят ръкавици, за да се избегнат наранявания поради притискане или порязване.
- △ Големите разлики в налягането между изводите за студената и топлата вода трябва да се изравняват.

УКАЗАНИЯ ЗА МОНТАЖ

- / Преди монтажа продуктът трябва да се провери за транспортни щети. След монтажа не се признават транспортни или повърхностни щети.
- / Тръбопроводите и арматурата трябва да се монтират, промият и проверят в съответствие с валидните норми.
- / Трябва да бъдат спазвани валидните в съответните страни предписания за инсталиране.
- / 12801000: Арматурата не може да се използва във връзка с проточен нагревател.

ТЕХНИЧЕСКИ ДАННИ

Работно налягане:	макс. 1 МПа
Препоръчително работно налягане:	0,1 - 0,5 МПа
Контролно налягане:	1,6 МПа
	(1 МПа = 10 bar = 147 PSI)
Температура на горещата вода:	макс. 70°C
Препоръчителна температура на горещата вода:	65°C
Термична дезинфекция:	макс. 70°C / 4 мин
Продуктът е разработен само за питейна вода!	

ОПИСАНИЕ НА СИМВОЛИТЕ

 Не използвайте силикон, съдържащ оцветна киселина!

 РАЗМЕРИ (вижте стр. 37)

 ДИАГРАМА НА ПОТОКА (вижте стр. 37)

 ПОЧИСТВАНЕ (вижте стр. 38)

 СЕРВИЗНИ ЧАСТИ (вижте стр. 42)

XXX = Цветово кодиране
000 = Хром
020 = Polished Chrome
130 = Polished Bronze
140 = Brushed Bronze
250 = Brushed Gold-Optic
260 = Brushed Chrome
300 = Polished Redgold
310 = Brushed Redgold
330 = Polished Black Chrome
340 = Brushed Black Chrome
800 = Stainless Steel Optic
820 = Brushed Nickel
830 = Polished Nickel
930 = Polished Brass
950 = Brushed Brass
990 = Polished Gold-Optic

СПЕЦИАЛНИ ПРИНАДЛЕЖНОСТИ (не се съдържа в обема на доставка)

Адаптер (G $\frac{1}{2}$ /G $\frac{3}{4}$) #93395000 (вижте стр. 43)

 ОБСЛУЖВАНЕ (вижте стр. 36)

Hansgrohe препоръчва, сутрин и след по-продължително спиране първият половин литър да не се използва като питейна вода.

 КОНТРОЛЕН ЗНАК (вижте стр. 44)

НЕИЗПРАВНОСТ	ПРИЧИНА	ПОМОЩ
/ Малко вода	/ Аераторът е покрит с варовик, замърсен	/ Почистете/сменете аератора
/ Трудно подвижна арматура	/ Дефектна гилза, покрита с варовик	/ Сменете гилзата
/ Арматурата капе	/ Дефектна гилза	/ Сменете гилзата
/ Избиване на вода от закрепващата шийка	/ Свързващите маркучи не са напълно завинтени в основното тяло	/ Затегнете на ръка свързващите маркучи
	/ Дефектен О-образен пръстен на свързващия маркуч	/ Смяна на О-образен пръстен

МОНТАЖ (вижте стр. 32) 

△ UDHËZIME SIGURIE

- △ Për të evituar lëndimet e pickimeve ose të prerjeve gjatë procesit të montimit duhet që të vishni doreza.
- △ Ndryshimet e mëdha të presionit mes lidhjeve të ujit të ftohtë dhe atij të ngrohtë duhen ekuilibruar.

UDHËZIME PËR MONTIMIN

- / Përpara montimit duhet që produkti të kontrollohet për dëmtime nga transporti. Pas instalimit nuk do të njihet asnjë dëmtim nga transporti ose dëmtim i sipërfaqes.
- / Tubacionet dhe rubinetet duhet që të montohen, të shpëlahen dhe të kontrollohen sipas standardeve në fuqi
- / Duhet të respektohen linjat udhëzuese të instalimit, të vlefshme për vendet respektive.
- / 12801000: Armatura nuk mund të përdoret në kombinim me një ngrohës elektrik të ujit.

TË DHËNA TEKNIKE

Presioni gjatë punës	maks. 1 MPa
Presioni i rekomanduar:	0,1 - 0,5 MPa
Presioni për provë:	1,6 MPa
	(1 MPa = 10 bar = 147 PSI)
Temperatura e ujit të ngrohtë	maks. 70°C
Temperatura e rekomanduar e ujit të ngrohtë:	65°C
Dezinfektim Termik:	maks. 70°C / 4 min
Produkti është projektuar ekskluzivisht për ujë të pijshëm!	

PËRSHKRIMI I SIMBOLIT



Mos përdorni silikon që në përbërje ka acid acetik.



PËRMASAT (shih faqen 37)



DIAGRAMI I QARKULLIMIT
(shih faqen 37)



PASTRIMI (shih faqen 38)



PJESËT E SERVISIT (shih faqen 42)

XXX	= Kodimi me anë të ngjyrave
000	= Krom
020	= Polished Chrome
130	= Polished Bronze
140	= Brushed Bronze
250	= Brushed Gold-Optic
260	= Brushed Chrome
300	= Polished Redgold
310	= Brushed Redgold
330	= Polished Black Chrome
340	= Brushed Black Chrome
800	= Stainless Steel Optic
820	= Brushed Nickel
830	= Polished Nickel
930	= Polished Brass
950	= Brushed Brass
990	= Polished Gold-Optic

PAJISJE TË POSAÇME

(nuk përfshihet në vëllimin e furnizimit)



Përshtatësi (G¹/₂/G³/₄) #93395000
(shih faqen 43)



PËRDORIMI (shih faqen 36)

Hansgrohe rekomandon që në mëngjes ose pas periudhave të gjata që gjysmë litri i parë mos të pihet



SHENJA E KONTROLLIT
(shih faqen 44)

DEMTIM

- / Pak ujë
- / Armatura punon rende
- / Armatura pikon
- / Dalje e ujit në cilindrin fiksues

SHKAKU

- / Shperndaresi i ajrit me kalk, me papastërti
- / Kartusha me defekt, me kalk
- / Kartusha me defekt
- / Tubat e lidhjes jo komplet të vidhosur në karkasen baze
- / Unaza O tek tubi lidhës me defekt

NDIHME

- / Pastroni shperndaresin e ajrit/kembejeni
- / Kembeni kartushen
- / Kembeni kartushen
- / Shtrengojini manualisht tubat e lidhur
- / Kembeni unazen O



⚠️ تنبيهات الأمان

- ⚠️ يجب إرتداء قفازات الليد أثناء التركيب لتجنب حدوث أخطار الإنحشار أو الجروح
- ⚠️ يجب أن يكون تيار الماء الساخن والماء البارد متعادلين في الضغط

تعليمات التركيب

- / قبل القيام بعملية التركيب، يجب فحص المنتج للتأكد من خلوه من أية تلفيات ناتجة عن النقل بعد القيام بعملية التركيب، لن يتم الاعتراف بوجود أية تلفيات سطحية أو تلفيات ناتجة عن عملية النقل.
- / يجب تركيب وغسيل واختيار التوصيلات وخلطات المياه طبقاً للمعايير السارية.
- / يجب مراعاة القواعد الخاصة بالتركيب وأعمال السباكة وفقاً للوائح الخاصة بكل بلد.
- / 12801000: لا يمكن استخدام خلط الماء مع جهاز تسخين الماء الفوري.

المواصفات الفنية

- ضغط التشغيل: الحد الأقصى 1 ميجاباسكال
- ضغط التشغيل الموصى به: 0,5 - 0,1 ميجاباسكال
- ضغط الاختبار: 1,6 ميجاباسكال
- (1 ميجاباسكال = 10 بار = 147 PSI)
- درجة حرارة الماء الساخن: الحد الأقصى 70°C
- درجة الحرارة الموصى بها للماء الساخن: 65°C
- تعقيم حراري: الحد الأقصى 4/70°C الدقيقة
- المنتج مخصص فقط لماء الشرب!
- وصف الرمز

هام! لا تستخدم السليكون الذي يحتوي على أحماض!

أبعاد (راجع صفحة 37)

رسم للصرف (راجع صفحة 37)

التنظيف (راجع صفحة 38)

قطع الغيار (راجع صفحة 42)

- XXX = الألوان
- 000 = كروم
- Polished Chrome = 020
- Polished Bronze = 130
- Brushed Bronze = 140
- Brushed Gold-Optic = 250
- Brushed Chrome = 260
- Polished Redgold = 300
- Brushed Redgold = 310
- Polished Black Chrome = 330
- Brushed Black Chrome = 340
- Stainless Steel Optic = 800
- Brushed Nickel = 820
- Polished Nickel = 830
- Polished Brass = 930
- Brushed Brass = 950
- Polished Gold-Optic = 990

ملحقات خاصة

(غير مدرج مع المحتويات المسلمة)

محول #93395000 (G^{1/2} / G^{3/4}) (راجع صفحة 43)

التشغيل (راجع صفحة 36)

تتصح شركة هانز جروهي Hansgrohe بعدم استخدام أول نصف لتر من الماء لغرض الشرب وذلك في الصباح أو بعد توقف استخدام الماء لفترات طويلة نسبياً.

شهادة اختبار (راجع صفحة 44)

العلاج والإصلاح

السبب

العطل

الماء غير كافٍ	/ خلاط الهواء متراكم عليه الجير / الاستساخات	/ قم بتنظيف / تغيير خلط الهواء
/ الخلاط ثقيل الحركة	/ الخرطوشة تالفة، تراكم عليها الجير	/ قم بتغيير الخرطوشة
/ تساقط قطرات مياه من الخلاط	/ الخرطوشة تالفة	/ قم بتغيير الخرطوشة
/ خروج الماء من جزء التثبيت	/ خرطوم التوصيل ليست مربوطة في الجزء الرئيسي بشكل كامل	/ اربط خرطوم التوصيل بيدك
/ الحلقة الدائرية الخاصة بخرطوم التوصيل تالفة	/ الحلقة الدائرية الخاصة بخرطوم	/ قم بتغيير الحلقة الدائرية



التركيب (راجع صفحة 32)

△ BIZTONSÁGI UTASÍTÁSOK

- △ A szerelésnél a zúzódások és vágási sérülések elkerülése érdekében kesztyűt kell viselni.
- △ A hidegvíz- és a melegvíz-csatlakozások közötti nagy nyomáskülönbséget kikell egyenlíteni!

SZERELÉSI UTASÍTÁSOK

- / A szerelés előtt ellenőrizni kell, hogy a terméknek nincs-e szállítási sérülése. Beépítés után a szállítási- vagy felületi sérüléseket nem ismerik el.
- / A vezetékeket és a csaptelepet az érvényes szabványoknak megfelelően kell felszerelni, öblíteni és ellenőrizni
- / Az egyes országokban érvényes installációs irányelveket be kell tartani.
- / 12801000: A vízcsapot nem lehet átfolyós vízmelegítővel használni.

MŰSZAKI ADATOK

Üzemi nyomás:	max. 1 MPa
Ajánlott üzemi nyomás:	0,1 - 0,5 MPa
Nyomáspróba:	1,6 MPa
	(1 MPa = 10 bar = 147 PSI)
Forróvíz hőmérséklet:	max. 70°C
Forróvíz javasolt hőmérséklete:	65°C
Termikus fertőtlenítés:	max. 70°C / 4 perc

A terméket kizárólag ivóvízhez tervezték!

SZIMBÓLUMOK LEÍRÁSA



Ne használjon ecetsavtartalmú szilikon!



MÉRETET (lásd a oldalon 37)



ÁTFOLYÁSI DIAGRAMM
(lásd a oldalon 37)



TISZTÍTÁS (lásd a oldalon 38)



TARTOZÉKOK (lásd a oldalon 42)

- XXX = Szinkódolás
- 000 = Króm
- 020 = Polished Chrome
- 130 = Polished Bronze
- 140 = Brushed Bronze
- 250 = Brushed Gold-Optic
- 260 = Brushed Chrome
- 300 = Polished Redgold
- 310 = Brushed Redgold
- 330 = Polished Black Chrome
- 340 = Brushed Black Chrome

- 800 = Stainless Steel Optic
- 820 = Brushed Nickel
- 830 = Polished Nickel
- 930 = Polished Brass
- 950 = Brushed Brass
- 990 = Polished Gold-Optic

EGYÉB TARTOZÉK

(a szállítási egység nem tartalmazza)



Adapter (G $\frac{1}{2}$ / G $\frac{3}{4}$) #93395000
(lásd a oldalon 43)



HASZNÁLAT (lásd a oldalon 36)

- / A csaptelepeken átfolyt víz hőmérséklete fogyasztásra szánt víz esetében a 65°C-ot nem haladhatja meg. A csaptelep nem eredményezheti az emberi fogyasztásra (pl. ivás és főzés céljából) szánt víz minőségromlását.
- / Beüzemelés és üzemszünetek után szigorúan be kell tartani a használati útmutatóban leírtakat. Beüzemeléskor a csaptelepet át kell öblíteni, legalább 2 percig törtendő hideg- és melegvízes folyamatot javasolunk. Minimum 1 napos üzemszünet után fogyasztás előtt a csaptelepben stagnáló hideg- illetve melegvíz fogyasztása nem javasolt, a csaptelepben stagnáló vizet ki kell engedni, legalább 2 perces folyamat javasolt. A kifolytatás során nyert vizet ivóvízként, illetve ételkészítési céllal felhasználni nem szabad.
- / Tekintettel arra, hogy a forró víz fémoldó képessége a hideg vizénél nagyobb, emiatt főzés ivás céljából az OKI a hideg víz használatát javasolja.
- / A csaptelepek perlátorát javasolt havonta vízköteleníteni, illetve fertőtleníteni. A csaptelepek tisztítása, fertőtlenítése során kizárólag olyan vegyszer alkalmazható, amely megfelel a 201/2001. (X.25) Kormányrendelet, illetve a 38/2003. (VII.7) ÉSzCsM-FVM-KvVM együttes rendeletben leírtaknak.

- / A perlátor működési elvéből adódóan jelentős aeroszolt képez, így Legionella expozíció szempontjából fokozott kockázatot jelent. Ezért alkalmazása nem javasolt az egészségügyi intézmények fekvőbeteg ellátó szobáiban, illetve minden olyan helyen, ahol a hideg és/vagy használati melegvíz Legionella csíraszámja eléri a 49/2015 (XI.6.) EMMI rendelet alapján meghatározott beavatkozási szintet.



VIZSGAJEL (lásd a oldalon 44)

HIBA	OK	MEGOLDÁS
/ Kevés víz	/ A perlátor elvízkövesedett, elszennyeződött	/ A perlátort megtisztítani/kicserélni.
/ Nehezen nyitható a csap.	/ A kerámiabetét meghibásodott, elvízkövesedett.	/ A kerámiabetétet ki kell cserélni.
/ Csöpög a csap.	/ A kerámiabetét meghibásodott.	/ A kerámiabetétet ki kell cserélni.
/ Vízkilépés a rögzítőrudon	/ A csatlakozóömlők nincsenek teljesen becsavarozva az akaptestbe	/ A csatlakozóömlőket kézzel meghúzni
	/ Csatlakozóömlő tömítőgyűrűje meghibásodott	/ Tömítőgyűrű kicserélése



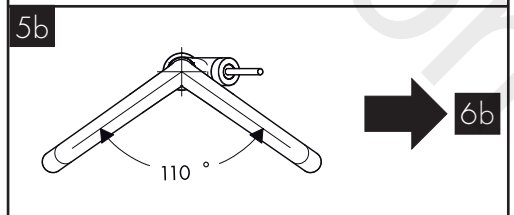
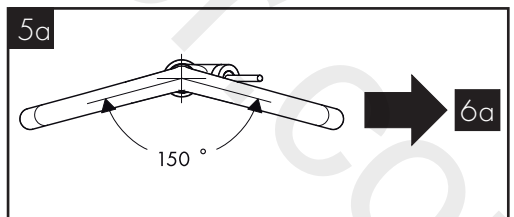
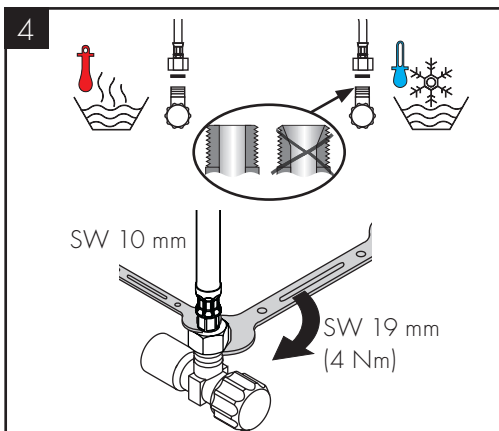
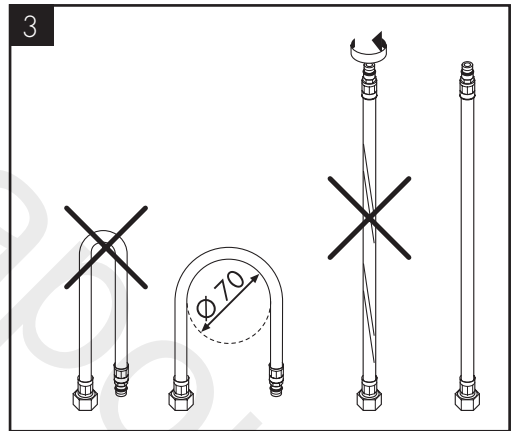
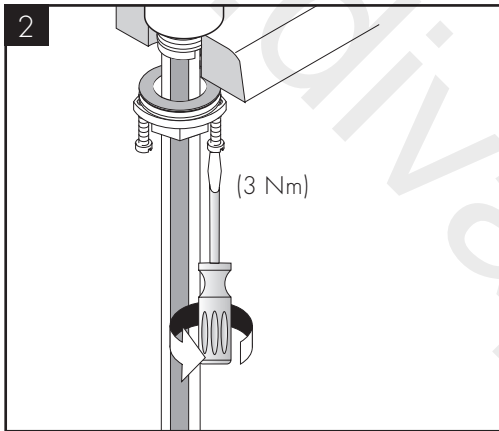
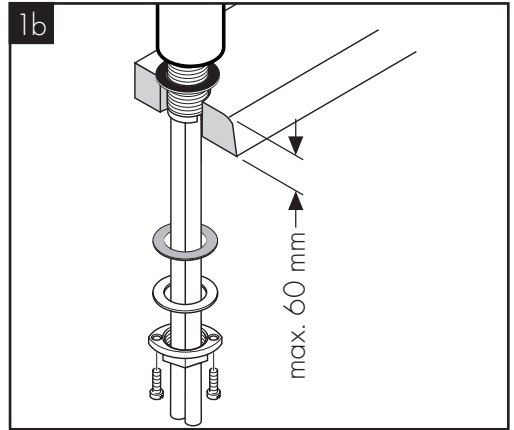
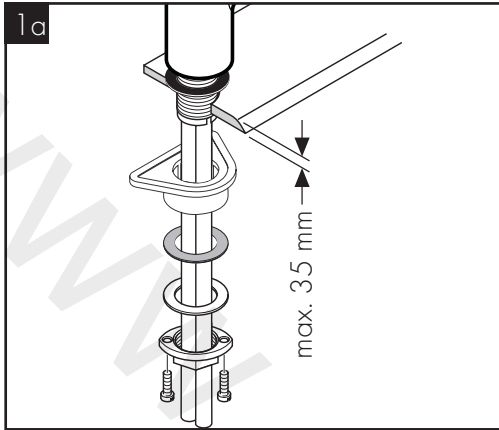



6a

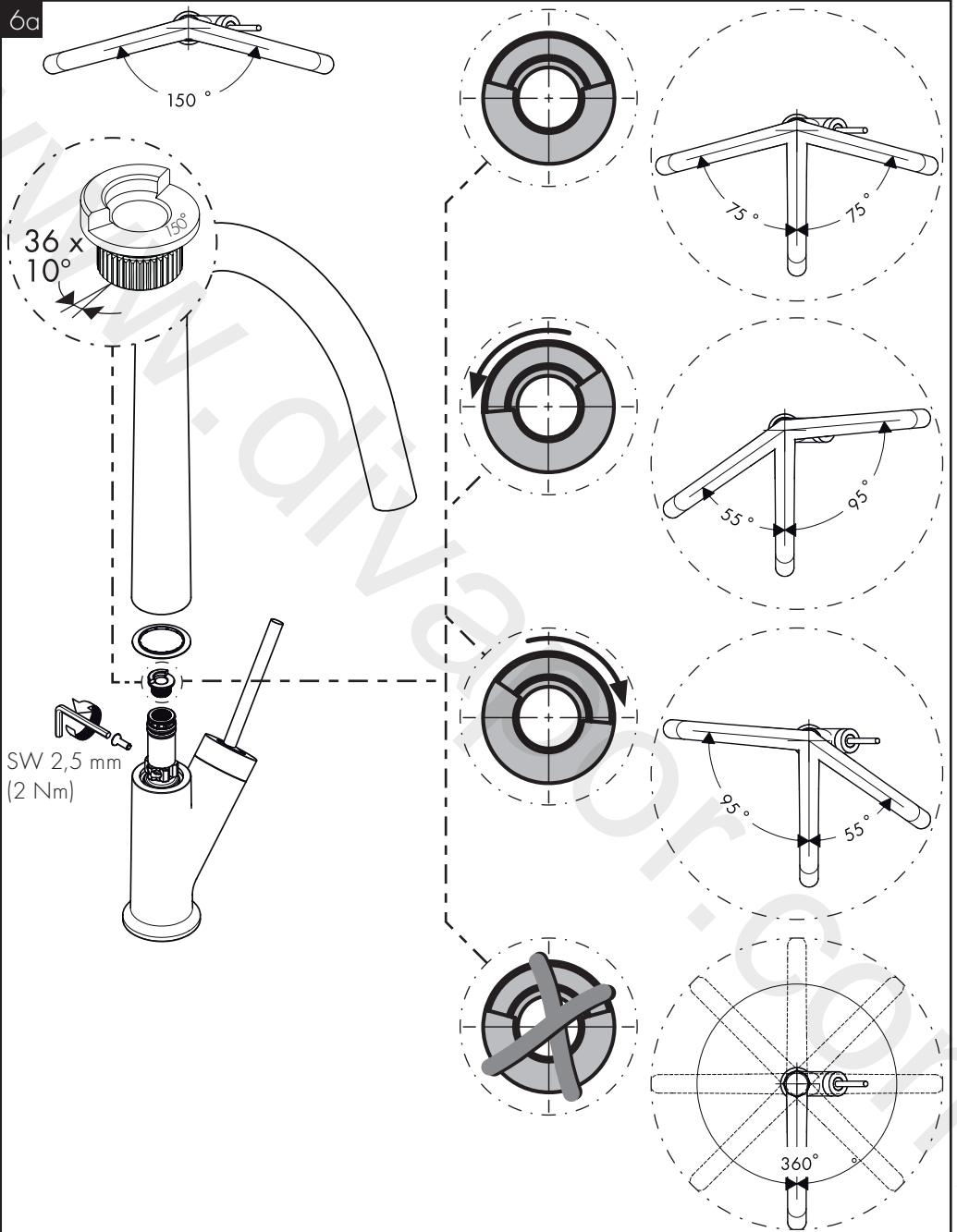



6b

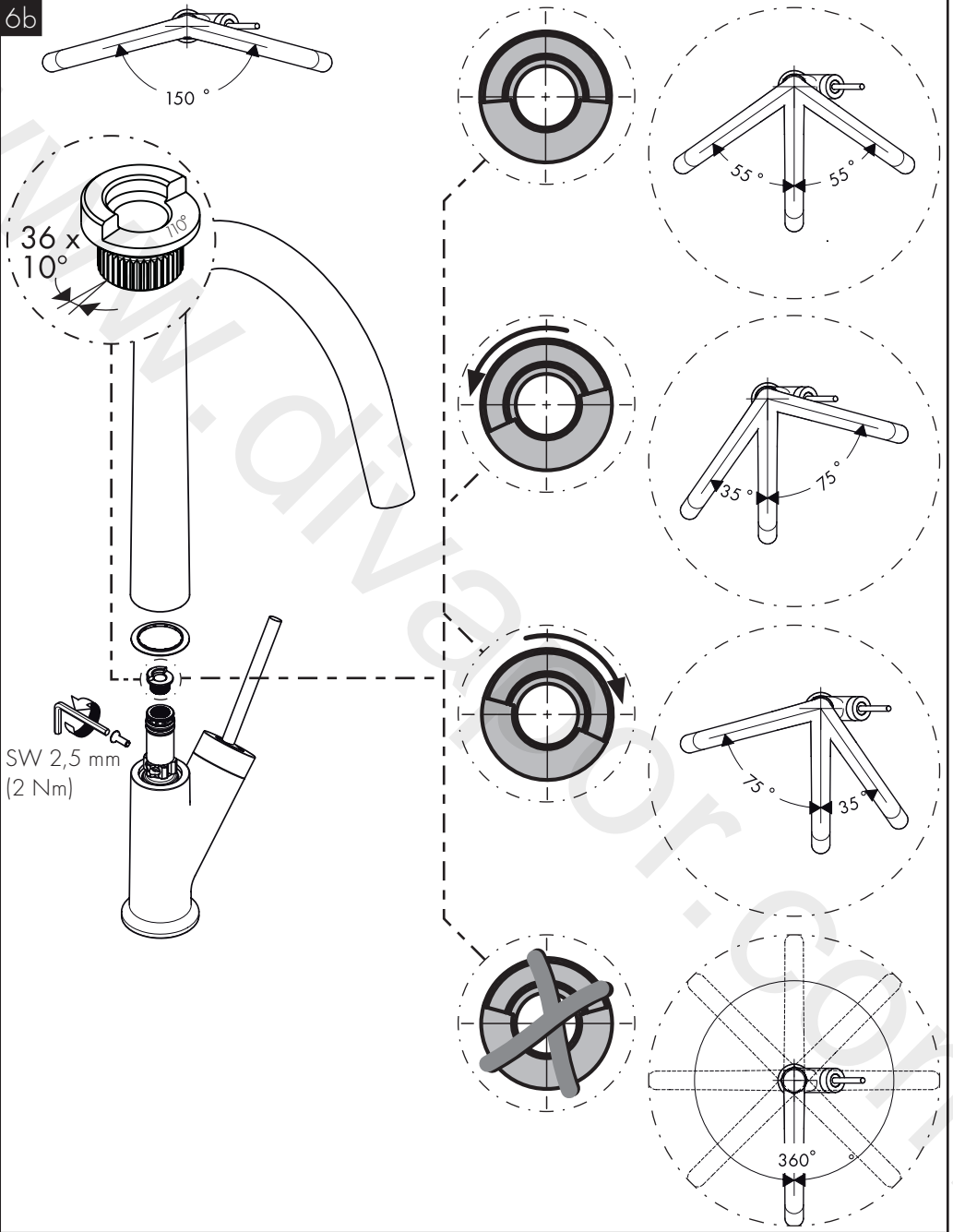

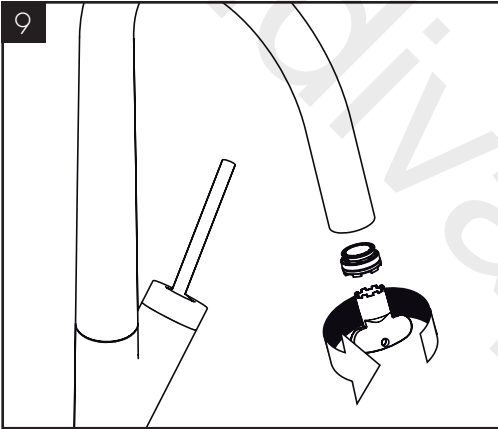
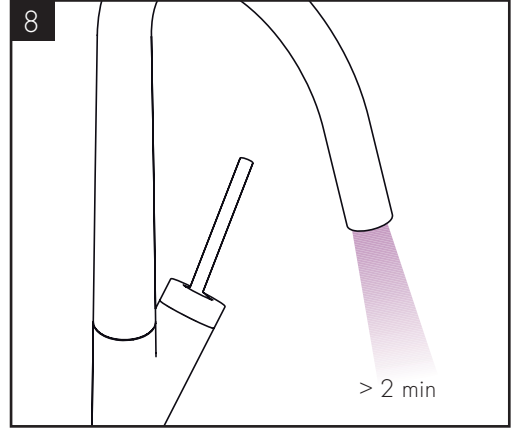
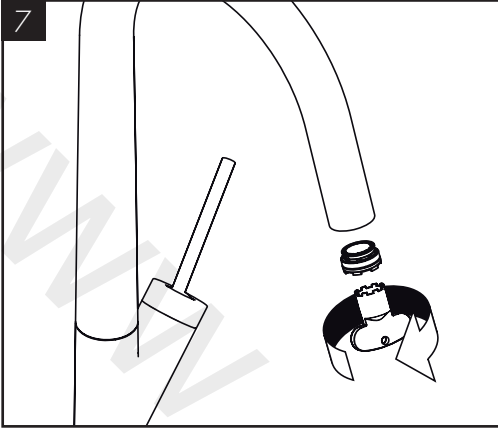

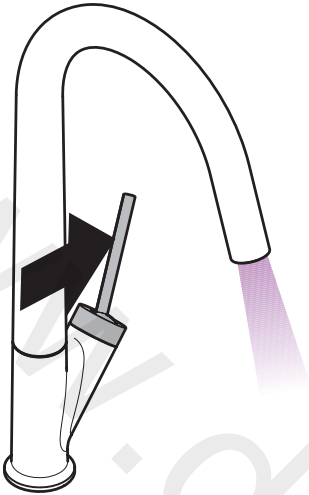

öffnen / ouvert / open / aperto / abierto / open / åbne / abrir /
otworzyć / otevřít / otvorit / 开 / открыть / nyitás /
avaaminen / öppna / atidaryti / Otvaranje / açmak /
deschide / ανοικτό / odpreti / avage / atvērt / otvoriti / åpne /
отваряне / hape / فتح

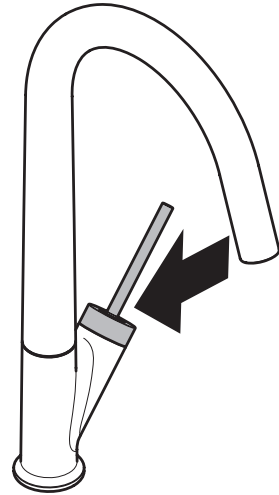

schließen / fermé / close / chiudere / cerrar / sluiten / lukke /
fechar / zamknąć / zavřít / uzavrieť / 关 / закрыть / bezárás /
sulkeminen / stänga / uždaryti / Zatvaranje / kapatmak /
ínchide / κλειστό / zapreti / sulgege / aizvērt / zatvori / lukke /
затваряне / mbylle / إغلاق

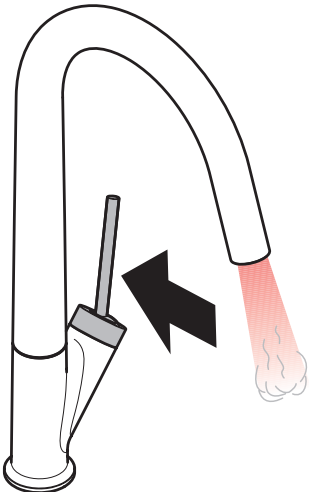

warm / chaud / hot / caldo / caliente / warm / varmt / quente /
ciepla / teplá / teplá / 热 / горячая / meleg / lämmin / varmt /
karštas / Vruća voda / sıcak / cald / ζεστό / toplo / kuum /
karsts / topla / varm / тепло / i ngrohtë / ساخن

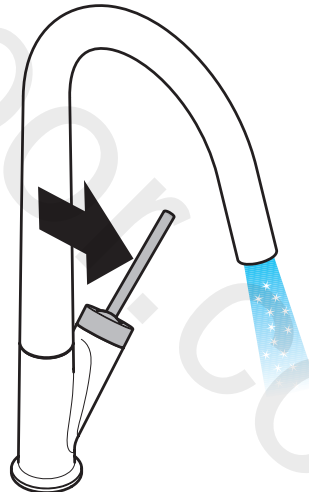

kalt / froid / cold / freddo / frío / koud / koldt / fria / zimna /
studená / studená / 冷 / холодная / hideg / kylmä / kallt /
šaltas / Hladno / soğuk / rece / κρύο / mrzlo / külm / auksts /
hladno / kaldt / студено / i ftohtë / بارد



AXOR Starck
10822XXX

AXOR Starck Eco
12801000

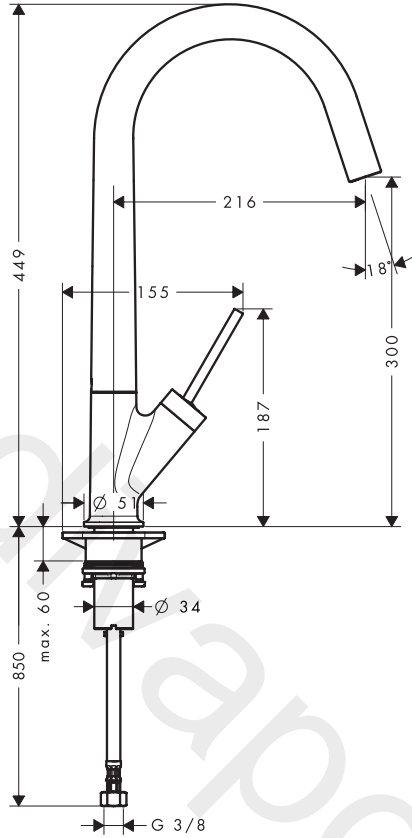

AXOR Starck
10822XXX

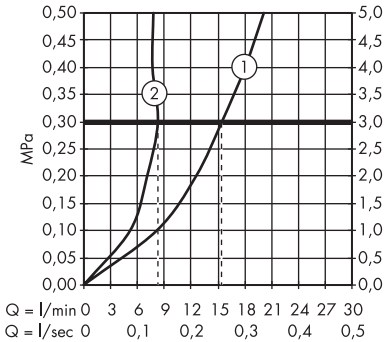

- 1 98998000 (C)
- 2 95965000 (B) (8 l/min)

AXOR Starck Eco
12801000

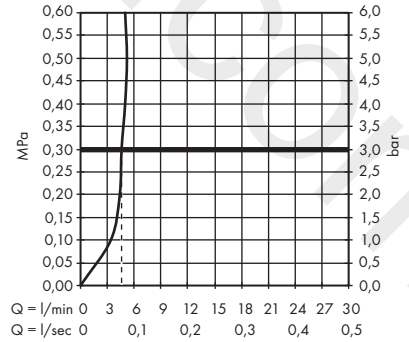



- DE / Reinigungsempfehlung / Garantie / Kontakt
 FR / Recommandation pour le nettoyage / Garanties / Contact
 EN / Cleaning recommendation / Warranty / Contact
 IT / Raccomandazione di pulizia / Garanzia / Contatto
 ES / Recomendaciones para la limpieza / Garantía / Contacto
 NL / Aanbevelingen inzake reiniging / Garantie / Contact
 DK / Rensning, anbefaling / Garanti / Kontakt
 PT / Recomendações de limpeza / Garantia / Contacto
 PL / Zalecenie dotyczące pielęgnacji / Gwarancja / Kontakt
 CS / Doporučení k čištění / Záruka / Kontakt
 SK / Odporúčania pre čistenie / Záruka / Kontakt
 ZH / 清洁指南 / 担保 / 接触
 RU / Рекомендации по очистке / Гарантия / Контакты
 HU / Tisztítási tanácsok / Garancia / érintkezés
 FI / Puhdistussuositus / Takuu / Kosketus
 SV / Rengöringsrekommendationer / Garanti / Contacto
 LT / Valymo rekomendacijos / Garantija / Kontaktai
 HR / Preporuke za čišćenje / Garancija / Kontakt
 TR / Temizleme önerisi / Garanti / Temas
 RO / Recomandări pentru curățare / Garanție / Contact
 EL / Σύσταση καθαρισμού / Εγγύηση / επαφή
 SL / Priporočilo za čiščenje / Garancija / Kontakt
 ET / Puhastussuovitused / Garantii / Kontakt
 LV / Tīrīšanas ieteikumi / Garantija / Kontakti
 SR / Preporuke za čišćenje / Garancija / Kontakt
 NO / Anbefaling for rengjøring / Garanti / Kontakt
 BG / Препоръка за почистване / Гаранция / Контакт
 SQ / Këshilla rreth pastrimit / Garancia / Kontakt
 KO / 세정시 권장사항 / 품질보증 / 접촉
 AR / توصيات التنظيف / الضمان (الولايات المتحدة الأمريكية) / اتصال



[www.axor-design.com/
cleaning-recommendation](http://www.axor-design.com/cleaning-recommendation)

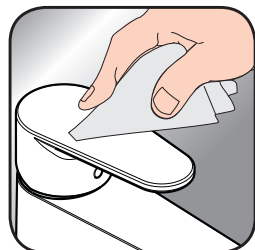

[www.axor-design.com/
cleaning-recommendation](http://www.axor-design.com/cleaning-recommendation)



[www.axor-design.com/
cleaning-recommendation](http://www.axor-design.com/cleaning-recommendation)

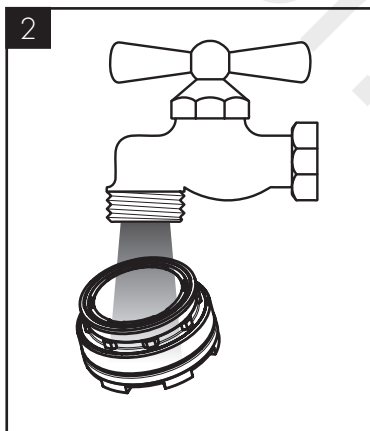
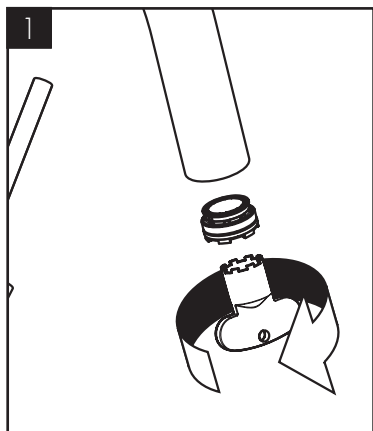

[www.axor-design.com/
cleaning-recommendation](http://www.axor-design.com/cleaning-recommendation)



EcoSmart®
93507000

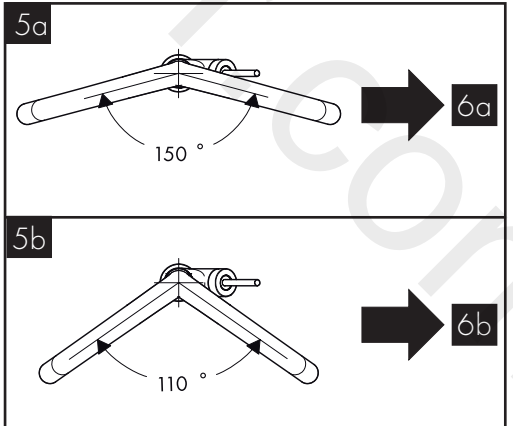
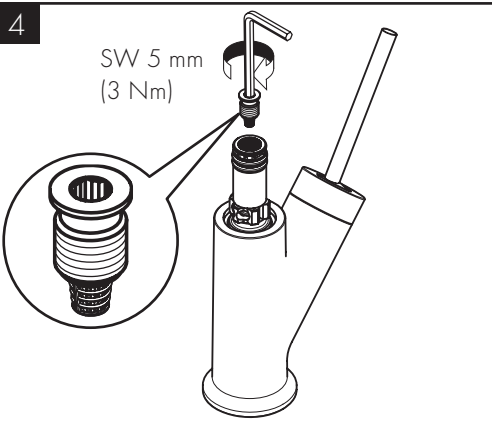
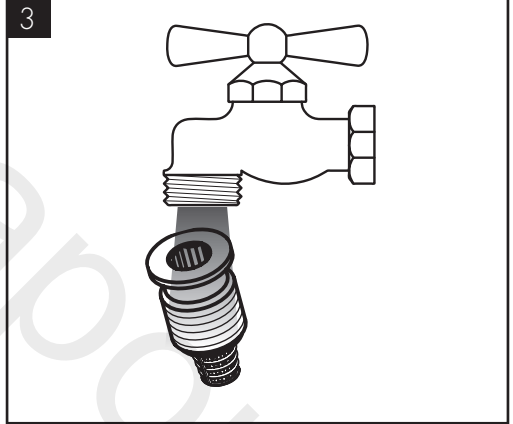
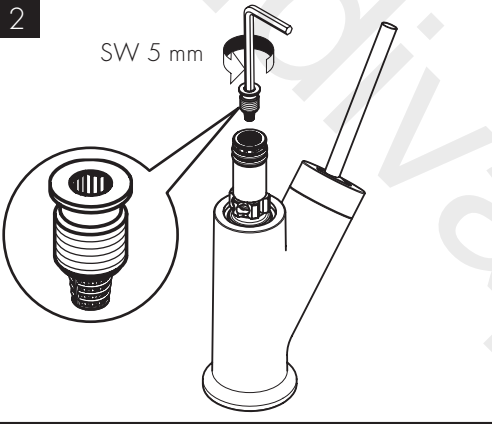
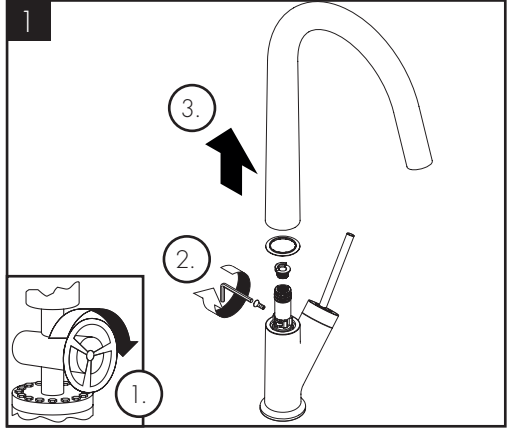



6a

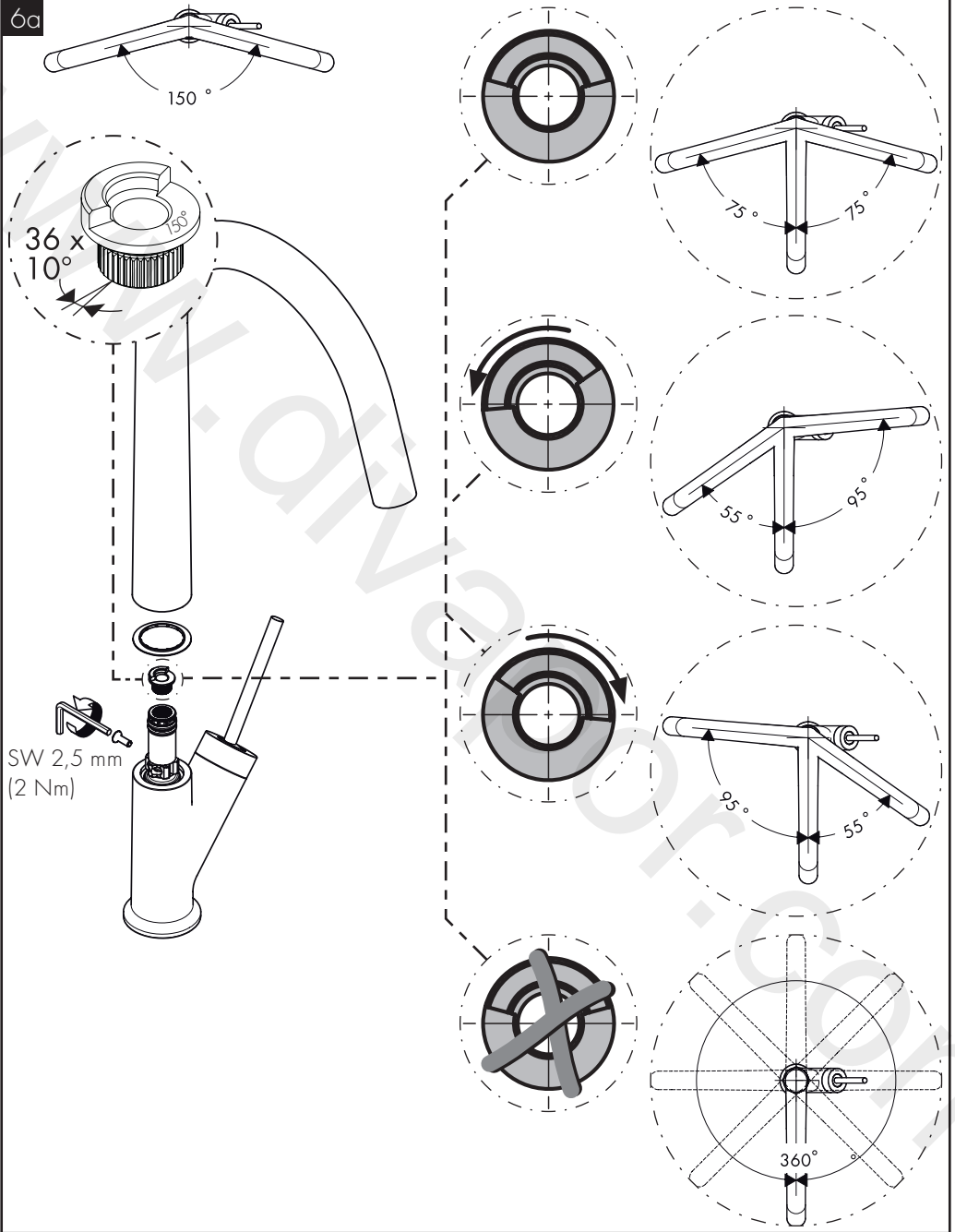



6b

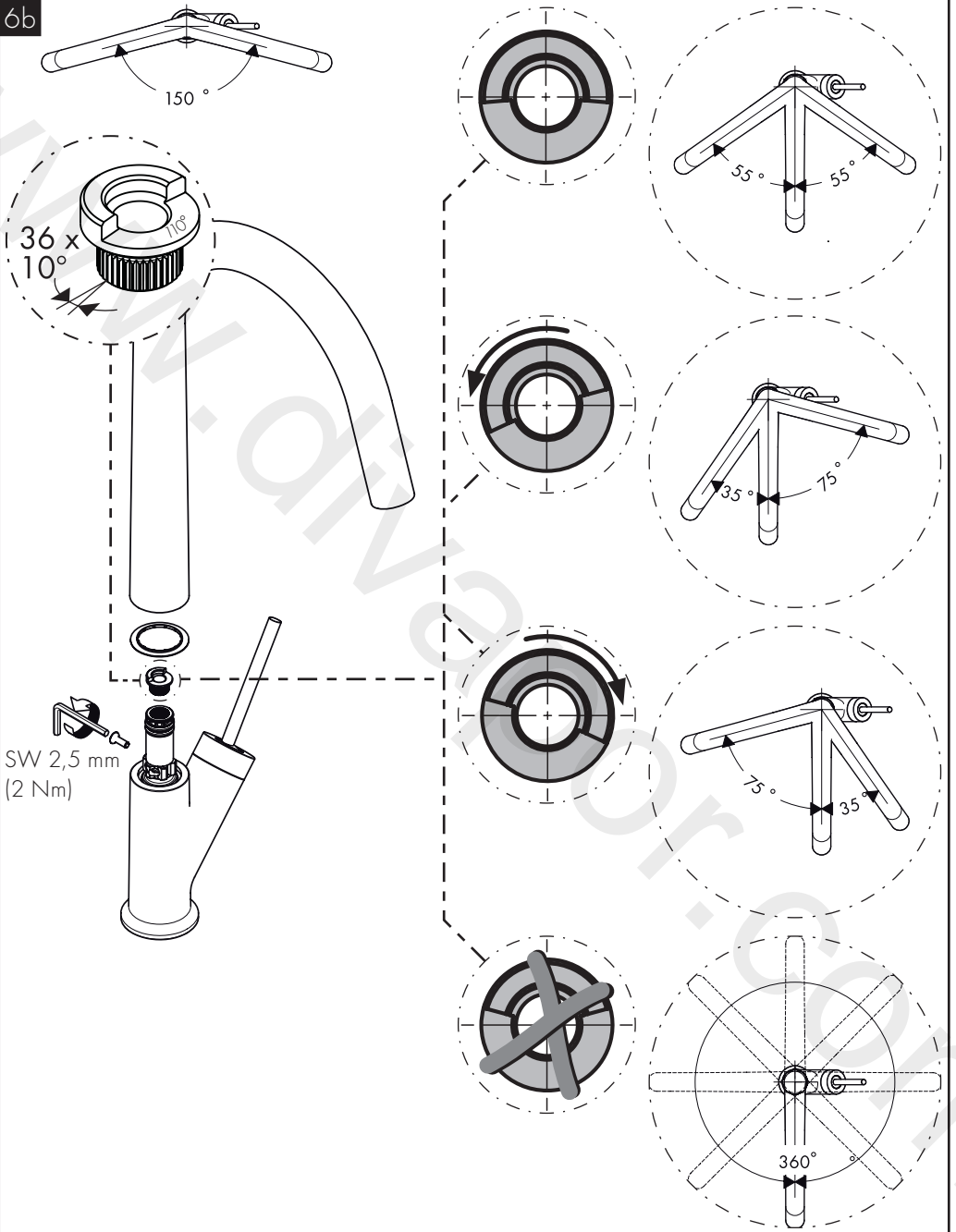



AXOR Starck
10822XXX

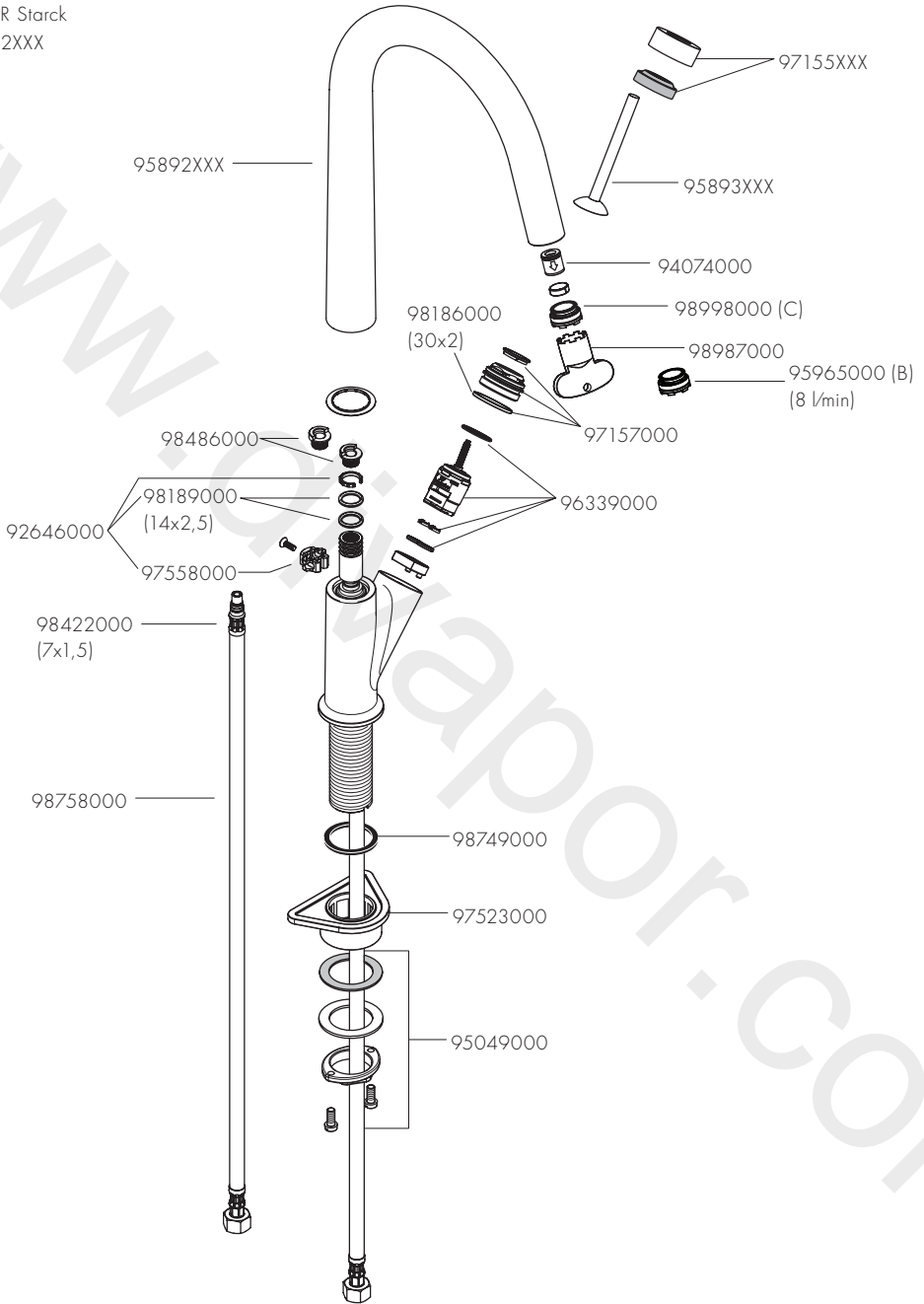



AXOR Starck Eco
12801000

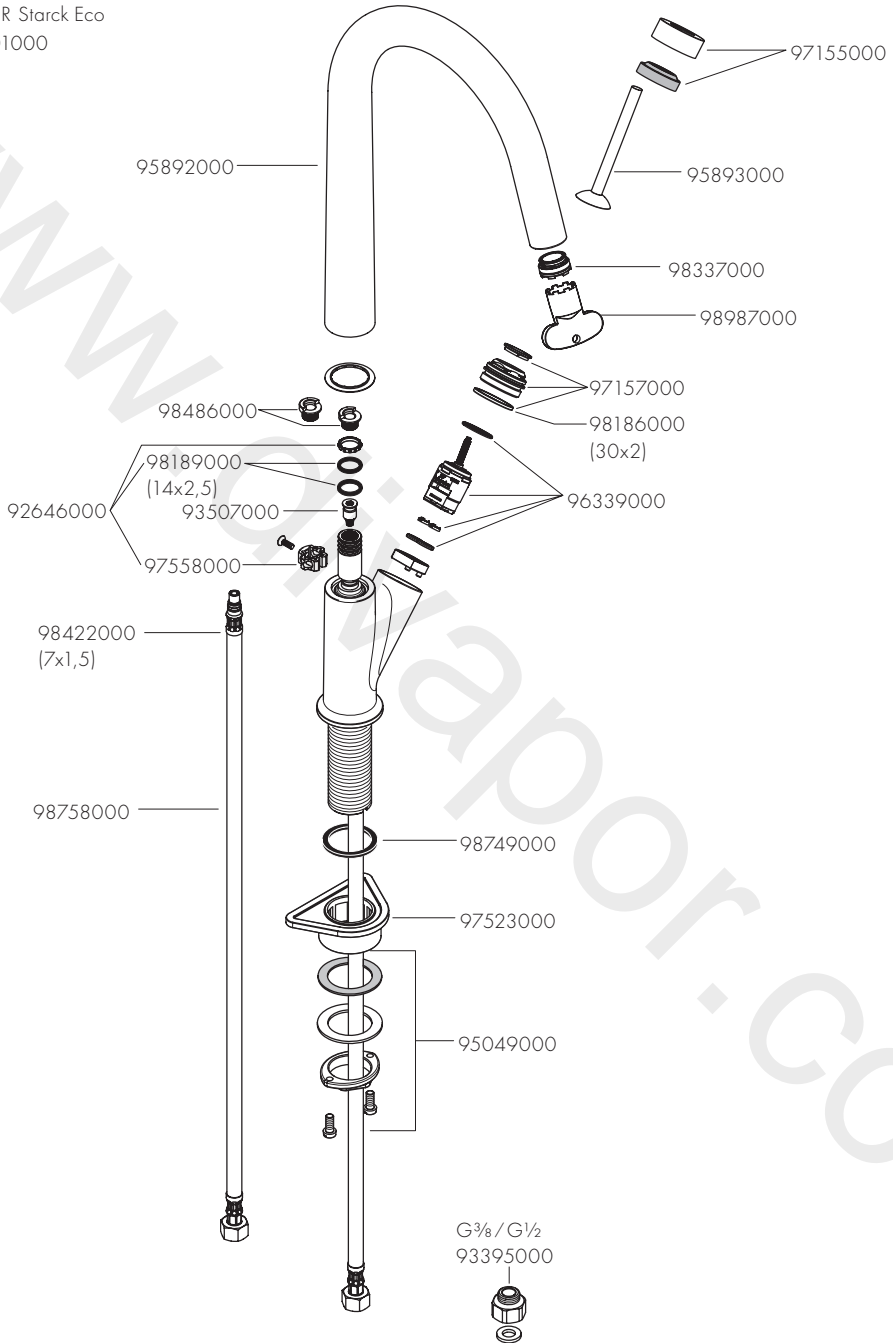

AXOR

P-IX

DVGW

SINTEF

NF



ETA



GODKENDT
TIL DRIKKEVAND

10822XXX

P-IX 19700/1C

X

X

X

12801000



AXOR / Hansgrohe SE

Austraße 5-9

77761 Schiltach

Deutschland

info@axor-design.com

axor-design.com

12/2019
9.016.82.03