

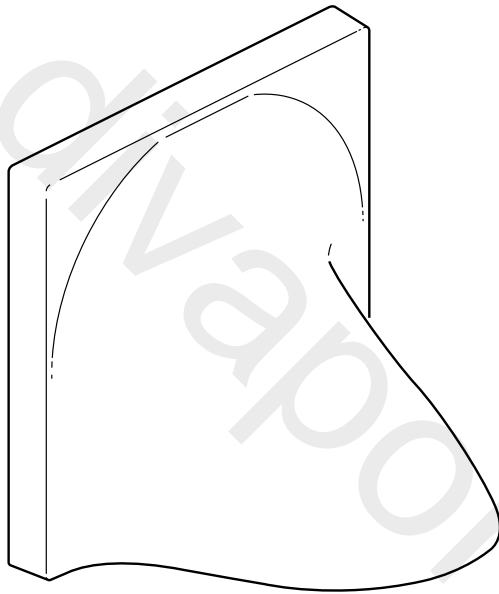

Ligature Resistant Head



PRODUCT MANUAL

IMPORTANT

INSTALLER: This product manual is the property of the customer and must be retained with the product for maintenance and operational purposes.

INTRODUCTION

The Rada Ligature Resistant Head (LR Head) is suitable for showering and handwashing use. Vandal resistant, designed to be recessed or built within the wall surface. Ideal for use in prisons and secure psychiatric facilities.

Fitted with an 8 L/Min spray cartridge providing consistent, efficient shower performance. A separate 5 L/Min flow straightener is supplied for basin use. For connection to concealed pipework using a 1/2" BSP fitting.

Design Registration

Design Registration	000709852-0001
---------------------	----------------

If you experience any difficulty with the installation or operation of your new LR Head, please read this product manual carefully before contacting Kohler Mira Ltd. Our contact details can be found on the back cover of this guide.

PACK CONTENTS

Tick the appropriate boxes to familiarise yourself with the part names and to confirm that all of the parts are included.

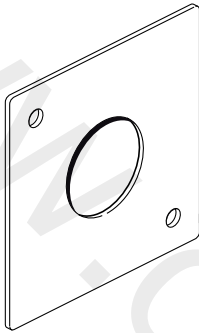

1 x LR Head Backplate

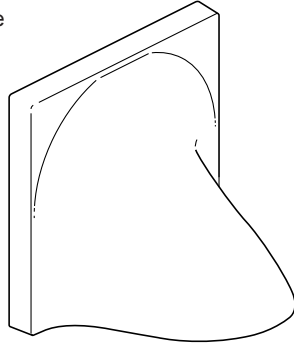

1 x LR Head
(Fitted with an 8 L/Min Spray Cartridge for Shower Applications)

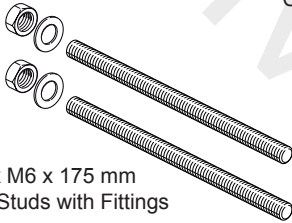

2 x M6 x 175 mm
Fixing Studs with Fittings



1 x 5 L/Min Flow Straightener
for Basin Applications

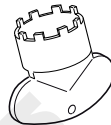

1 x Cartridge Key

SPECIFICATIONS

Temperature Range	Designed to accept water supplied between 5° C and 65° C
Pressure Range	Recommended minimum maintained pressure at the inlet of the fitting 0.5 bar. Maximum maintained pressure at the inlet of the fitting 5.0 bar (integral flow regulator fitted) Important! If the pressure at the inlet is 0.8 bar or less, it is recommended that the flow regulator is removed from the spray cartridge in order to achieve a fully formed spray pattern. Refer to section: 'Installation, Flow Regulator Removal'
Connections	1/2" BSP fitting (female thread)
Composition/Manufacture	All materials are corrosion resistant
Body	Brass, polished chrome finish
Spray Cartridge	Engineering plastic
Installation Height	Recommended Showering Installation Height is 2 metres above the floor surface

1. Installations must comply with all Local/National Water Regulations/Bye-laws (Scotland), Building and Plumbing Regulations.
2. **Warning!** Continued use of this product in conditions outside the limits listed in this section can severely affect the performance and reduce the effective service life, and can present potential risk to users.
3. **Disinfectants:** In applications where system chemical disinfection is practised, chlorine can be used (calculated chlorine concentration of 50 mg/l [ppm] maximum in water, per one hour dwell time), at service interval frequency. Such procedures must be conducted strictly in accordance with the information supplied with the disinfectant and with all relevant Guidelines/Approved Codes of Practice. If in any doubt as to the suitability of chemical solutions, refer to Kohler Mira Limited, or your Local Agent.

DIMENSIONS

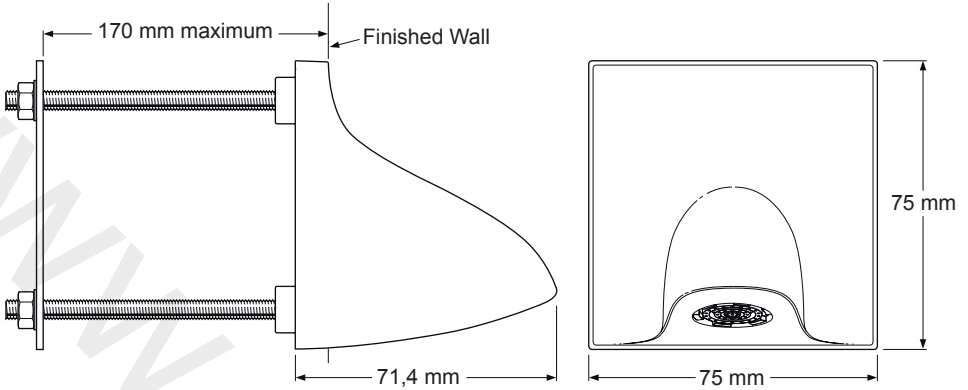

Note! The M6 fixing studs supplied allow the head to be attached through a wall to a maximum thickness of 165 mm. If longer M6 fixing studs are required, these will have to be purchased through your local supplier.

Flow Rates

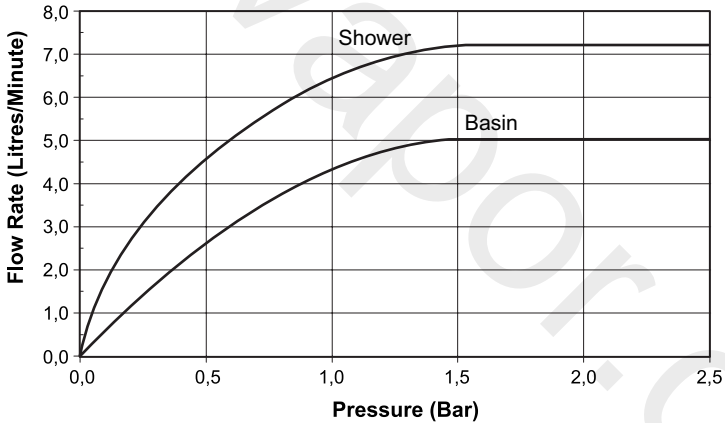

Shower and Basin Spray Projections

Shower

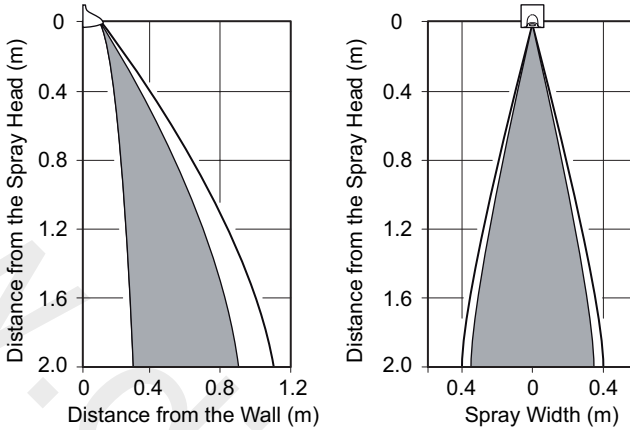

Basin Spout

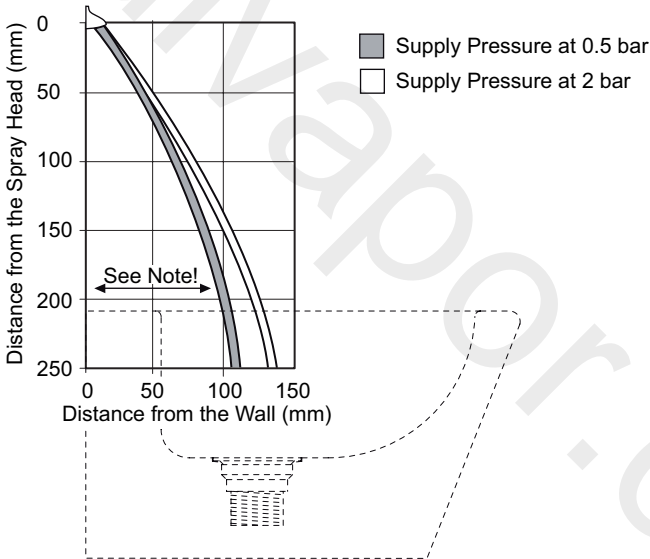

Note! The basin spout is designed for secure areas and is suitable where projection between the wall and the basin is kept to a minimum. Consideration must be given to the basin dimensions and positioning in relation to the spout spray projection, allowing for a minimum of 40 mm clearance over the rim of the basin.

INSTALLATION

General

Installation must be carried out in accordance with these instructions, and must be conducted by designated, qualified and competent personnel.

Important! The instructions contained in this product manual are for the installation of the LR Head only. If the LR Head is to be used in a controlled washroom environment, for example using a Rada Pulse System, please read both product manuals before installing your LR Head.

Flow Regulator Removal

If the supply pressure at the inlet is 0.8 bar or less it is recommended that the flow regulator is removed.

1. Use the supplied cartridge key to remove the spray cartridge from the LR Head.
2. Carefully remove the domed filter and flow regulator from the spray cartridge.
Note! Use a pair of pliers and gently squeeze the top of the filter housing in order to remove the filter and flow regulator.
3. Discard the flow regulator then refit the domed filter.
4. Refit the spray cartridge into the LR Head using the supplied cartridge key.

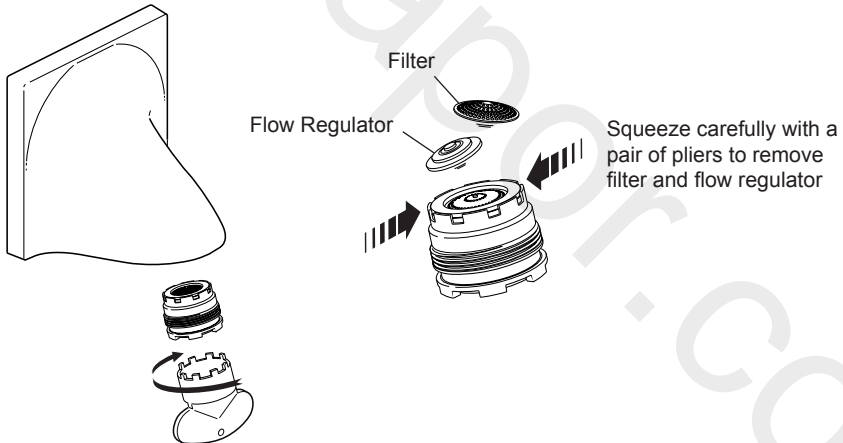

Cartridge Replacement

If the LR Head is to be used in a basin application you will need to replace the 8 L/Min spray cartridge with the 5 L/Min flow straightener.

1. Use the supplied cartridge key to remove the spray cartridge from the LR Head.
2. Install the flow straightener into the LR Head using the supplied cartridge key.

Installing the LR Head

1. Decide on a suitable location for the LR Head.
2. Position the LR Head backplate onto the level finished wall.
Note! Use a spirit level to make sure that the LR Head backplate is horizontal. Make sure the M6 fixing studs holes are in the correct position for the LR Head.
3. Mark the positions for the M6 fixing studs holes and the centre for the supply pipe.
4. Drill pilot holes for the centres of the three holes.
5. Use an electrical box sinker tool to recess the wall to a depth of 10.5 mm (± 1 mm).

Caution! The LR Head MUST be recessed or built within the wall (i.e. flush with the finished wall surface) to deliver maximum resistance to ligature and vandalism.

Note! The LR Head is the same size as a single electrical mounting box and the recommended method of recessing the LR Head is to use an Electrical Box Sinker Tool. An alternative method would be stitch drilling, then to use a club hammer and chisel.

6. To allow for the lugs on the rear of the LR Head, the fixing stud holes will require a further recess of $\text{Ø}20$ mm x 10 mm (± 1 mm).

Note! It's recommended to use a $\text{Ø}10$ mm and then a $\text{Ø}20$ mm drill bit.

7. Check that the LR Head can be installed flush with the finished wall.
8. Drill the centre hole ($\text{Ø}30$ mm) to allow for the supply pipe and fittings.

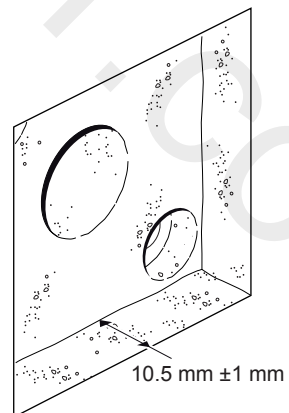
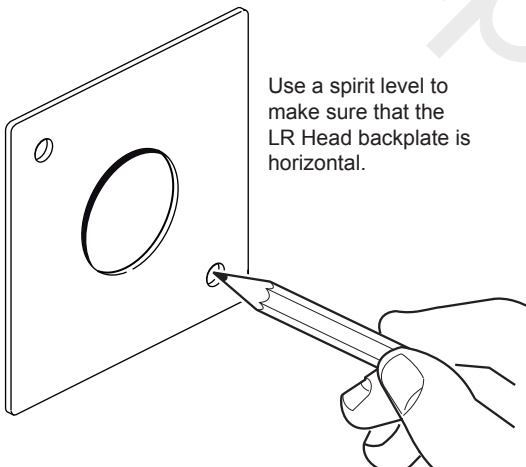

9. Attach a 1/2" BSP fitting (not supplied) to the LR Head.

Note! Inlet and outlet threaded joint connections should be made with PTFE tape or liquid sealant. Do not use oil-based, non-setting joint compounds.

Caution! Care must be taken when making this joint as leaks may not be evident as the product is installed within the wall.

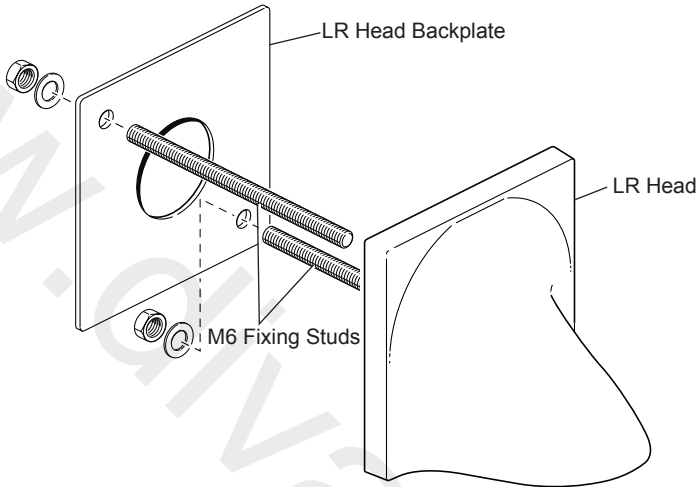

10. Fit the nut and olive onto the 15 mm copper supply pipe and attach the pipe to the 1/2" BSP fitting.

Caution! Care must be taken when making this joint as leaks may not be evident as the product is installed within the wall.

11. Attach the M6 fixing studs to the LR Head and fit into the wall.

12. Place the LR Head backplate/washers over the M6 fixing studs and secure with the nuts.

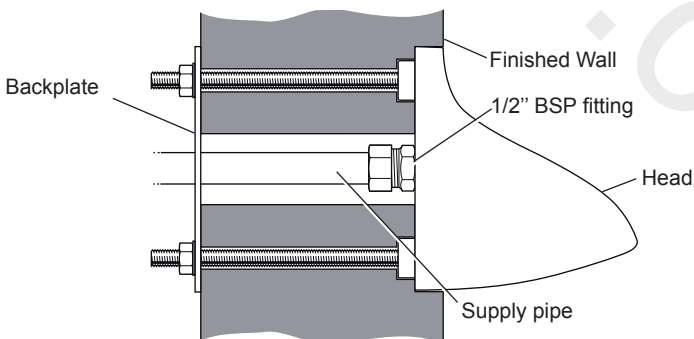

- 13.** Grout around the LR Head with a hard setting compound.
- 14.** The main supply pipe can now be attached to the LR Head supply pipe.
- 15.** To eliminate pipe debris, it is essential that the supply pipes are thoroughly flushed through before running the LR Head.
 - 15.1** Use the supplied cartridge key to remove the spray cartridge or flow straightener from the LR Head.
 - 15.2** Turn on the water supply to the LR Head and flush the pipework thoroughly.
 - 15.3** Turn off the water supply and refit the spray cartridge or flow straightener.
- 16.** This completes the installation of the LR Head.

MAINTENANCE

Cleaning

Many cleaners contain abrasive and chemical substances and should not be used for cleaning plated or plastic fittings. These finishes should be cleaned with a mild washing up detergent or soap solution and then wiped dry using a soft cloth.

FAULT DIAGNOSIS

If the LR Head is being used as part of a controlled washroom system, please refer to the fault diagnosis of the system product manual.

Note! The spray cartridges are not serviceable items, so any reduced flow or damage will require their renewal.

SPARES

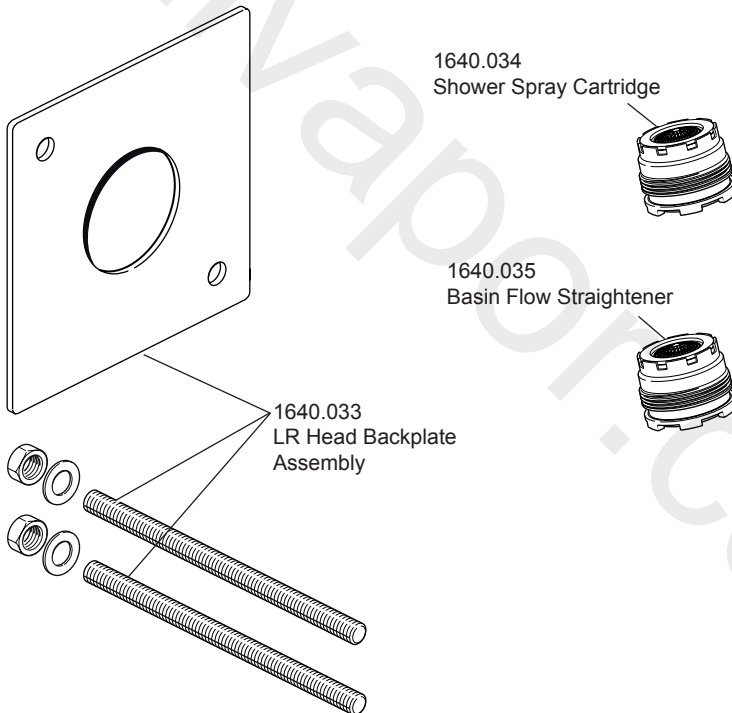

CUSTOMER CARE

Guarantee

Your product has the benefit of our manufacture's guarantee which starts from date of purchase. Within the guarantee period we will resolve defects in materials or workmanship, free of charge, by repairing or replacing parts or product as we may choose.

This guarantee is in addition to your statutory rights and is subject to the following conditions:

- The product must be installed and maintained in accordance with the instructions given in this user guide.
- Servicing must only be undertaken by us or our appointed representative. **Note!** If a service visit is required the product must be fully installed and connected to services.
- Repair under this guarantee does not extend the original expiry date. The guarantee on any replacement parts or product ends at the original expiry date.
- For shower fittings or consumable items we reserve the right to supply replacement parts only.

The guarantee does not cover:

- Call out charges for non product faults (such as damage or performance issues arising from incorrect installation, improper use, inappropriate cleaning, lack of maintenance, build up of limescale, frost damage, chemical attack, corrosion, system debris or blocked filters) or where no fault has been found with the product.
- Water or electrical supply, waste and isolation issues.
- Compensation for loss of use of the product or consequential or indirect loss of any kind.
- Damage or defects caused if the product is repaired or modified by persons not authorised by us or our appointed representative.
- Routine maintenance or replacement parts to comply with the requirements of the TMV2 or TMV3 healthcare schemes
- Accidental or wilful damage.
- Products purchased ex-showroom display.

What to do if something goes wrong

If your product does not work correctly refer to this manual for fault diagnosis and check that it is installed and commissioned in accordance with our instructions. If this does not resolve the issue, contact us for help and advice.



Technical Helpdesk Service

Contact our Customer Services Team for product advice, to purchase spare parts or accessories or to set up service visit. You can contact us via phone or e-mail - contact details below. Please provide your model name, power rating (if applicable) and date of purchase.



Rada Website (www.radacontrols.com)

From our website you can view our full product catalogue or download a brochure.



Spares and Accessories

We hold the largest stocks of genuine Rada spares and accessories.



Service/Repairs

No one knows our products better than our nationwide team of Service Technicians. We can carry out service or repair work to your product both during and after the guarantee period. You have the assurance of a fully trained Technician, genuine Rada spare parts and a 12 month guarantee on any chargeable work done.

Service Contracts

Regular servicing ensures your product continues to operate at the peak of performance. We offer annual or bi-annual servicing carried out by our fully trained technicians subject to site survey

To Contact Us - UK Customer Service & Specification Enquiries



0844 571 1777

Calls cost 7p per minute plus your phone company's access charge



Fax: 0844 472 3076



Email – Visit

rada_technical@mirashowers.com



By Post: Rada Controls, Cromwell Road, Cheltenham, Gloucestershire GL52 5EP

To Contact Us: Eire Only



01 531 9337



E-mail:

CustomerServiceEire@mirashowers.com

Rada is a registered trade mark of Kohler Mira Limited.

The company reserves the right to alter product specifications without notice.



rada