

AXOR

DE /	Gebrauchsanleitung / Montageanleitung	02
FR /	Mode d'emploi / Instructions de montage	02
EN /	Instructions for use / Assembly instructions	03
IT /	Istruzioni per l'uso / Istruzioni per Installazione	03
ES /	Modo de empleo / Instrucciones de montaje	04
NL /	Gebruiksaanwijzing / Handleiding	04
DK /	Brugsanvisning / Monteringsvejledning	05
PT /	Instruções para uso / Manual de Instalação	05
PL /	Instrukcja obsługi / Instrukcja montażu	06
CS /	Návod k použití / Montážní návod	06
SK /	Návod na použitie / Montážny návod	07
ZH /	用户手册 / 组装说明	07
RU /	Руководство пользователя / Инструкция по монтажу	08
FI /	Käyttöohje / Asennusohje	08
SV /	Brugsanvisning / Monteringsanvisning	09
LT /	Vartotojo instrukcija / Montavimo instrukcijos	09
HR /	Upute za uporabu / Uputstva za instalaciju	10
RO /	Manual de utilizare / Instrucțiuni de montare	10
EL /	Οδηγίες χρήσης / Οδηγία συναρμολόγησης	11
SL /	Navodilo za uporabo / Navodila za montažo	11
ET /	Kasutusjuhend / Paigaldusjuhend	12
LV /	Lietošanas pamācība / Montāžas instrukcija	12
SR /	Uputstvo za upotrebu / Uputstvo za montažu	13
NO /	Brugsanvisning / Montasjeveiledning	13
BG /	Инструкция за употреба / Ръководство за монтаж	14
JP /	取扱説明書 / 施工説明書	14
SQ /	Udhëzuesi i përdorimit / Udhëzime rreth montimit	15
AR /	دليل الاستخدام / تعليمات التجميع	15
TR /	Kullanım kılavuzu / Montaj kılavuzu	16
HU /	Használati útmutató / Szerelési útmutató	17
HE /	הוראות שימוש / הוראות הרכבה	17

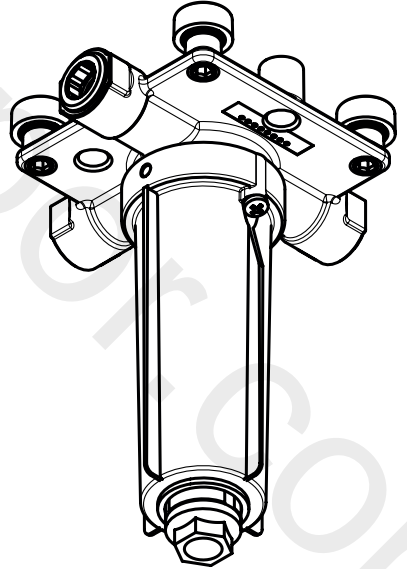

AXOR
26434180

INSTALLATION

⚠ SICHERHEITSHINWEISE

- ⚠ Bei der Montage müssen zur Vermeidung von Quetsch- und Schnittverletzungen Handschuhe getragen werden.
- ⚠ Das Produkt darf nur zu Bade-, Hygiene- und Körperreinigungszwecken eingesetzt werden.

MONTAGEHINWEISE

- / Vor der Montage muss das Produkt auf Transportschäden untersucht werden. Nach dem Einbau werden keine Transport- oder Oberflächenschäden anerkannt.
- / Die Leitungen und die Armatur müssen nach den gültigen Normen montiert, gespült und geprüft werden.
- / Die in den Ländern jeweils gültigen Installationsrichtlinien sind einzuhalten.
- / Die Decke, an die die Kopfbrause montiert werden soll, muss eine ausreichende Tragfähigkeit aufweisen.
- / Es darf nur geeignetes Befestigungsmaterial verwendet werden! Die beigelegten Schrauben und Dübel sind nur für Beton geeignet.

SYMBOLERKLÄRUNG

 Kein essigsäurehaltiges Silikon verwenden!

 INSTALLATIONSBEISPIEL
(siehe Seite 18)

 MASSE (siehe Seite 35)

 SERVICETEILE (siehe Seite 34)

SONDERZUBEHÖR
(nicht im Lieferumfang enthalten)

93941000 (siehe Seite 34)

MONTAGE 
(siehe Seite 28)

⚠ CONSIGNES DE SÉCURITÉ

- ⚠ Lors du montage, porter des gants de protection pour éviter toute blessure par écrasement ou coupure.
- ⚠ Le produit ne doit servir qu'à se laver et à assurer l'hygiène corporelle.

INSTRUCTIONS POUR LE MONTAGE

- / Avant son montage, s'assurer que le produit n'a subi aucun dommage pendant le transport. Après le montage, tout dommage de transport ou de surface ne pourra pas être reconnu.
- / Les conduites et la robinetterie doivent être montés, rincés et contrôlés selon les normes en vigueur.
- / Les directives d'installation en vigueur dans le pays concerné doivent être respectées.
- / Le plafond, sur lequel la douchette doit être montée, doit présenter une capacité de charge suffisante.
- / On ne pourra utiliser que des produits de fixation appropriés! Les vis et les chevilles livrées ne conviennent qu'au mur en béton.

DESCRIPTION DU SYMBOLE

 Ne pas utiliser de silicone contenant de l'acide acétique!

 EXEMPLE D'INSTALLATION
(voir pages 18)

 DIMENSIONS (voir pages 35)

 PIÈCES DÉTACHÉES (voir pages 34)

ACCESSOIRES EN OPTION
(ne fait pas partie de la fourniture)

93941000 (voir pages 34)

MONTAGE 
(voir pages 28)

△ SAFETY NOTES

- △ Gloves should be worn during installation to prevent crushing and cutting injuries.
- △ The product may only be used for bathing, hygienic and body cleaning purposes.

INSTALLATION INSTRUCTIONS

- / Prior to installation, inspect the product for transport damages. After it has been installed, no transport or surface damage will be honoured.
- / The pipes and the fixture must be installed, flushed and tested as per the applicable standards.
- / The plumbing codes applicable in the respective countries must be observed.
- / The ceiling to which the overhead shower is to mounted must have sufficient bearing capacity.
- / Only suitable fastening material may be used! The enclosed screws and plugs are only suitable for concrete.

SYMBOL DESCRIPTION



Do not use silicone containing acetic acid!



INSTALLATION EXAMPLE
(see page 18)



DIMENSIONS (see page 35)



SPARE PARTS (see page 34)

SPECIAL ACCESSORIES
(order as an extra)

93941000 (see page 34)

△ INDICAZIONI SULLA SICUREZZA

- △ Durante il montaggio, per evitare ferite da schiacciamento e da taglio bisogna indossare guanti protettivi.
- △ Il prodotto deve essere utilizzato esclusivamente per fare il bagno e per l'igiene del corpo.

ISTRUZIONI PER IL MONTAGGIO

- / Prima del montaggio è necessario controllare che non ci siano stati danni durante il trasporto. Una volta eseguito il montaggio, non verranno riconosciuti eventuali danni di trasporto o delle superfici.
- / Montare, lavare e controllare tubature e rubinetteria rispettando le norme correnti.
- / Vanno rispettate le direttive di installazione nazionali vigenti nel rispettivo paese.
- / Il soffitto al quale deve essere installata la doccia di testa deve presentare una capacità di portata sufficiente.
- / Usare esclusivamente del materiale di fissaggio adatto! Le viti ed i tasselli inclusi sono adatti solo per calcestruzzo.

DESCRIZIONE SIMBOLO



Non utilizzare silicone contenente acido acetico!



ESEMPIO PER L'INSTALLAZIONE
(vedi pagg. 18)



INGOMBRI (vedi pagg. 35)



PARTI DI RICAMBIO
(vedi pagg. 34)

ACCESSORI SPECIALI
(non contenuto nel volume di fornitura)

93941000 (vedi pagg. 34)

ASSEMBLY
(see page 28)



MONTAGGI
(vedi pagg. 28)



△ INDICACIONES DE SEGURIDAD

- △ Durante el montaje deben utilizarse guantes para evitar heridas por aplastamiento o corte.
- △ El producto solo debe ser utilizado para fines de baño, higiene y limpieza corporal.

INDICACIONES PARA EL MONTAJE

- / Antes del montaje se debe examinar el producto contra daños de transporte. Después de la instalación no se reconoce ningún daño de transporte o de superficie.
- / Los conductos y la grifería deben montarse, lavarse y comprobarse según las normas vigentes.
- / Es obligatorio el cumplimiento de las directrices de instalación vigentes en el país respectivo.
- / El techo en el que deba ser montada la ducha alta tiene que tener suficiente capacidad portante.
- / ¡Usar exclusivamente el material de fijación adecuado! Los tornillos y tarugos incluidos son solamente apropiados para hormigón.

DESCRIPCIÓN DE SÍMBOLOS

 No utilizar silicona que contiene ácido acético!

 EJEMPLO DE INSTALACIÓN
(ver página 18)

 DIMENSIONES (ver página 35)

 REPUESTOS (ver página 34)

OPCIONAL (no incluido en el suministro)

93941000 (ver página 34)

△ VEILIGHEIDSINSTRUCTIES

- △ Bij de montage moeten ter voorkoming van knel- en snijwonden handschoenen worden gedragen.
- △ Het product mag alleen voor het wassen, hygiënische doeleinden en voor de lichaamreiniging worden gebruikt.

MONTAGE-INSTRUCTIES

- / Vóór de montage moet het product gecontroleerd worden op transportschade. Na de inbouw wordt geen transport- of oppervlakteschade meer aanvaard.
- / De leidingen en armaturen moeten gemonteerd, gespoeld en gecontroleerd worden volgens de geldige normen.
- / De in de overeenkomstige landen geldende installatierichtlijnen moeten nageleefd worden.
- / Het plafond waaraan de hoofddouche gemonteerd moet worden, moet voldoende draagvermogen hebben.
- / Er mag alleen geschikt bevestigingsmateriaal worden gebruikt! De bijgevoegde schroeven en pluggen.

SYMBOOLBESCHRIJVING

 Gebruik geen zuurhoudende siliconen!

 INSTALLATIEVOORBEELD
(zie blz. 18)

 MATEN (zie blz. 35)

 SERVICE ONDERDELEN
(zie blz. 34)

TOEBEHOREN
(behoort niet tot het leveringspakket)

93941000 (zie blz. 34)

MONTAJE
(ver página 28)



MONTAGE
(zie blz. 28)



△ SIKKERHEDSANVISNINGER

- △ Ved monteringen skal der bruges handsker for at undgå kvæstelser og snitsår.
- △ Produktet må kun bruges til bade-, hygiejne og kropsurengøringsformål.

MONTERINGSANVISNINGER

- / Før monteringen skal produktet kontrolleres for transportskader. Efter monteringen godkendes transportskader eller skader på overfladen ikke længere.
- / Ledningerne og armaturerne skal monteres, skylles og kontrolleres iht. de gældende standarder.
- / Installationsbestemmelserne, der gælder i det enkelte land, skal overholdes.
- / Loftet, på hvilket hovedbruseren skal monteres, skal have en tilstrækkelig bæreevne.
- / Anvend kun egnet befæstigelsesmateriale. De vedlagte skruer og rawlplugs er kun egnet til beton.

SYMBOLBESKRIVELSE



Der må ikke benyttes eddikesyreholdig silikone!



INSTALLATIONSEKSEMPEL
(se s. 18)



MÅLENE (se s. 35)



RESERVEDELE (se s. 34)

SPECIALTILBEHØR (ikke med i leverings-
omfang)

93941000 (se s. 34)

△ AVISOS DE SEGURANÇA

- △ Durante a montagem devem ser utilizadas luvas de protecção, de modo a evitar ferimentos resultantes de entalamentos e de cortes.
- △ O produto só pode ser utilizado para fins de higiene pessoal.

AVISOS DE MONTAGEM

- / Antes da montagem deve-se controlar o produto relativamente a danos de transporte. Após a montagem não são aceites quaisquer danos de transporte ou de superfície.
- / As tubagens e a torneira têm que ser montadas, enxaguadas e verificadas de acordo com as normas em vigor.
- / A prescrições de instalação válidas nos respetivos países devem ser respeitadas.
- / O tecto onde pretende montar o chuveiro deve ter uma capacidade de suporte adequada.
- / Apenas deve ser utilizado material de fixação compatível. Os parafusos e buchas incluídos são apenas adequados para betão.

DESCRIÇÃO DO SÍMBOLO



Não utilizar silicone que contenha ácido acético!



EXEMPLO DE INSTALAÇÃO
(ver página 18)



MEDIDAS (ver página 35)



PEÇAS DE SUBSTITUIÇÃO
(ver página 34)

ACESSÓRIOS ESPECIAIS
(não incluído no volume de fornecimento)

93941000 (ver página 34)



Δ WSKAZÓWKI BEZPIECZEŃSTWA

- Δ Aby uniknąć zranień na skutek zgniecenia lub przecięcia, podczas montażu należy nosić rękawice ochronne.
- Δ Produkt może być używany tylko do kąpieli, higieny i czyszczenia ciała.

WSKAZÓWKI MONTAŻOWE

- / Przed montażem należy skontrolować produkt pod kątem szkód transportowych. Po montażu nie widać żadnych szkód transportowych ani szkód na powierzchni.
- / Przewody i armatura muszą być montowane, płukane i kontrolowane według obowiązujących norm.
- / Należy przestrzegać wytycznych instalacyjnych obowiązujących w danym kraju.
- / Sufit, do którego ma być zamontowany prysznic, musi posiadać wystarczającą nośność.
- / Dopuszczalne jest wykorzystanie tylko odpowiedniego materiału mocującego. Umieszczone w dostawie śruby i kołki rozporowe są przeznaczone tylko do betonu.

OPIS SYMBOLU

Nie stosować silikonów zawierających kwas octowy!



PRIKŮAD INSTALACJI
(patrz strona 18)



WYMIARY (patrz strona 35)



CZĘŚCI SERWISOWE
(patrz strona 34)

WYPOSAŻENIE SPECJALNE
(Nie jest częścią dostawy)

93941000 (patrz strona 34)

MONTÁŽ
(patrz strona 28)

**Δ BEZPEČNOSTNÍ POKYNY**

- Δ Pro zabránění řezným zraněním a pohmožděním je nutné při montáži nosit rukavice.
- Δ Produkt smí být používán pouze ke koupání a za účelem tělesné hygieny.

POKYNY K MONTÁŽI

- / Před montáží je třeba produkt zkontrolovat, zda nebyl při transportu poškozen. Po zabudování nebudou uznány žádné škody způsobené transportem nebo poškození povrchu.
- / Vedení a armatura musí být namontovány, propláchnuty a otestovány podle platných norem.
- / Je třeba dodržovat montážní pravidla platná v dané zemi.
- / Strop, ke kterému má být pevná sprcha přimontována, musí disponovat dostatečnou nosností.
- / Použit se smí jen odpovídající upevňovací materiál! Přiložené šrouby a hmoždinky jsou vhodné pouze do betonu.

POPIS SYMBOLŮ

Nepoužívat silikon s obsahem kyseliny octové!



PŘÍKLAD INSTALACE (viz strana 18)



ROZMĚRY (viz strana 35)



SERVISNÍ DÍLY (viz strana 34)

ZVLÁŠTNÍ PŘÍSLUŠENSTVÍ
(není součástí dodávky)

93941000 (viz strana 34)

MONTÁŽ
(viz strana 28)



△ BEZPEČNOSTNÉ POKYNY

- △ Pri montáži musíte nosiť rukavice, aby ste predišli pomliaždeninám a rezným poraneniam.
- △ Produkt sa smie používať len na kúpanie a telesnú hygienu.

POKYNY PRE MONTÁŽ

- / Pred montážou musíte produkt skontrolovať, či nebol počas transportu poškodený. Po zabudovaní nebudú uznané žiadne škody spôsobené transportom alebo poškodenia povrchu.
- / Potrubia a vybavenie musia byť namontované, prepláchnuté a vybavené v platnom normami.
- / Je potrebné dodržiavať smernice o inštalácii, ktoré sú práve teraz platné v krajinách.
- / Strop, na ktorý sa má namontovať stropná sprcha, musí vykazovať dostatočnú nosnosť.
- / Použit sa môže len zodpovedajúci upevňovací materiál! Priložené skrutky a hmoždinky sú vhodné iba do betónu.

POPIS SYMBOLOV

 Nepoužívať silikón s obsahom kyseliny octovej!

 PRÍKLAD INŠTALÁCIE
(viď strana 18)

 ROZMERY (viď strana 35)

 SERVISNÉ DIELY (viď strana 34)

ZVLÁŠTNE PRÍSLUŠENSTVO
(nie je súčasťou dodávky)

93941000 (viď strana 34)

△ 安全技巧

- △ 装配时为避免挤压和切割受伤, 必须戴上手套.
- △ 本产品只允许作为洗浴, 卫生和洁身之用.

安装提示

- / 安装前必须检查产品是否受到运输损害. 安装后将不认可运输损害或表面损伤.
- / 管道和阀门必须根据通用标准进行安装, 冲洗和检查.
- / 请遵守当地国家现行的安装规定.
- / 头顶花洒应当安装到天花板上, 天花板必须有足够的承重能力.
- / 仅可使用合适的紧固材料! 附带的螺丝和木钉仅适用于混凝土.

符号说明



请勿使用含有乙酸的硅胶!



安装实例 (参见第页 18)



大小 (参见第页 35)



备用零件 (参见第页 34)

选装附件 (不在供货范围内)

#93941000 (参见第页 34)

MONTÁŽ
(viď strana 28)



安装
(参见第页 28)



△ УКАЗАНИЯ ПО ТЕХНИКЕ БЕЗОПАСНОСТИ

- △ Во время монтажа следует надеть перчатки во избежание прищемления и порезов.
- △ Изделие разрешается использовать только в гигиенических целях: для принятия ванны и личной гигиены.

УКАЗАНИЯ ПО МОНТАЖУ

- / Перед монтажом следует проверить изделие на предмет повреждений при перевозке. После монтажа претензии о возмещении ущерба за повреждения при перевозке или повреждения поверхностей не принимаются.
- / Трубы и арматура должны быть установлены, промыты и проверены в соответствии с действующими нормами.
- / Необходимо соблюдать требования по монтажу, действующие в соответствующих странах.
- / Потолок, к которому будет прикручиваться верхний душ, должен иметь достаточную несущую способность.
- / Используйте только специальный крепежный материал! Приложенные винты и дюбели предназначены для работ по бетону.

ОПИСАНИЕ СИМВОЛОВ



Не применяйте силикон, содержащий уксусную кислоту.



ПРИМЕР УСТАНОВКИ
(см. стр. 18)



РАЗМЕРЫ (см. стр. 35)



КОМПЛЕКТ (см. стр. 34)

СПЕЦИАЛЬНЫЕ
ПРИНАДЛЕЖНОСТИ
(не включено в объем поставки!)

93941000 (см. стр. 34)

МОНТАЖ
(см. стр. 28)



△ TURVALLISUUSOHJEET

- △ Asennuksessa on käytettävä käsiineitä puristumien ja viiltojen aiheuttamien tapaturmien estämiseksi.
- △ Tuotetta saa käyttää ainoastaan kylpy-, hygienia- ja puhdistustarkoituksiin.

ASENNUSOHJEET

- / Ennen asennusta on tarkastettava tuotteen mahdolliset kuljetusvahingot. Asennuksen jälkeen kuljetus- ja pintavaurioita ei hyväksytä.
- / Putket ja hana on asennettava, huuhdeltava ja tarkastettava voimassa olevien standardien mukaisesti.
- / Jokaisessa maassa on noudatettava siellä päteviä asennusohjeita.
- / Katolla, johon pääsuihku asennetaan, täytyy olla riittävä kantokyky.
- / Käytä vain seinän rakenteeseen soveltuvaa kiinnitysmateriaalia! Mukana olevat ruuvit ja kiinnitystulpat soveltuvat betoniin.

MERKIN KUVAUS



Älä käytä etikkahappopitoista silikonia!



ASENNUSESIMERKKI
(katso sivu 18)



MITAT (katso sivu 35)



VARAOSAT (katso sivu 34)

ERITYISVARUSTE (ei kuulu toimitukseen)

93941000 (katso sivu 34)

ASENNUS
(katso sivu 28)



△ SÄKERHETSANVISNINGAR

- △ Handskar ska bäras under monteringsarbetet så att man kan undvika kläm- och skärskador.
- △ Produkten får bara användas till kroppshygien med bad och dusch.

MONTERINGSANVISNINGAR

- / Det måste undersökas om produkten har transportskador innan den monteras. Efter monteringen accepteras inga transport- eller ytskiktskador.
- / Ledningarna och blandaren måste monteras, spolas igenom och kontrolleras enligt de gällande normerna.
- / De installationsriktlinjer som gäller i länderna ska följas.
- / Taket där huvudduschen ska monteras måste ha tillräcklig bärfkraft.
- / Endast passande monteringsmaterial får användas! Medföljande skruvar och plugg är endast avsedda för betong.

SYMBOLFÖRKLARING



Använd inte silikon som innehåller ättiksyra!



INSTALLATIONSEXEMPEL
(se sidan 18)



MÅTTEN (se sidan 35)



RESERVDELAR (se sidan 34)

SPECIALTILLBEHÖR
(medföljer ej leveransen)

93941000 (se sidan 34)

△ SAUGUMO TECHNIKOS NURODYMAI

- △ Apsaugai nuo užspaudimo ir įsijovimo montavimo metu mūvėkite pirštines.
- △ Gaminy s turi būti naudojamas tik maudymuisi, kūno higienai ir švarai palaikyti.

MONTAVIMO INSTRUKCIJA

- / Prieš montuojant būtina patikrinti, ar gaminy nebuvo pažeistas transportavimo metu. Sumontavus pretenzijos dėl transportavimo ir paviršiaus pažeidimų nepriimamos.
- / Vamzdžiai ir sujungimai turi būti montuojami, plaunami ir tikrinami pagal galiojančias normas.
- / Laikykitės atitinkamoje šalyje galiojančių direktyvų dėl įrengimo.
- / Lubos, prie kurių montuojama dušo galva, turi būti pakankamai tvirtos.
- / Gali būti naudojamos tik tam tinkamos tvirtinimo medžiagos! Komplektuojami varžtai ir kaištukai pritaikyti tik betonui.

SIMBOLIO APRĄŠYMAS



Nenaudokite silikono, kurio sudėtyje yra acto rūgšties!



ĮRENGIMO PAVYZDŽIAI
(žr. psl. 18)



IŠMATAVIMAI (žr. psl. 35)



ATSARGINĖS DALYS (žr. psl. 34)

SPECIALŪS PRIEDAI (nėra pridedama)

93941000 (žr. psl. 34)



△ SIGURNOSNE UPUTE

- △ Prilikom montaže se radi sprječavanja prignječenja i posjekotina moraju nositi rukavice.
- △ Proizvod se smije primjenjivati samo za kupanje, tuširanje i osobnu higijenu.

UPUTE ZA MONTAŽU

- / Prije montaže mora se provjeriti je li proizvod oštećen prilikom transporta. Nakon ugradnje se ne priznaju nikakve reklamacije koje se odnose na površinska i transportna oštećenja.
- / Cijevi i armatura moraju biti postavljeni, isprani i testirani prema važećim normama.
- / Obvezno se moraju uvažiti propisi o instalacijama koji vrijede u dotičnoj zemlji.
- / Strop na koji treba postaviti tuš iznad glave mora biti dostatne nosivosti.
- / Smije se koristiti samo prikladni pričvrсни materijal! Priloženi vijci i moždanici prikladni su samo za beton.

OPIS SIMBOLA



Nemojte koristiti silikon koji sadrži octenu kiselinu!



PRIMJER INSTALACIJE
(pogledaj stranicu 18)



MJERE (pogledaj stranicu 35)



REZERVNI DJELOVI
(pogledaj stranicu 34)

POSEBNI PRIBOR
(Nije sadržano u isporucil)

93941000 (pogledaj stranicu 34)

△ INSTRUCȚIUNI DE SIGURANȚĂ

- △ La montare utilizați mănuși pentru evitarea contuziunilor și tăierii mâinilor.
- △ Produsul poate fi utilizat doar pentru spălarea, menținerea igienei și curățarea corpului.

INSTRUCȚIUNI DE MONTARE

- / Înainte de instalare verificați, dacă produsul prezintă deteriorări de transport. După instalare garanția nu acoperă deteriorările de transport și cele de suprafață.
- / Conductele și bateriile trebuie montate, spălate și verificate conform normelor în vigoare.
- / Respectați reglementările referitoare la instalare valabile în țara respectivă.
- / Tavanul pe care urmează să montați dușul de tavan, trebuie să aibă o capacitate portantă corespunzătoare.
- / Utilizați numai materiale de montare corespunzătoare! Șuruburile și diblurile livrate sunt potrivite pentru ziduri de beton.

DESCRIEREA SIMBOLURILOR



Nu utilizați silicon cu conținut de acid acetic!



EXEMPLU DE INSTALARE
(vezi pag. 18)



DIMENSIUNI (vezi pag. 35)



PIESE DE SCHIMB (vezi pag. 34)

ACCESORII OPȚIONALE
(nu este inclus în setul livrat)

93941000 (vezi pag. 34)

SASTAVLJANJE
(pogledaj stranicu 28)



MONTARE
(vezi pag. 28)



⚠ ΥΠΟΔΕΙΞΕΙΣ ΑΣΦΑΛΕΙΑΣ

- ⚠ Για να αποφύγετε τραυματισμούς κατά τη συναρμολόγηση πρέπει να φοράτε γάντια.
- ⚠ Το προϊόν επιτρέπεται να χρησιμοποιείται μόνο σαν μέσο λουτρού, υγιεινής και καθαρισμού του σώματος.

ΟΔΗΓΙΕΣ ΣΥΝΑΡΜΟΛΟΓΗΣΗΣ

- / Πριν τη συναρμολόγηση πρέπει να εξεταστεί το προϊόν για ζημιές μεταφοράς. Μετά την εγκατάσταση δεν αναγνωρίζονται ζημιές από τη μεταφορά ή επιφανειακές ζημιές.
- / Οι σωλήνες και η μπαταρία πρέπει να τοποθετηθούν σύμφωνα με τα ισχύοντα πρότυπα, να τεθούν υπό πίεση και να δοκιμαστούν.
- / Θα πρέπει να τηρούνται οι οδηγίες εγκατάστασης που ισχύουν σε κάθε κράτος.
- / Η οροφή στην οποία πρόκειται να στερεωθεί το ντους κεφαλιού πρέπει να έχει επαρκή φέρουσα ικανότητα.
- / Επιτρέπεται η χρήση μόνο κατάλληλων υλικών σταθεροποίησης! Οι συνημμένες βίδες και στυλίσκοι είναι κατάλληλοι μόνο για ακυροκόνιαμα (μπετόν).

ΠΕΡΙΓΡΑΦΗ ΣΥΜΒΟΛΩΝ



Μην χρησιμοποιείτε σιλικόνη που περιέχει οξικό οξύ!



ΠΑΡΑΔΕΙΓΜΑ ΕΓΚΑΤΑΣΤΑΣΗΣ
(βλ. Σελίδα 18)



ΔΙΑΣΤΑΣΕΙΣ (βλ. Σελίδα 35)



ΑΝΤΑΛΛΑΚΤΙΚΑ (βλ. Σελίδα 34)

ΕΙΔΙΚΑ ΑΞΕΣΟΥΑΡ (δεν περιλαμβάνεται στον παραδοτέο εξοπλισμό)

93941000 (βλ. Σελίδα 34)

⚠ VARNOSTNA OPOZORILA

- ⚠ Pri montaži je treba nositi rokavice, da se preprečijo poškodbe zaradi zmečkanja ali urezov.
- ⚠ Ta izdelek se sme uporabljati le z namenom umivanja, vzdrževanja higiene in telesne nege.

NAVODILA ZA MONTAŽO

- / Pred montažo je treba izdelek preveriti glede morebitnih transportnih poškodb. Po vgradnji transportne ali površinske poškodbe ne bodo več priznane.
- / Cevi in armaturo je treba montirati, izprati in preveriti po veljavnih standardih.
- / Upoštevati je treba pravilnike o inštalacijah, ki veljajo v posamezni državi.
- / Strop, na katerega se montira stropna prha, mora zagotavljati zadostno nosilnost.
- / Uporabi se lahko le primeren pritrditveni material! Priloženi vijaki in mozniki so primerni le za beton.

OPIS SIMBOLA



Ne smete uporabiti silikona, ki vsebuje očetno kislino!



PRIMER INŠTALACIJE
(glejte stran 18)



MERE (glejte stran 35)



REZERVNI DELI (glejte stran 34)

POSEBEN PRIBOR (Ni vključeno)

93941000 (glejte stran 34)







△ OHUTUSJUHISED

- △ Kandke paigaldamisel muljumis- ja löikevigastuste vältimiseks kindaid.
- △ Toodet tohib kasutada ainult pesemis-, hügieeni- ja kehahügieenimärkidel.

PAIGALDAMISJUHISED

- / Enne paigaldamist tuleb toodet kontrollida transpordikahjustuste osas. Pärast paigaldamist ei tunnustata enam transpordi- või pinnakahjustuste kaebuseid.
- / Voolikute ja segisti paigaldamisel, loputamisel ja kontrollimisel tuleb lähtuda kehtivatest normatiividest.
- / Vastavas riigis kehtivaid paigalduseeskirju tuleb järgida.
- / Lael, kuhu dušš paigaldatakse, peab olema piisav kande võime.
- / Kasutage ainult sobivat kinnitusmaterjali! Kaasas olevad kruvid ja kinnitid sobivad vaid betoonile.

SÜMBOLITE KIRJELDUS

-  Ärge kasutage äädikhapet sisaldavat silikooni!
-  PAIGALDUSNÄIDE (vt lk 18)
-  MÕÖTUDE (vt lk 35)
-  VARUOSAD (vt lk 34)
-  SPETSIAALNE LISAVARUSTUS (ei sisaldu komplektis)
- # 93941000 (vt lk 34)





△ DROŠĪBAS NORĀDES

- △ Montāžas laikā, lai izvairītos no saspiedumiem un iegriezumiem, nepieciešams nēsāt cimdus.
- △ Šo produktu drīkst izmantot tikai, lai mazgātos, higiēnai un ķermeņa tīrīšanai.

NORĀDĪJUMI MONTĀŽAI

- / Pirms montāžas nepieciešams pārbaudīt, vai produktam transportēšanas laikā nav radušies bojājumi. Pēc iebūvēšanas bojājumi, kas radušies transportēšanas laikā, vai virsmas bojājumi netiek atzīti.
- / Cauruļvadi ar armatūra ir jāuzstāda, jāizskalo un jāpārbauda saskaņā ar spēkā esošajiem standartiem.
- / Jāievēro attiecīgās valstīs spēkā esošās montāžas prasības.
- / Griestiem, pie kādiem pieskrūvējama augšējā duša, jābūt ar pietiekošu nesējspēku.
- / Drīkst izmantot tikai piemērotus stiprinājuma materiālus! Komplektā esošās skrūves un dībeļi ir piemēroti tikai betonam.

SIMBOLU NOZĪME

-  Neizmantot silikonu, kas satur etiķskābi!
-  UZSTĀDĪŠANAS PIEMĒRS (skat. lpp. 18)
-  IZMĒRUS (skat. lpp. 35)
-  REZERVES DAĻAS (skat. lpp. 34)
-  SPECIĀLI AKSESUĀRI (komplektā netiek piegādāts)
- # 93941000 (skat. lpp. 34)

△ SIGURNOSNE NAPOMENE

- △ Prilikom montaže se radi sprečavanja prignječenja i posekotina moraju nositi rukavice.
- △ Proizvod sme da se koristi samo za kupanje, tuširanje i ličnu higijenu.

INSTRUKCIJE ZA MONTAŽU

- / Pre montaže se mora proveriti da li je proizvod oštećen pri transportu. Nakon ugradnje se ne priznaju nikakve reklamacije koje se odnose na površinska i transportna oštećenja.
- / Vodovi i armatura moraju biti postavljeni, isprani i testirani prema važećim normama.
- / Treba se pridržavati propisa koji u određenim zemljama važe za instalacije.
- / Tavanica na koju treba da se montira tuš iznad glave mora imati dovoljnu nosivost.
- / Sme se koristiti samo prikladni pričvršni materijal! Priloženi vijci i tiplovi prikladni su samo za beton.

OPIS SIMBOLA



Nemojte koristiti silikon koji sadrži sircetnu kiselinu!



PRIMER INSTALACIJE
(vidi stranu 18)



MERE (vidi stranu 35)



REZERVNI DELOVI (vidi stranu 34)

POSEBAN PRIBOR (Nije sadržano u isporuci)

93941000 (vidi stranu 34)

△ SIKKERHETSHENVISNINGER

- △ Bruk hansker under montasjen for å unngå klem- og kuttskader.
- △ Produktet skal kun brukes for bade-, hygiene- og kroppshygiene.

MONTAGEHENVISNINGER

- / Før montasjen skal produktet sjekkes for transportskader. Etter monteringen aksepteres ikke noen transport- eller overflateskader.
- / Ledningene og armaturen skal monteres, spyles og sjekkes iht. de gyldige normer.
- / Gjeldende retningslinjer for rørleggerarbeid i de enkelte land skal følges.
- / Taket, der hodedusjen skal monteres, må ha en tilstrekkelig bæreevne.
- / Det skal kun brukes egnet festematerial. Medleverte skruer og pluggen egner seg kun for betong.

SYMBOLBESKRIVELSE



Ikke bruk silikon som inneholder eddiksyre!



INSTALLASJONSEKSEMPEL
(se side 18)



MÅL (se side 35)



SERVICEDELER (se side 34)

EKSTRATILBEHØR
(ikke med i leveransen)

93941000 (se side 34)

MONTAŽA 
(vidi stranu 28)

MONTASJ 
(se side 28)

△ УКАЗАНИЯ ЗА БЕЗОПАСНОСТ

- △ При монтажа трябва да се носят ръкавици, за да се избегнат наранявания поради притискане или порязване.
- △ Позволено е използването на продукта само за къпане, хигиена и цели на почистване на тялото.

УКАЗАНИЯ ЗА МОНТАЖ

- / Преди монтажа продуктът трябва да се провери за транспортни щети. След монтажа не се признават транспортни или повърхностни щети.
- / Тръбопроводите и арматурата трябва да се монтира, промият и проверят в съответствие с валидните норми.
- / Трябва да бъдат спазвани валидните в съответните страни предписания за инсталиране.
- / Таванът, на който трябва да се монтира разпръсква-телят за главата, трябва да има достатъчна товаро-носимост.
- / Позволено е единствено използване на подходящи материали за закрепване! Приложените винтове и дюбели са подходящи само за бетон.

ОПИСАНИЕ НА СИМВОЛИТЕ



Не използвайте силикон, съдържащ оцетна киселина!



ПРИМЕР ЗА ИНСТАЛАЦИЯ
(вижте стр. 18)



РАЗМЕРИ (вижте стр. 35)



СЕРВИЗНИ ЧАСТИ (вижте стр. 34)

СПЕЦИАЛНИ ПРИНАДЛЕЖНОС-ТИ
(не се съдържа в обема на доставка)

93941000 (вижте стр. 34)

МОНТАЖ
(вижте стр. 28)



△ 安全上の注意

- △ 施工の際は手を挟んだり怪我をしないように、手袋をはめてください。
- △ この製品は、体や手を洗う等の製品本来の目的以外には使用しないでください。

施工上の注意

- / 製品の施工前に輸送でのダメージがないか確認してください。施工後のキズ等のお申し出はお断りさせていただきます。
- / 配管と水栓は、関連法規に従って施工、洗浄、および試験を行ってください。
- / 施工行う地域に適用される関連法規をお守りください。
- / オーバーヘッドシャワーを取り付ける天井には、十分な強度・耐荷重が必要です。
- / 施工に適した取付金具を使用してください。同梱のネジとプラグ (アンカー) は、コンクリート用です。

アイコンの説明



酢酸系シリコンをご使用にならないでください!



施工例 (次のページを参照 18)



寸法 (次のページを参照 35)



スペアパーツ (次のページを参照 34)

スペシャルパーツ (別手配部品)

#93941000 (次のページを参照 34)

施工方法
(次のページを参照 28)



△ UDHËZIME SIGURIE

- △ Për të evituar lëndimet e pickimeve ose të prerjeve gjatë procesit të montimit duhet që të vishni doreza.
- △ Produkti duhet të përdoret vetëm qëllimet e banjave, të higjienës dhe të larjes së trupit.

UDHËZIME PËR MONTIMIN

- / Përpara montimit duhet që produkti të kontrollohet për dëmtime nga transporti. Pas instalimit nuk do të njihet asnjë dëmtim nga transporti ose dëmtim i sipërfaqes.
- / Tubacionet dhe rubinetet duhet që të montohen, të shpëlahen dhe të kontrollohen sipas standardeve në fuqi
- / Duhet të respektohen linjat udhëzuese të instalimit, të vlefshme për vendet respektive.
- / Tavani, mbi të cilin do të montoni pllakën e dushit, duhet të ketë aftësi mbajtëse të mjaftueshme.
- / Guxohet të përdoret vetëm materiali i përshtatshëm për përfërim! Vidhat dhe kunjat prezent janë të përshtatshme vetëm për beton.

PËRSHKRIMI I SIMBOLIT



Mos përdorni silikon që në përbërje ka acid acetik.



SHEMBULL INSTALIMI
(shih faqen 18)



PËRMASAT (shih faqen 35)



PJESËT E SERVISIT (shih faqen 34)

PAJISJE TË POSAÇME

(nuk përfshihet në vëllimin e furnizimit)

93941000 (shih faqen 34)

△ تنبيهات الأمان

- △ يجب ارتداء قفازات لليد أثناء التركيب لتجنب حدوث أضرار الإنحشار أو الجروح
- △ لا يجب استخدام المنتج إلا في أغراض الاستحمام والأغراض الصحية وأغراض تنظيف الجسم.

تعليمات التركيب

- / قبل القيام بعملية التركيب، يجب فحص المنتج للتأكد من خلوه من أية تلفيات ناتجة عن النقل بعد القيام بعملية التركيب، لن يتم الاعتراف بوجود أية تلفيات سطحية أو تلفيات ناتجة عن عملية النقل.
- / يجب تركيب وغسيل واختبار التوصيلات وخلطات المياه طبقاً للمعايير السارية.
- / يجب مراعاة القواعد الخاصة بالتركيب وأعمال السباكة وفقاً للوائح الخاصة بكل بلد.
- / يجب أن يتميز السقف المراد تثبيت الدش المعلق به بقدرة تحمل كافية.
- / يسمح باستخدام أدوات الربط المناسبة فقط! تتناسب المسامير اللولبية والسدادات المرفقة مع التثبيت في الخرسانة.

وصف الرمز

هام! لا تستخدم السليكون الذي يحتوي على أحماض!



مثال للتركيب (راجع صفحة 18)



أبعاد (راجع صفحة 35)



قطع الغيار (راجع صفحة 34)



ملحقات خاصة

(غير مدرج مع المحتويات المسلمة)

#93941000 (راجع صفحة 34)



△ GÜVENLİK UYARILARI

- △ Montaj esnasında ezilme ve kesilme gibi yaralanmaları önlemek için eldiven kullanılmalıdır.
- △ Ürün yalnızca banyo, hijyen ve beden temizliği amaçları doğrultusunda kullanılabilir.

MONTAJ AÇIKLAMALARI

- / Montaj işleminden önce ürün nakliye hasarları yönünden kontrol edilmelidir. Montaj işleminden sonra nakliye veya yüzey hasarları için sorumluluk üstlenilmemektedir.
- / Boruların ve armatürün montajı, yıkanması ve kontrolü geçerli normlara göre yapılmalıdır.
- / Ülkelerde geçerli kurulum yönetmeliklerine riayet edilmelidir.
- / Kafa duşunun monte edileceği tavan yeterli taşıma kapasitesine sahip olmalıdır.
- / Sadece uygun sabitleme malzemesi kullanılmalıdır! Ekteki vidalar ve dübeller sadece beton için uygundur.

SİMGE AÇIKLAMASI

Asetik asit içeren silikon kullanmayın!



KURULUM ÖRNEĞİ
(bakınız sayfa 18)



ÖLÇÜLERİ (bakınız sayfa 35)



YEDEK PARÇALAR (bakınız sayfa 34)

ÖZEL AKSESUARLAR
(Teslimat kapsamına dahil değildir)

#93941000 (bakınız sayfa 34)

GARANTİ BELGESİ**ÜRETİCİ VEYA İTHALATÇI FİRMANIN**

Unvanı: Hansgrohe Armatür Ltd. Şti
Adresi: Fulya Mahallesi Bahçeler Sokak Efe han 20/C
Mecidiyeköy Şişli İstanbul
Telefonu: (0-212) 273 07 30
Faks: (0-212) 273 07 40
web adresi: www.hansgrohe.com.tr

MALİN

Markası: Hansgrohe
Cinsi: Sıhhi tesisat malzemesi
Garanti Süresi: 2 YIL
Azami Tamir Süresi: 20 İş günü

GENEL MÜDÜR
Albert Emlek

Satıcı Firmasının:
Unvanı:
Adresi:

Telefonu:
Faks:
e-posta:
Fatura Tarih ve Sayısı:
Marka ve Modeli:
Teslim Tarihi ve Yeri:
Yetkilinin İmzası:
Firmasının Kaşesi:
Bu bölümü, ürünü aldığınız Yetkili Satıcı imzalayacak ve kaşeleyecektir.

MONTAJI
(bakınız sayfa 28)



⚠ BIZTONSÁGI UTASÍTÁSOK

- ⚠ A szerelésnél a zúzódások és vágási sérülések elkerülése érdekében kesztyűt kell viselni.
- ⚠ A terméket csak fürdéshez, mosakodáshoz, és egészségügyi tisztálkodáshoz szabad használni.

SZERELÉSI UTASÍTÁSOK

- / A szerelés előtt ellenőrizni kell, hogy a terméknek nincs-e szállítási sérülése. Beépítés után a szállítási- vagy felületi sérüléseket nem ismerik el.
- / A vezetékeket és a csaptelepet az érvényes szabványoknak megfelelően kell felszerelni, öblíteni és ellenőrizni
- / Az egyes országokban érvényes installációs irányelveket be kell tartani.
- / A mennyezetnek, amelyre a fejuhanyt fel kívánják szerelni, megfelelő teherbíró képességgel kell rendelkeznie.
- / Kizárólag erre a célra való rögzítő anyagokat szabad felhasználni! A mellékelt csavarok és tiplik csak betonhoz használhatók!

SZIMBÓLUMOK LEÍRÁSA

 Ne használjon ecetsavtartalmú szilikont!

 **FELSZERELÉSI PÉLDA**
(lásd a oldalon 18)

 **MÉRETET** (lásd a oldalon 35)

 **TARTOZÉKOK** (lásd a oldalon 34)

 **EGYÉB TARTOZÉK**
(a szállítási egység nem tartalmazza)

9 3 9 4 1 0 0 0 (lásd a oldalon 34)

הערות בטיחות ⚠

- ⚠ יש להשתמש בכפפות בזמן ההתקנה כדי למנוע פציעות וחתכים
- ⚠ המוצר מיועד לשימוש למטרות רחצה, היגיינה ושטיפת הגוף בלבד

הוראות התקנה

- / לפני ההתקנה, בדוק אם נגרמו למוצר נזקים בהובלה / אחרי ההתקנה, לא נכיר בנזקים שנגרמו בהובלה או בנזקים במשטחים
- / חובה להתקין את הצינורות והאביזרים, לשטוף אותם ולבדוק אותם על פי התקנים הישימים
- / צריך לפעול על פי חוקי השרברבות הישימים במדינת ההתקנה
- / לתקרה בה מתקינים את המקלחת העילית צריך להיות חוזק נשיאת עומס מספיק
- / יש להשתמש בחומרי התקנה מתאימים בלבד! הברגים והדיבלים המצורפים מתאימים לבטון בלבד

תיאור הסמל

אסור להשתמש בסיליקון המכיל חומצה אצטית!

דוגמה להתקנה (ראה עמוד 18)

מידות (ראה עמוד 35)

חלקי חילוף (ראה עמוד 34)

אביזרים מיוחדים (הזמנה של פריט אקסטרה)

#93941000 (ראה עמוד 34)



AXOR 460/300 ljet
35277XXX

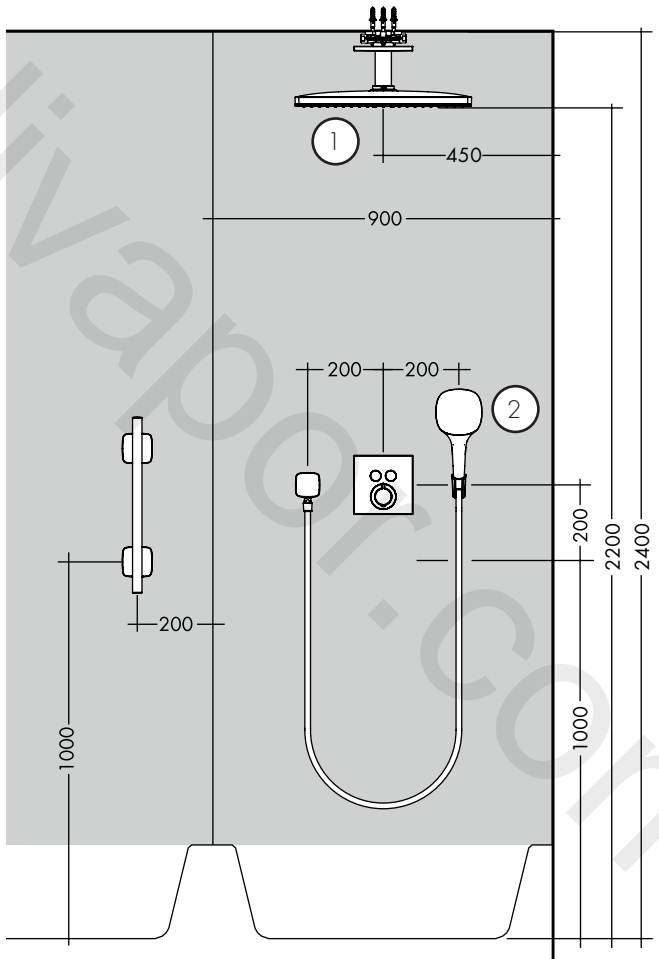
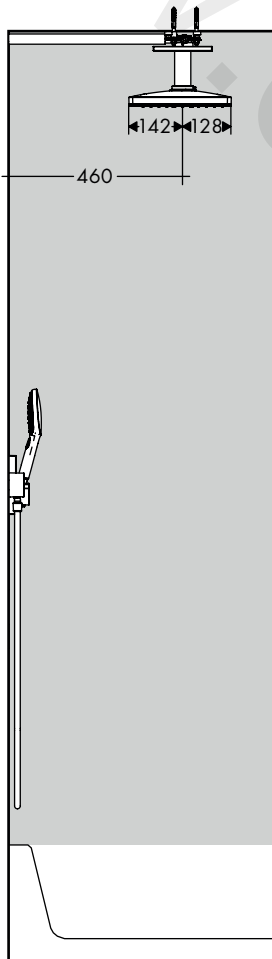
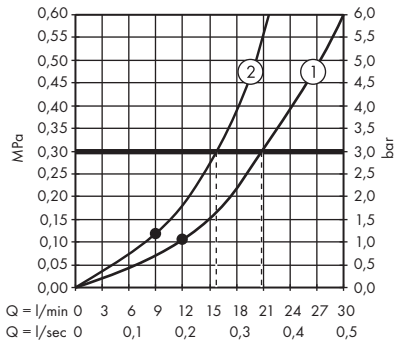



AXOR 460/300 3jet
35281XXX

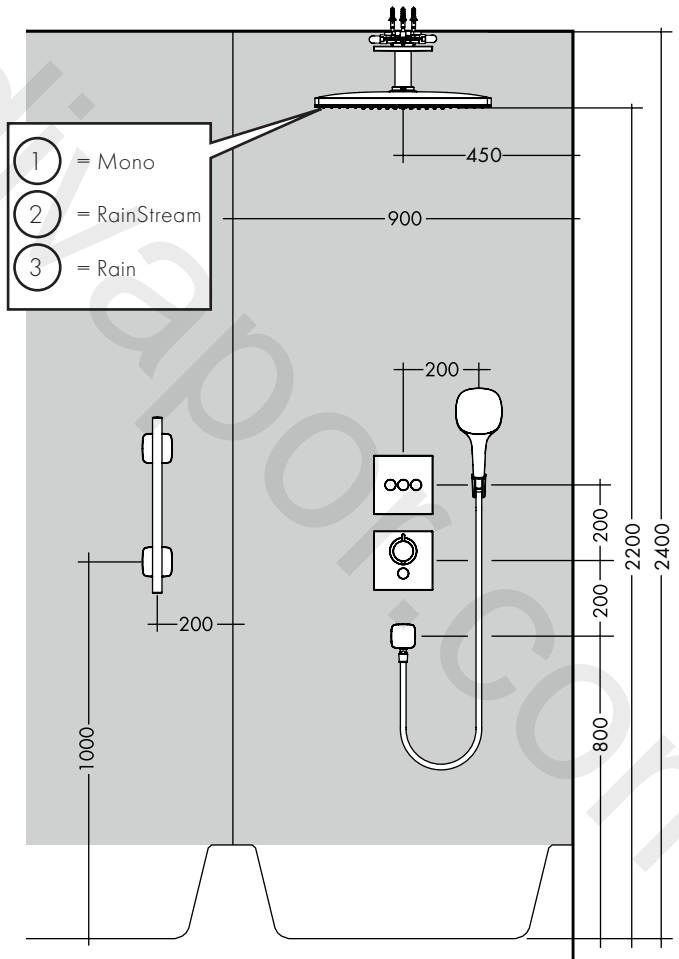
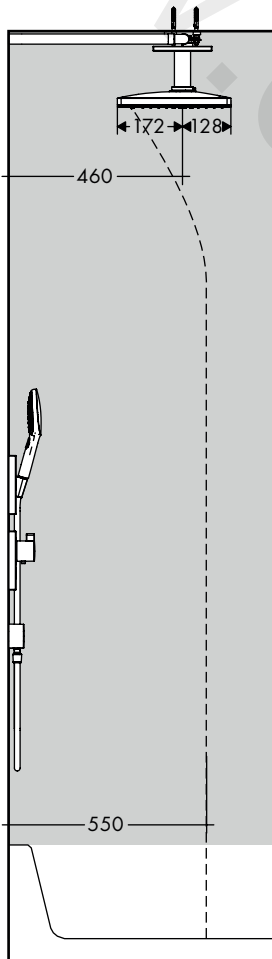
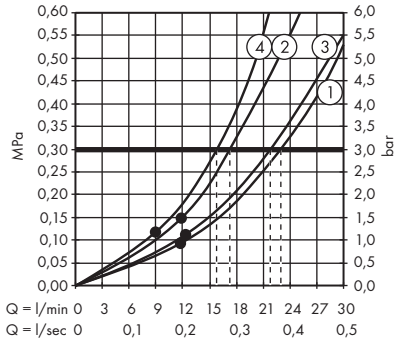

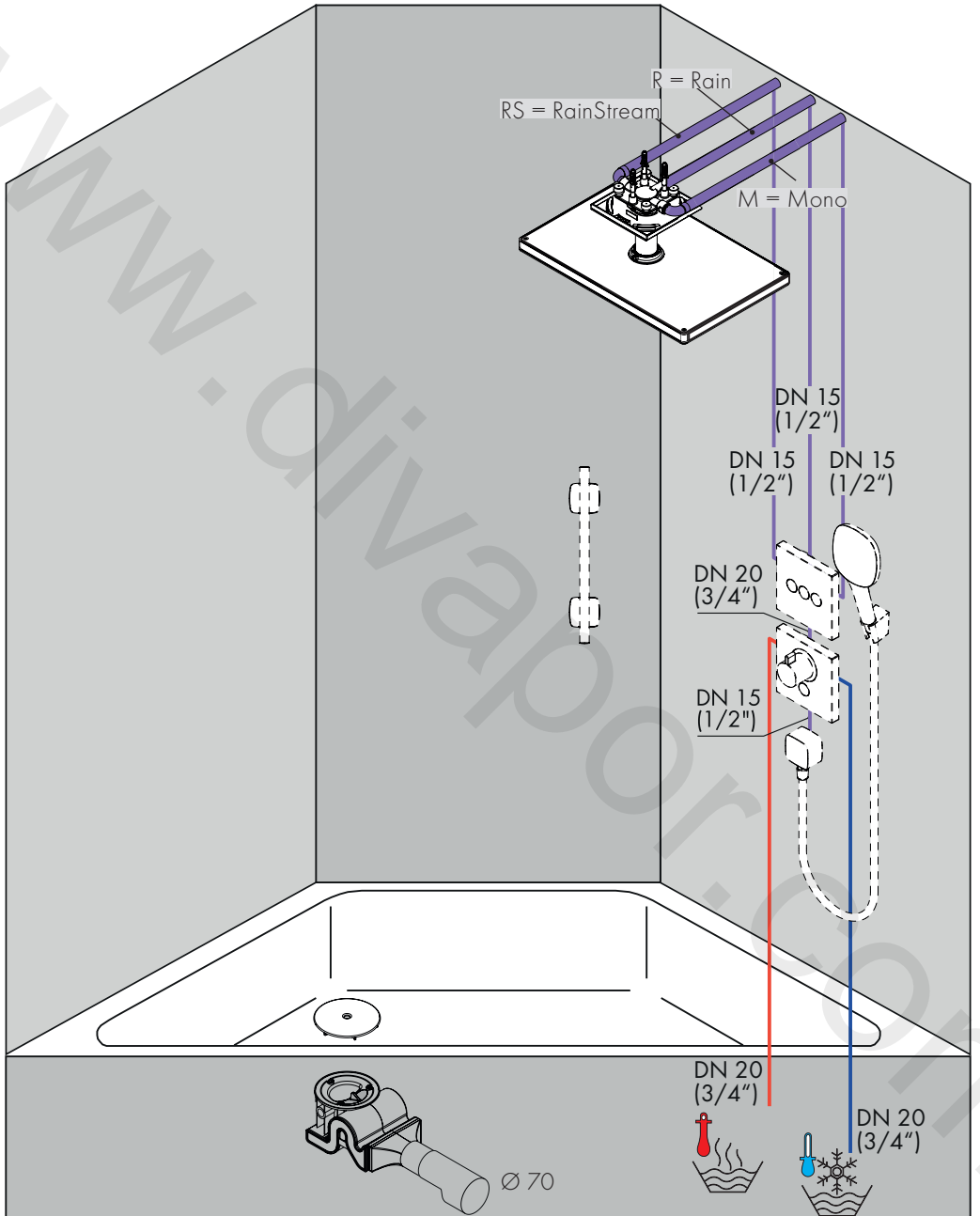

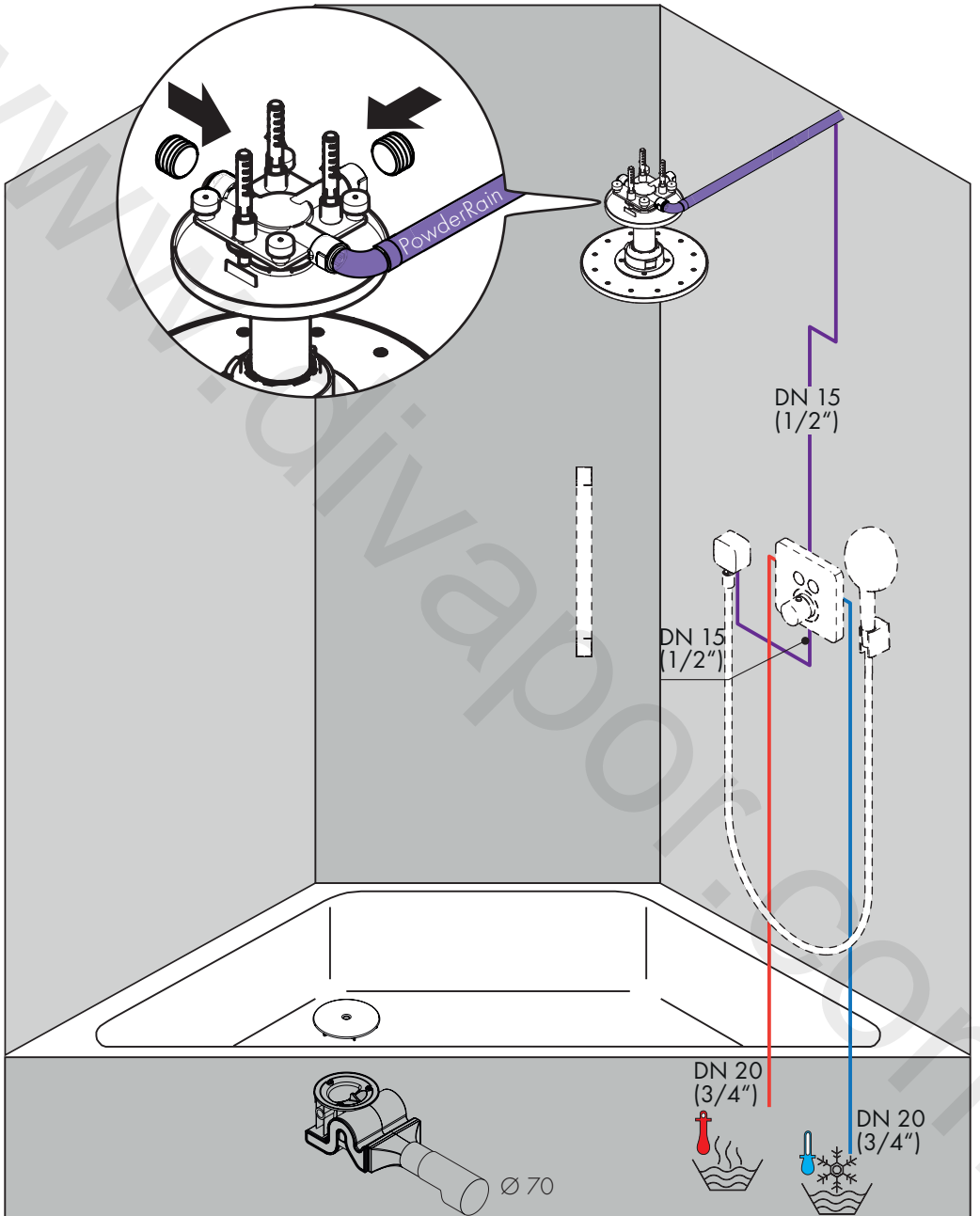

AXOR One 280 2jet
48494XXX

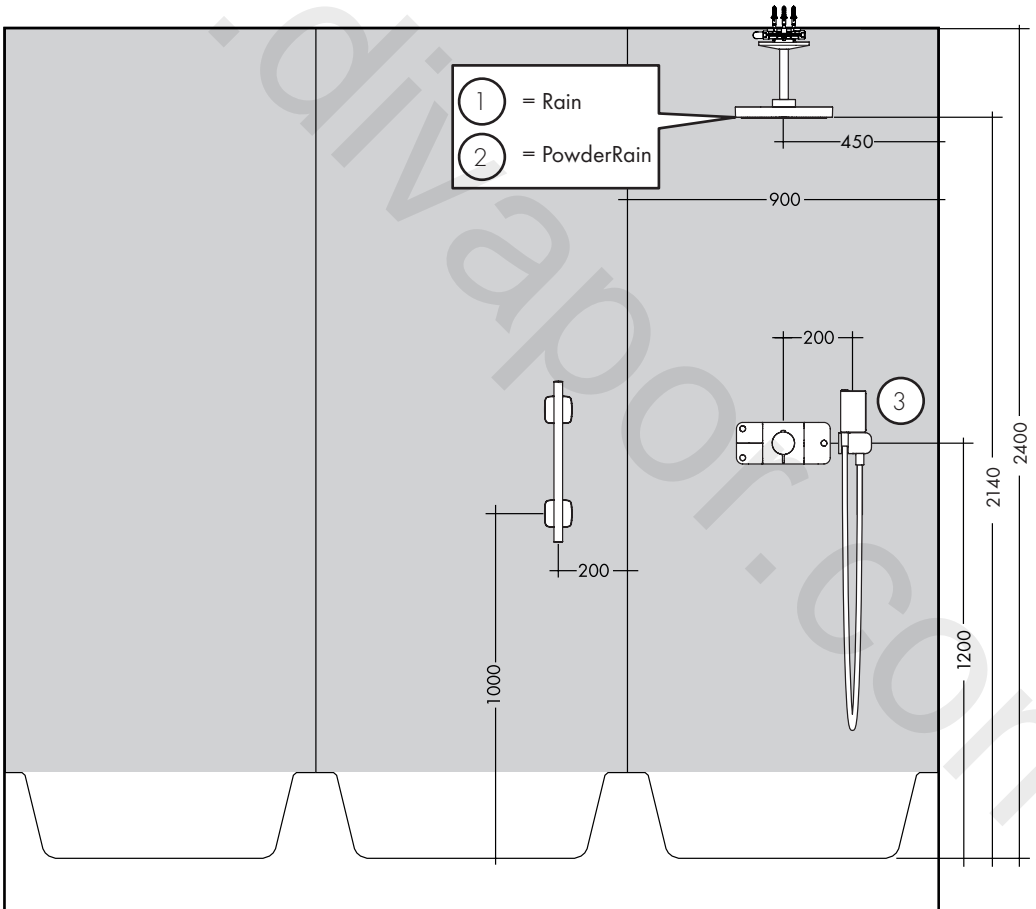
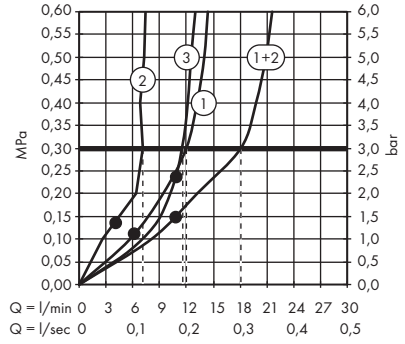

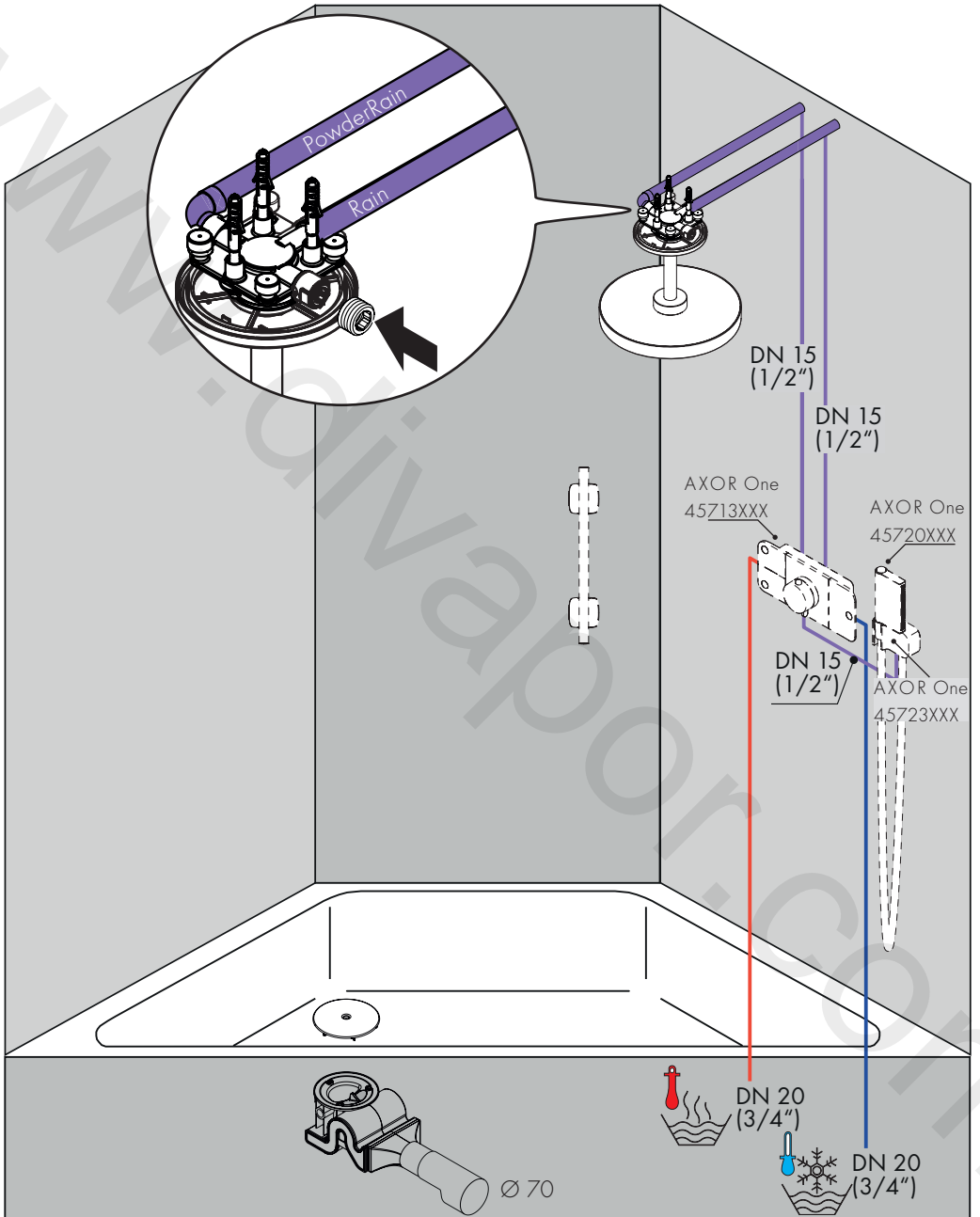

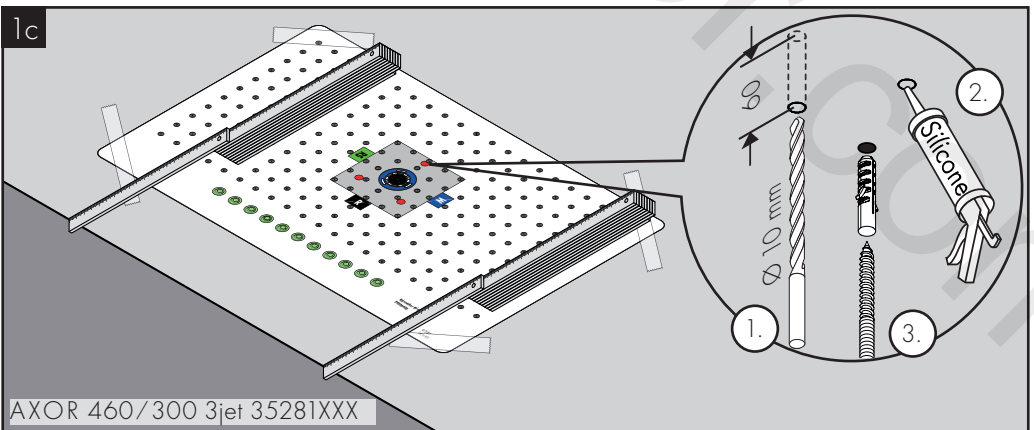
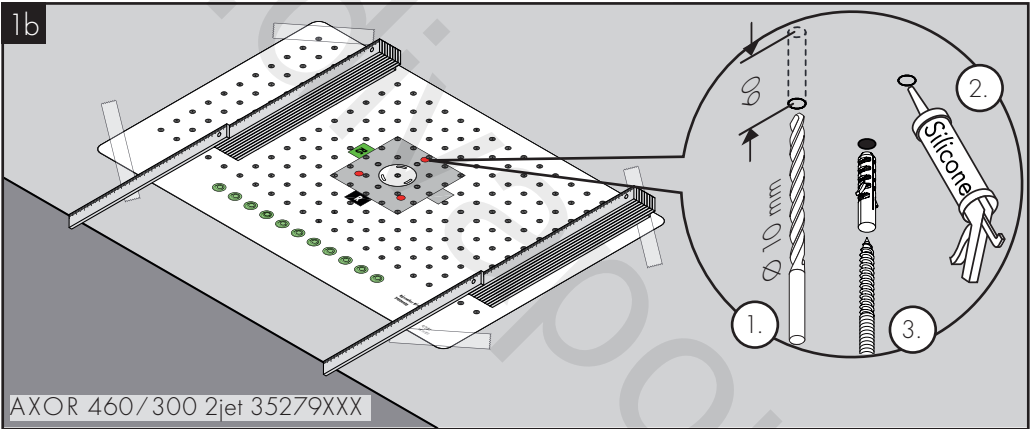
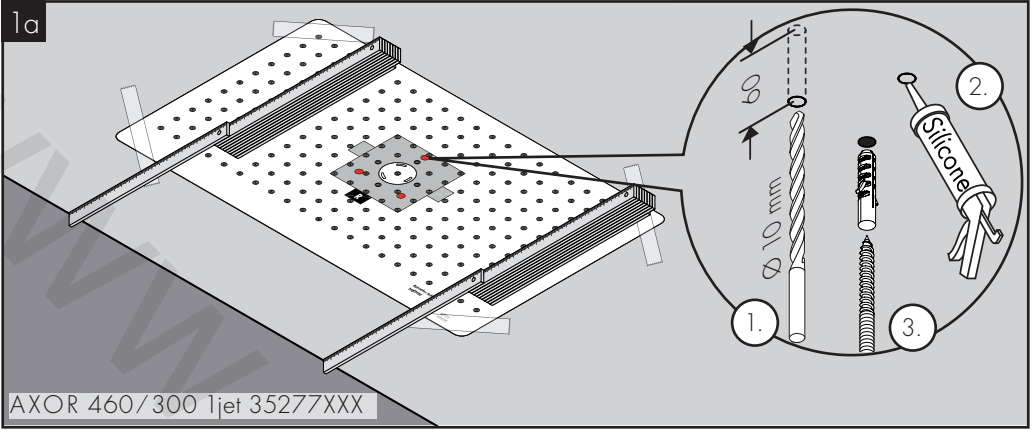

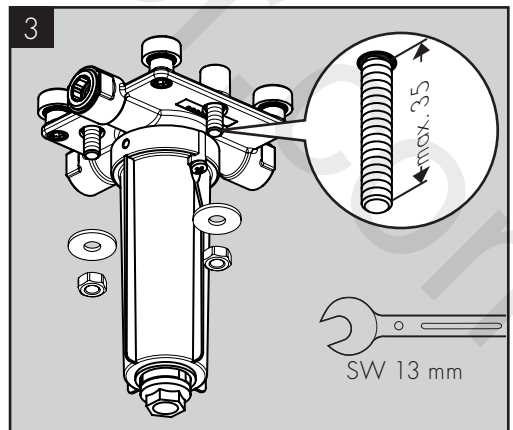
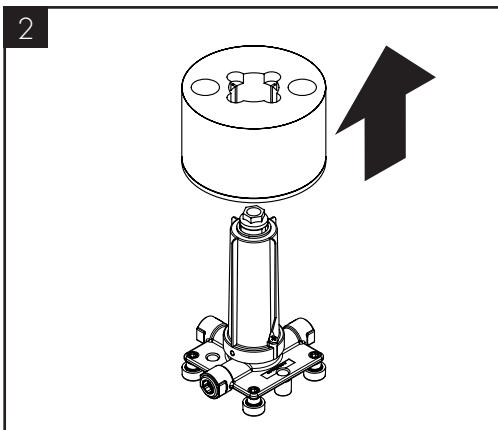
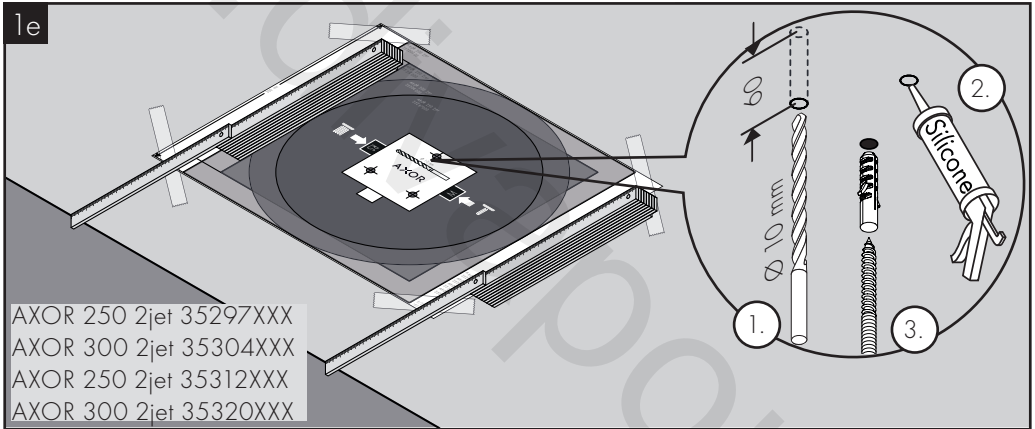
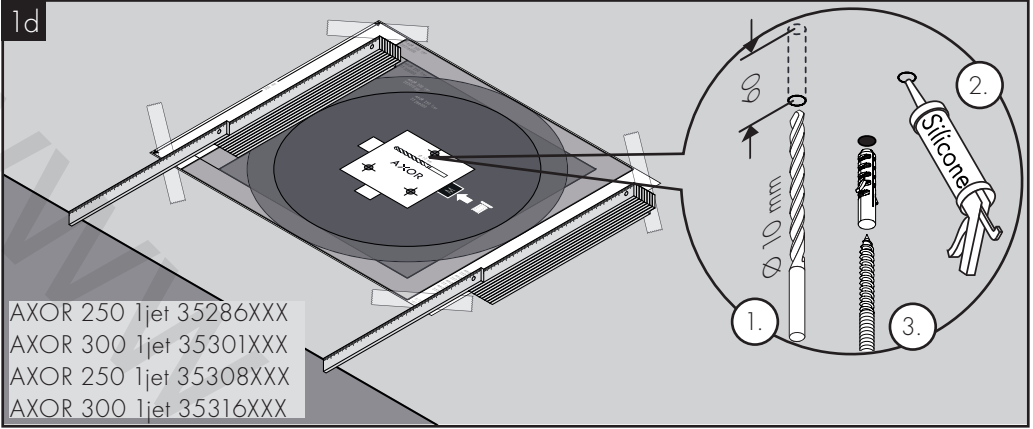

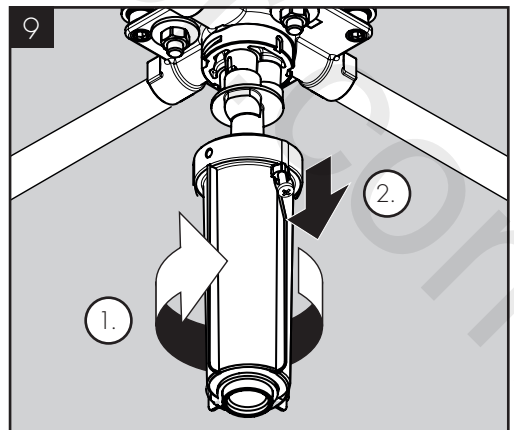
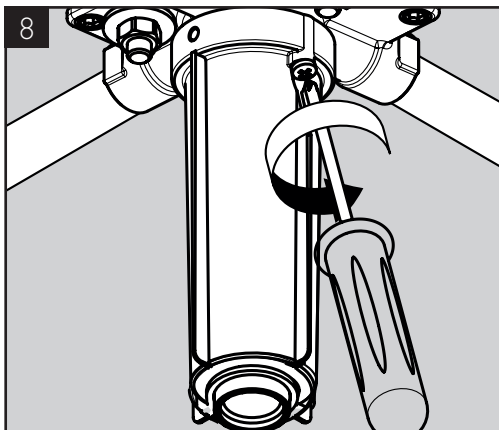
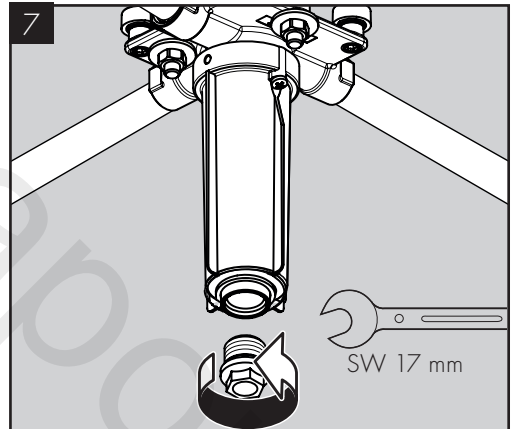
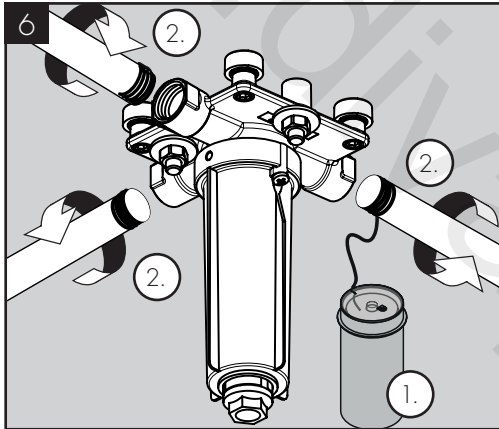
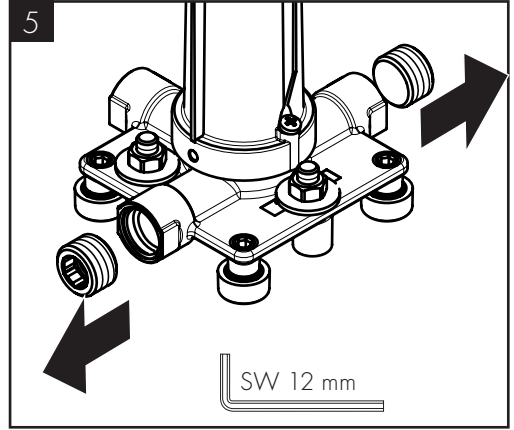
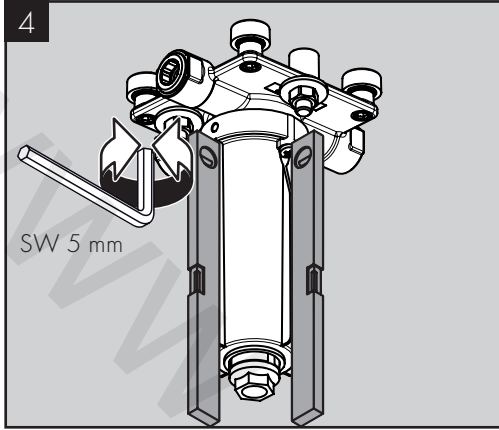

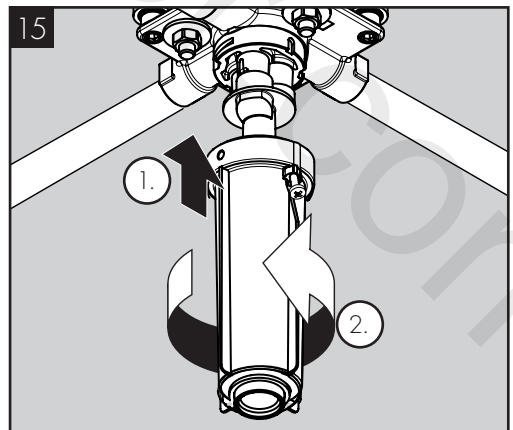
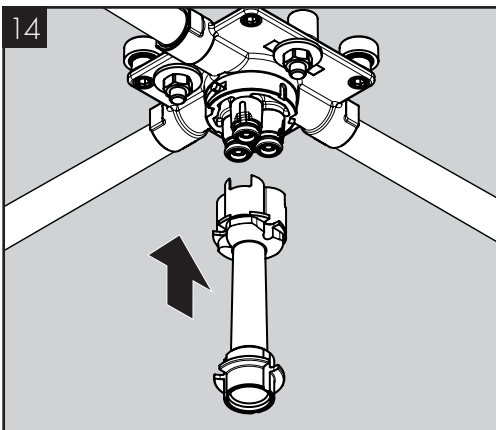
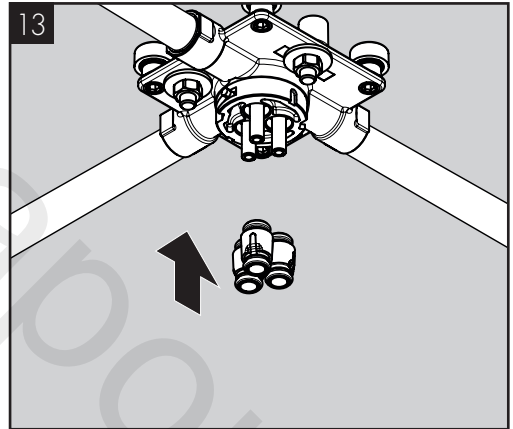
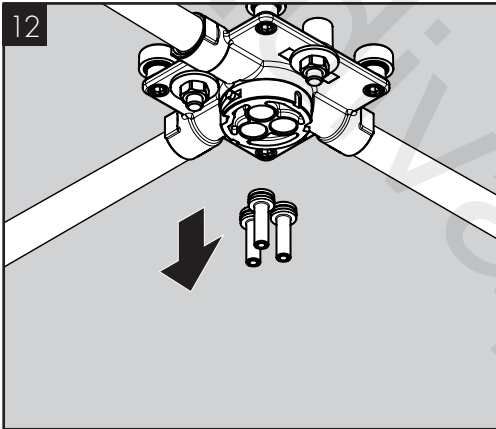
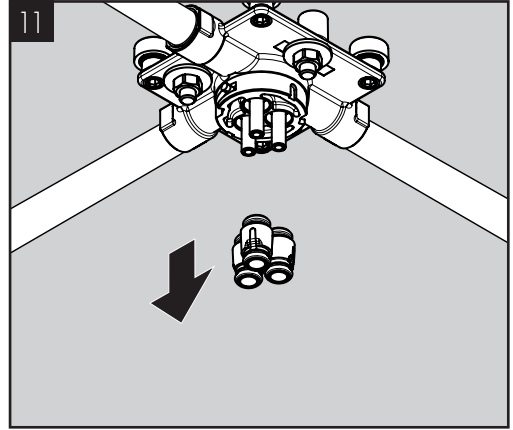
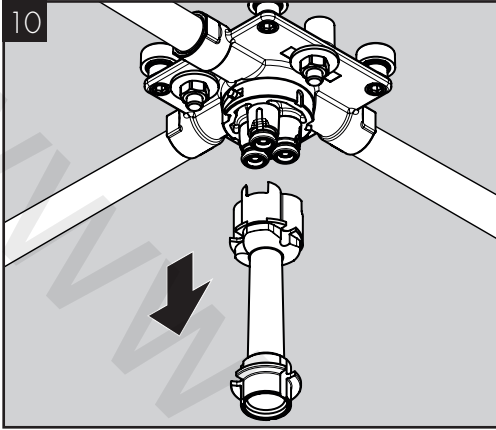

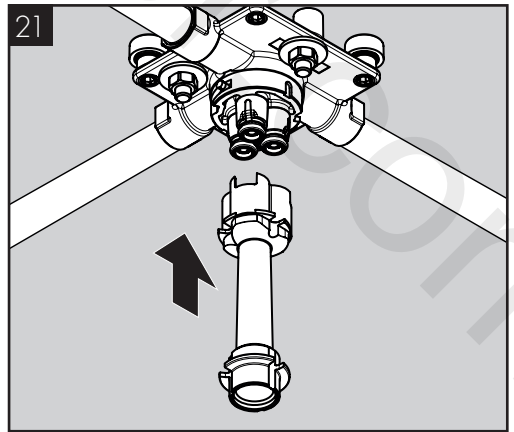
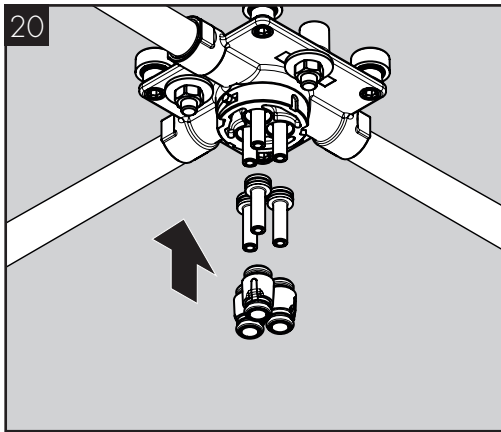
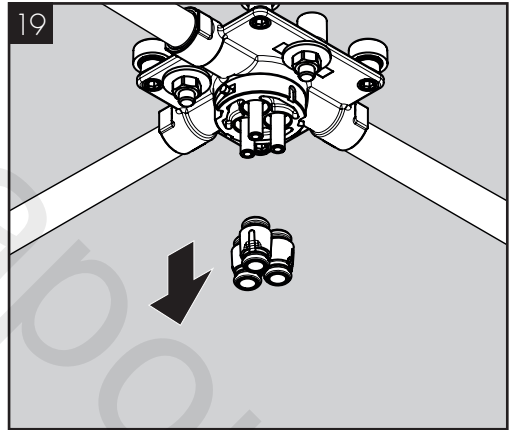
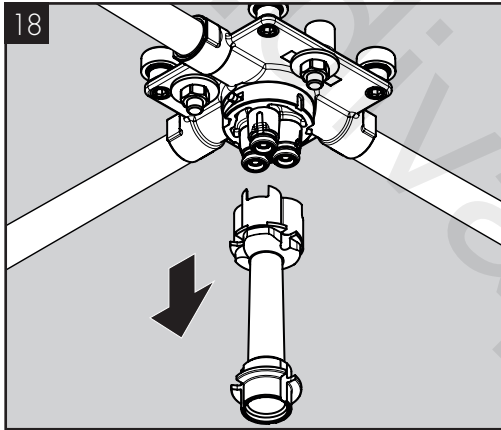
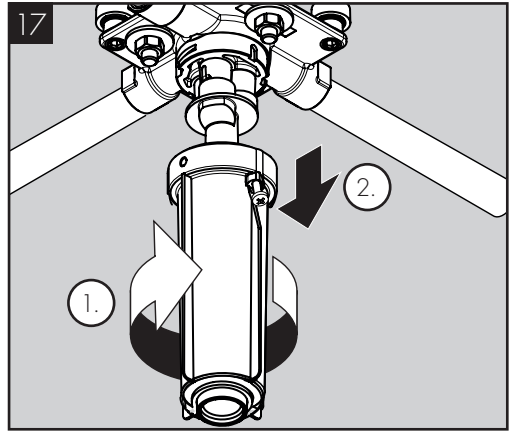
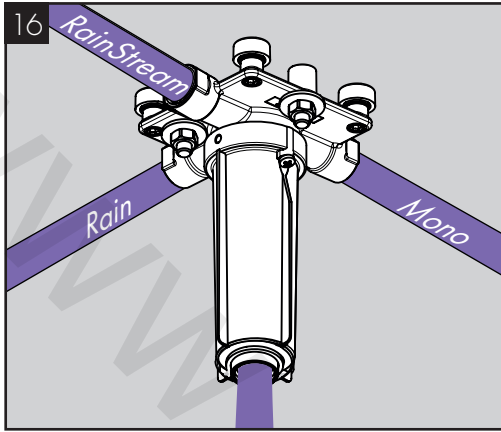

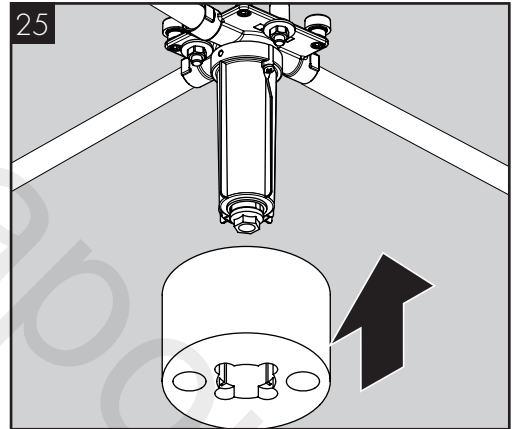
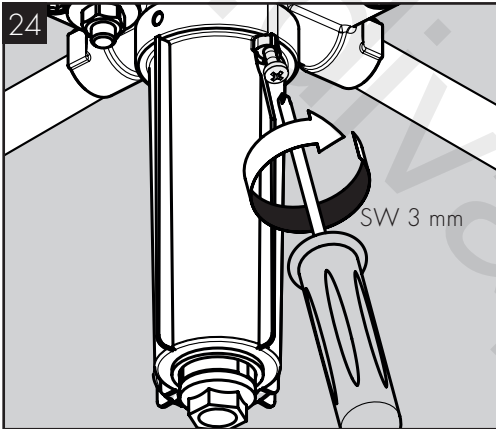
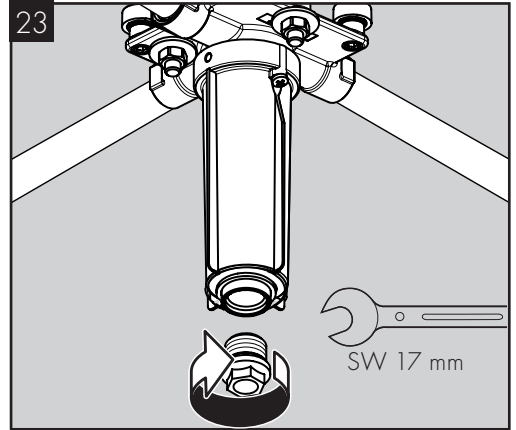
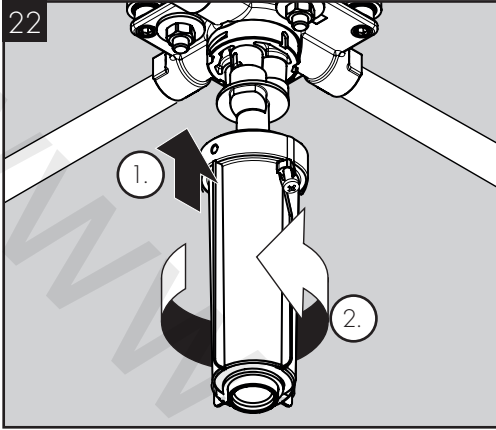

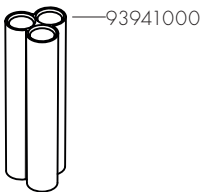
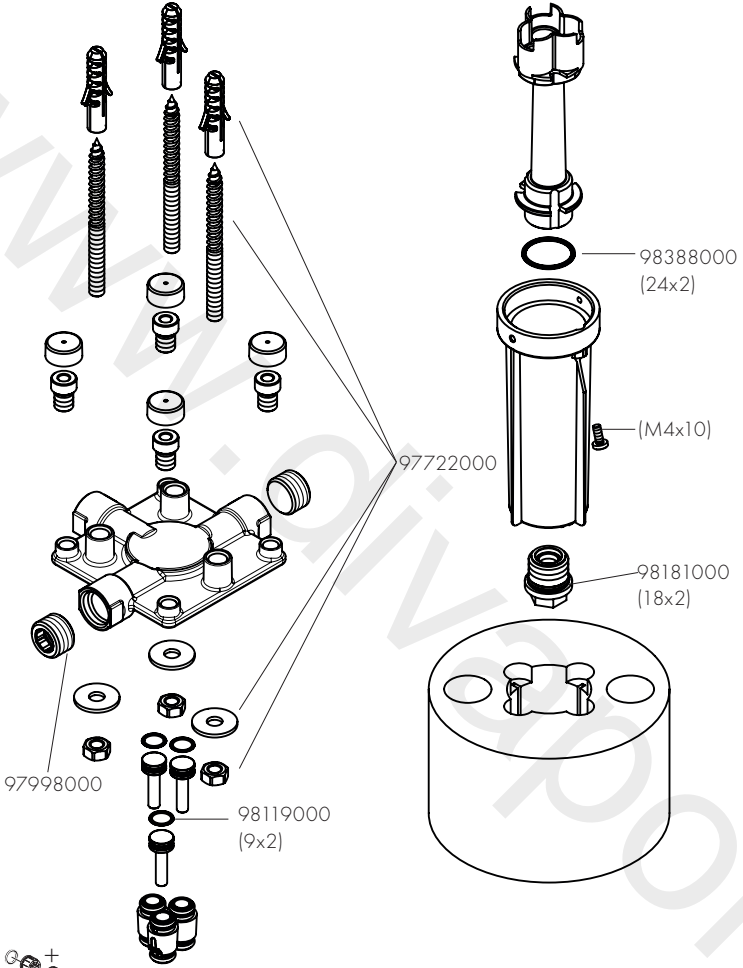

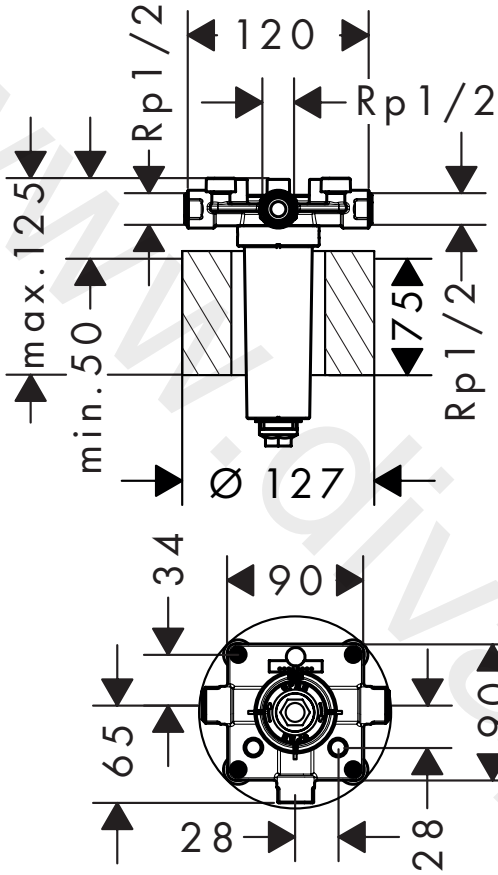

AXOR

www.divapor.com

AXOR / Hansgrohe SE
Austraße 5-9
77761 Schiltach
Deutschland

info@axor-design.com
axor-design.com

01/2023
9.1122703