

ZH 用户手册 / 组装说明 **2**

EN Instructions for use / Assembly instructions **4**

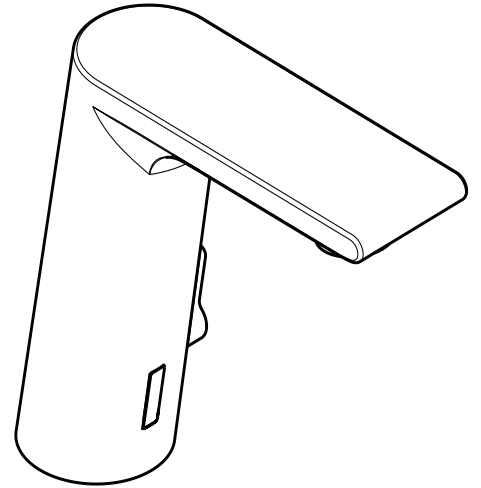

Metris
31100007

www.divapor.com



安全技巧

- △ 装配时为避免挤压和切割受伤, 必须戴上手套。
- △ 本产品只允许作为洗浴, 卫生和洁身之用。
- △ 不得让儿童和肢体, 精神和/或意识有障碍的人在不受监管的情况下使用淋浴系统。受酒精或毒品影响的人员不得使用淋浴系统。
- △ 只有汉斯格雅供应的电池盒及电池 CR-P2 或电源组 HG-Nr. 30589310 可以与管接头的电缆相连。
- △ 受损的电线不允许被替换。那么, 变压器不能再使用。
- △ 变压器包括电源插头除了保护区域都只允许安装或插在干燥的室内。
- △ 变压器不得安装在0或1类保护区域内。
- △ 插座应处于保护区域外。(参见第页 第 6)
- △ 该管接头能够在 2 类保护区域下安装。
- △ 冷热水管间过大的压力差必须予以平衡。

安装提示

- 安装前必须检查产品是否受到运输损害。安装后将不认可运输损害或表面损伤。
- 管道和阀门必须根据通用标准进行安装, 冲洗和检查。
- 请遵守当地国家现行的安装规定。
- 必须为阀门留出足够的维护空间。(至少 200 mm)
- 管接头切不可安装在边缘升高的盥洗槽上。(参见第页 6)
- 第一次使用时或者维护工作之后, 在调节电子设备相对于装置的延时功能性的射程范围时, 可以通过光线反射进行。为此, 需要重新调整电子设备, 该调整是通过电子设备10-15分钟后的自动校准实现的。

电气安装

电气安装人员

- △ 由获得许可的电气专业人员按照 DIN VDE 0100 第701部分 / IEC 60364-7-701 规定, 实施安装和检查工作。

电气连接

- △ 供电: 230 V AC \pm 10 % / 50-60 Hz
- △ 必须通过一个故障电流保护装置 (RCD / FI) 进行保险, 设计电流差 \leq 30 mA。必须定期检查保护装置的功能。
- △ 所有的工作只能在没有电压的状况下进行。其中通过总开关或电源插头可靠断开供电。
- △ 插座应处于保护区域外。(参见第页 6, 第 5)

调节

龙头具有如下功能: 背景减弱和整体式范围调整, 这意味着, 龙头通过传感机构, 自动调整到当地条件 (水盆, 亮度, 反光)。

电池操作

LED指示灯发出必须更换电池的信号。

电池电压 \leq 大约5.5 V: 管接头操作时, 传感器窗口中的LED指示灯闪烁, 水可以继续流出

电池电压 \leq 大约5.5 V: 传感器窗口中的LED指示灯连续闪烁, 水无法再流出, 必须更换电池。

注意! 插入电池后, 管接头在大约30秒里不可启动。需要这个时间用于自我调整。

在更换, 安装, 拆除电池时, 请注意附录 3 第 7.12 章节的 EN 60335-1 的提示。

电源组操作

对于更换电源组, 步骤对应于更换电池。

正常操作

检测区域的范围或者从管接头拆卸开/关点去居于环境光学条件 (例如, 盥洗槽的形状和发光情况和环境照明) 以及带入检测区域的物体的形状, 大小, 速度和反光情况。在正常条件下, 管接头的检测区域或者来自管接头之开/关点的距离大约160至200。灰暗 (例如灰黑色) 物体由于反光能力低, 管接头对它们的检测不足。检测区域的范围或者开/关点的距离可能小于 160 mm。明亮或反光物体由于具有高反光性, 故管接头对它们的检测效果很好。检测区域的范围或者开/关点的距离可能大于200 mm。强光源不得直接照射到管接头的传感器窗口。管接头反射器窗口的水滴或冷凝水可能触发意外水流流动。

红外近接电子装置的范围设置

管接头连接到非常小或高度反光的盥洗槽时, 可能需要使用手动模式开关, 减少红外近接电子装置的范围。可以选择如下两个模式:

- “最大范围” (出厂设置)
- “范围减少” (最大范围减少大约50 mm)

传感器窗口后面的LED发出信号表示, 管接头目前处于哪个模式:

- 管接头闭合时, 快速闪烁 = “范围减小”
- 管接头闭合时, 不闪烁 = “最大范围”

从“最大”变更为“减少” (或反之亦然), 的步骤如下:

- 断开阀门和电池盒或电源件之间的电接头连接。在此期间, 将手短暂伸入传感器窗口的检测区域, 从而排出冷凝水。10 s 后重新插上电。
- LED闪烁表示软件版本 (即, 闪烁一次 = 软件版本 1)
- 等待校准 (LED 指示灯持续闪烁 10 s)
- 用手或者一张白纸, 完全覆盖住传感器窗口 (开始放水, 时长 5 s)
- 重新释放传感器窗口
- LED通过闪烁表示当前激活的模式: 一次 = “最大范围”, 两次 = “范围减小”
- 然后, LED永久闪烁, 直到刚刚设置的红外近接开关的校准已经完成
- 接下来的 10 s 内可以重新设置检测范围
- LED再次熄灭时, 管接头准备操作

技术参数

本龙头配有 EcoSmart (流量限制器)

工作压力:	最大 0,8 MPa
推荐工作压力:	0,1 - 0,5 MPa
测试压强:	1,6 MPa (1 MPa = 10 bar = 147 PSI)
热水温度:	最大 60°C
50 K温差和0,3 MPa流水压力下的最大流出量:	最大 42°C
继续时间:	1 - 2, 秒
自动关闭:	10秒后
电池:	CR-P2 / 6 V 锂
变压器:	230 V AC \pm 10 % / 50 - 60 Hz / 20 mA
保护等级:	IPX5
放置地点 铭牌:	参见第页 12
该产品专为饮用水设计!	

符号说明

 请勿使用含有乙酸的硅胶!

 **max. \approx 38°C** 安全功能 (参见第页 7)

恒温阀芯的安全功能可以预先设定所希望的最高出水温度, 例如最高温度为38°C

 保养 (参见第页 9)

单向阀必须在符合国家或当地的法律的情况下按照EN 806-5定期检查 (至少一年一次)。

 清洗 (参见第页 8)

禁止用高压或蒸汽清洗器清洗龙头。

 清洗水盆 (参见第页 10)

如要短时间事先设置卫生冲洗或网络重置, 仍必须等待约 90 s, 直到能够激活“清洁洗漱盆”。

0, 1, 2 保护区域 (参见第页 6)

 更换电池 (参见第页 10)

 备用零件 (参见第页 12)

 大小 (参见第页 11)

 流量示意图 (参见第页 11)

 操作 (参见第页 7)

Hansgrohe 建议进行卫生冲喷, 早晨或长期停用后不要将头半升水作为饮用水。卫生冲洗装置激活时, 上次操作后, 阀门每 24 h 打开 10 s。

卫生冲喷

执行下列步骤, 激活或禁用卫生冲喷:

- 断开阀门和电池盒或电源件之间的电接头连接。在此期间, 将手短暂伸入传感器窗口的检测区域, 从而排出冷凝水。10 s 后重新插上电。
- LED闪烁表示软件版本 (即, 闪烁一次 = 软件版本 1)
- 等待指示灯熄灭
- 用手或一张白纸将传感器窗口完全遮挡住约 5 s 至 10 s 时间 (开始放水, 时长 5 s)
- 重新释放传感器窗口
- 指示灯闪烁, 表明进入以下工作模式: 1 x = 启动, 2 x = 关闭
- 然后在校准后可以再次更改运行模式
- 上次更改运行模式后的 60 s 后, 阀门才会处于正常运行模式



持续冲喷

如要短时间事先设置卫生冲洗或网络重置, 仍必须等待约 90 s, 直到能够激活持续冲洗.

- 用手或者一张白纸, 完全覆盖住传感器窗口
- 阀门打开约 5 s 并立即再次关闭. 若约 5 s 后阀门再次打开, 必须再次释放传感器窗口.
- 冲喷持续约 180 秒. 可以随时通过接触感应区取消持续冲喷.

热力消毒

- 只允许受过培训的人员按照工作表 DVGW W 551 ($\geq 70^{\circ}\text{C}$ / > 3 min) 进行热力消毒.

- 进行热力消毒时存在烫伤危险.
- 在高温杀菌期间, 冷水管必须处于关闭状态. 然后才能启动“持续冲喷”.

网络重置

网络重置时, 水龙头重新校准.

- 中断水龙头电源
- 短时间进入水龙头视线范围, 便于电容器放电
- 约 10 s 之后重新连接插塞连接
- 后 30 s 期间, 水龙头重新校准, 在此期间, 任何物体不得进入检测范围

www.divapor.com

**Safety Notes**

- ⚠ Gloves should be worn during installation to prevent crushing and cutting injuries.
- ⚠ The product may only be used for bathing, hygienic and body cleaning purposes.
- ⚠ Children as well as adults with physical, mental and/or sensoric impairments must not use this product without proper supervision. Persons under the influence of alcohol or drugs are prohibited from using this product.
- ⚠ Only the battery housing with battery CR-P2 or power pack HG No. 30589310 supplied by Hansgrohe may be connected to the electrical connection cable of the fittings.
- ⚠ A damaged connecting line must not be replaced. The transformer may no longer be used.
- ⚠ The transformer and its mains plug may only be installed or plugged in in dry interior rooms outside of the protected zones.
- ⚠ The transformer must not be installed in protection zones 0 or 1.
- ⚠ The wall socket must be outside of the protected zones. (see page Fig. 6)
- ⚠ The fitting may be installed in protected zone 2.
- ⚠ The hot and cold supplies must be of equal pressures.

Installation Instructions

- Prior to installation, inspect the product for transport damages. After it has been installed, no transport or surface damage will be honoured.
- The pipes and the fixture must be installed, flushed and tested as per the applicable standards.
- The plumbing codes applicable in the respective countries must be observed.
- Leave enough space above the tap for servicing. (min. 200 mm)
- The fittings must not be installed on washstands with raised edge. (see page 6)
- At the start of operation, or after maintenance, function of the faucet may be delayed due to reflections during adjustment of the operating distance. The faucet will automatically calibrate itself. The self-calibration will start after 10-15 minutes.

Electrical installation**Electrician**

- ⚠ The installation and test work must be performed by an authorized electrician under consideration of DIN VDE 0100 part 701 / IEC 60364-7-701.

Electrical connection

- ⚠ Voltage supply: 230 V AC \pm 10 % / 50-60 Hz
- ⚠ The circuit must be protected via a ground fault protector (RCD / FI) with a measured differential current of \leq 30 mA. The proper function of this protective device must be checked at regular intervals.
- ⚠ Any work may only be carried out in a de-energized state. Here, the voltage supply must be safely separated via the main switch or mains plugs.
- ⚠ The wall socket must be outside of the protected zones. (see page 6, Fig. 5)

Adjustment

This mixer has the following feature: background fade-out with integrated range adjustment, that means the mixer is automatically adjusted on to the local conditions (washbasin, brightness, reflection) by the sensory mechanism.

Battery operation

The indicator LED signals that the battery must be changed.

Battery voltage \leq approx. 5.5 V: The indicator LED in the sensor window blinks when the fitting is operated, water withdrawal continues to be possible

Battery voltage \leq approx. 5.5 V: The indicator LED in the sensor window lights continuously, water withdrawal is no longer possible, the battery must be replaced.

Attention! After insertion of the battery, the fitting should not be activated for approx. 30 seconds. This time is required for self-adjustment.

Replacement, installation and disposal of batteries is subject to the regulations specified in EN 60335-1 Appendix 3 Section 7.12.

Power supply pack operation

For the replacement of a power supply pack, the procedure corresponds to the replacement of a battery.

Normal operation

The range of the detection area or the removal of the switch-on/off point from the fittings depends on the ambient optical conditions (for example, the shape and reflection of the washstand and the ambient light) as well as on the shape, the size, the speed and the reflection of the object that was brought into the detection area. The detection area of the fittings or the distance of the switch-on/off point from the fittings is approx. 160 to 200 mm in normal operation. The detection of dark (for example grey-black) objects by the fittings is inadequate because of their low reflection. The range of the detection area or the distance of the switch-on/off point can be smaller than 160 mm. The detection of bright or reflecting objects by the

fittings is very good as a result of their high reflectivity. The range of the detection area or the distance of the switch-on/off point can be greater than 160 mm. Strong light sources should not shine directly on the sensor window of the fittings. Drops of water or condensed water on the sensor window of the fittings can initiate unintended running of the water.

Range setting for infrared proximity electronics

It may be necessary to reduce the range of the infrared proximity electronics by manual mode switching when the fittings are connected to very small or highly reflecting washstands. The following two modes can be selected:

- Maximum range (factory setting)
- Reduced range (maximum range reduced by approx. 50 mm)

The LED behind the sensor window signals which mode the fittings are currently in:

- Short blinking when the fittings are closed = "reduced range"
- No blinking when the fittings are closed = "maximum range"

Perform the following steps to change from "maximum" to "reduced" range or vice versa:

- Disconnect electrical plug connection between fitting and battery housing or power pack. During this time, briefly reach with your hand into the detection area of the sensor window so that the capacitor discharges. Restore the power connection after 10 s.
- The LED blinks to indicate the software version (e.g. blinking once = software version 1)
- Wait for calibration to finish (The light emitting diode lights continuously for 10 s)
- Cover sensor window completely with your hand or a white piece of paper (Water output starts for 5 s)
- Uncover the sensor window
- The LED indicates the currently activated mode by blinking: Once = "maximum range", twice = "reduced range"
- The LED then lights permanently until the calibration of the just set range of the infrared proximity switch has completed
- Range setting can be repeated within the next 10 s
- When the LED goes off again, the fittings are ready for operation

Technical Data**This mixer series-produced with EcoSmart (flow limiter)**

Operating pressure:	max. 0,8 MPa
Recommended operating pressure:	0,1 - 0,5 MPa
Test pressure:	1,6 MPa (1 MPa = 10 bar = 147 PSI)
Hot water temperature:	max. 60 °C
Maximum flowing-out temperature at 50 K temperature difference and 0,3 MPa flow pressure:	max. 42 °C
Follow-up time:	1 - 2, s
Automatic switching-off:	after 10 s
battery:	CR-P2 / 6 V Lithium
transformer:	230 V AC \pm 10 % / 50 - 60 Hz / 20 mA
Protection category:	IPX5
installation site of type plate:	see page 12
The product is exclusively designed for drinking water!	

Symbol description

 Do not use silicone containing acetic acid!

max. \approx 38 °C **Safety Function** (see page 7)

The desired maximum temperature for example max. 38 °C can be pre-set thanks to the safety function.

 **Maintenance** (see page 9)

The check valves must be checked regularly according to EN 806-5 in accordance with national or regional regulations (at least once a year).

 **Cleaning** (see page 8)

Never use high pressure cleaners or steam cleaners to clean the fittings.

 **Cleaning washbasin** (see page 10)

After setting the parameters for the hygiene rinse or making a net reset, wait for approx. 90 s before you can enable the "Clean wash basin" function.

0, 1, 2 Protected area (see page 6)

 **Exchange battery** (see page 10)

 **Spare parts** (see page 12)

 **Dimensions** (see page 11)



Flow diagram (see page 11)



Operation (see page 7)

Hansgrohe recommends not to use as drinking water the first half litre flowing from the tap in the morning, after the hygiene rinse is enabled, or after prolonged non-use. If the fitting opens again after approx. 5 s, the viewing window must be uncovered.

Hygiene rinse

To enable or disable the hygiene rinse, proceed as follows:

- Disconnect electrical plug connection between fitting and battery housing or power pack. During this time, briefly reach with your hand into the detection area of the sensor window so that the capacitor discharges. Restore the power connection after 10 s.
- The LED blinks to indicate the software version (e.g. blinking once = software version 1)
- wait for LED to go out
- Cover the sensor window completely with your hand or a white piece of paper for 5 s - 10 s. (Water output starts for 5 s)
- Uncover the sensor window
- the currently enabled mode is indicated by the flashing of the LED: 1 x = enabled, 2 x = disabled
- A subsequent change of operating mode is possible again after calibration
- The fitting only returns to normal operation 60 s after the last change of operating mode

Permanent rinse

After setting the parameters for the hygiene rinse or making a net reset, wait for approx. 90 s before you can enable the "Permanent rinse" function.

- cover sensor window completely with your hand or a white piece of paper
- The fitting opens for approx. 5 s and immediately closes again. If the fitting opens again after approx. 5 s, the viewing window must be uncovered.
- Permanent rinse is enabled for approx. 180 s and can be interrupted at any time by a movement in the field of vision.

Thermal disinfection

- Thermal disinfection pursuant to process sheet DVGW W 551 ($\geq 70^\circ\text{C}$ / > 3 min) must only be carried out by qualified personnel.
- Risk of scalding with thermal disinfection!
- The cold water feed must be locked during thermal disinfection. Afterwards, "Permanent rinse" can be enabled.

Net reset

A net reset causes the fittings to re-adjust.

- Interrupt the voltage supply to the fittings
- Briefly reach into the field of vision of the fittings to cause the capacitor to discharge
- Wait for approx. 10 s, then plug the connectors in again
- The fittings will re-adjust during the next 30 s. Do not reach into the field of vision during this period of time.

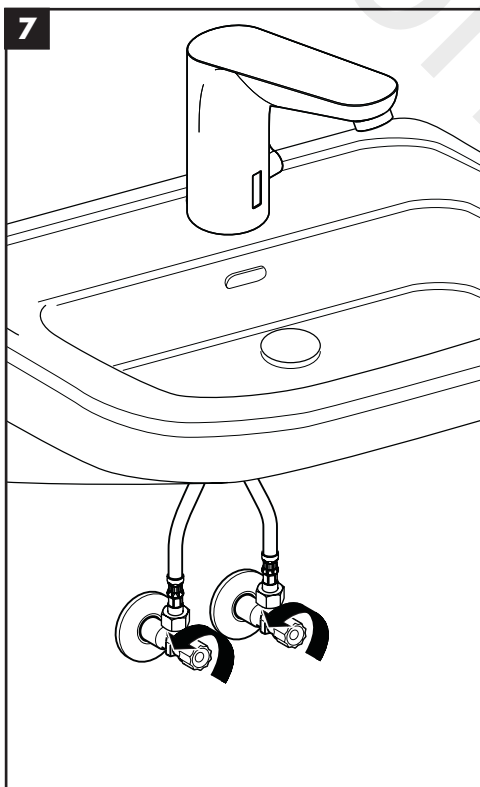
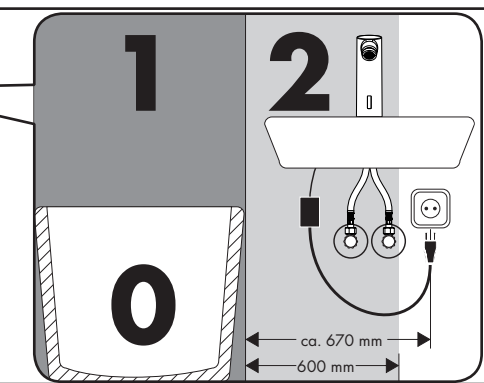
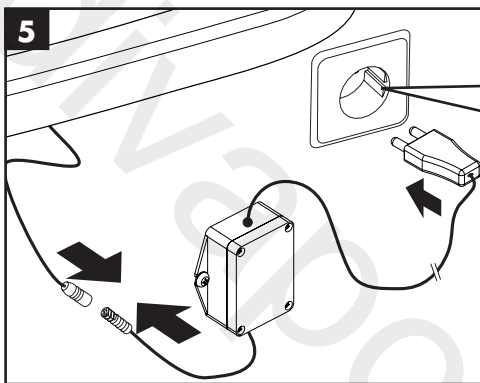
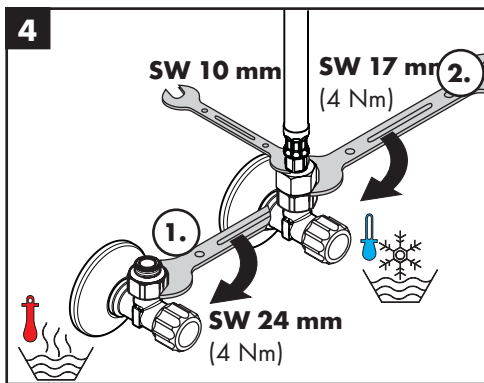
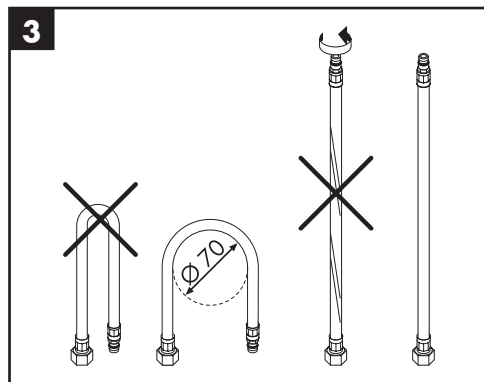
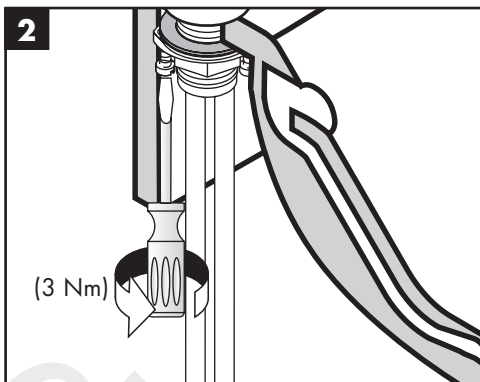
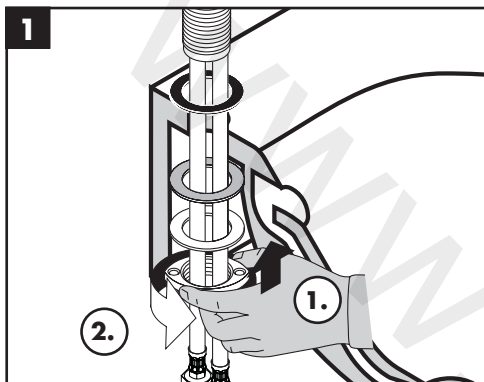
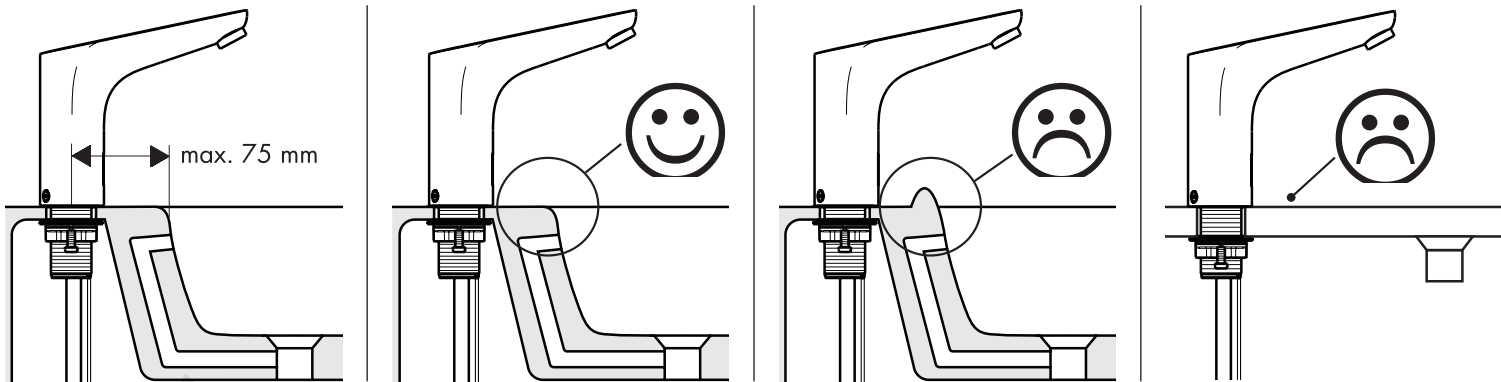

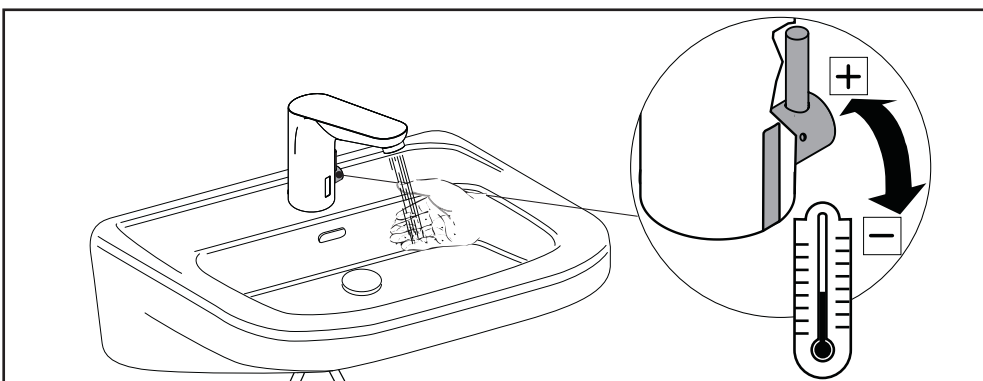
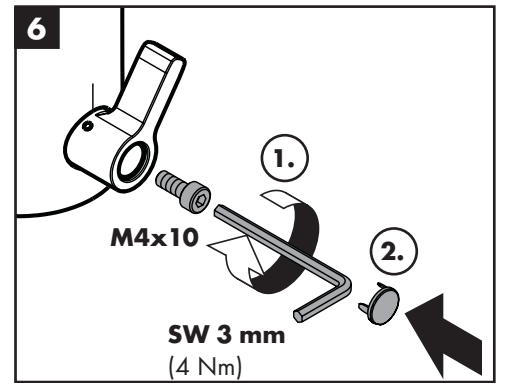
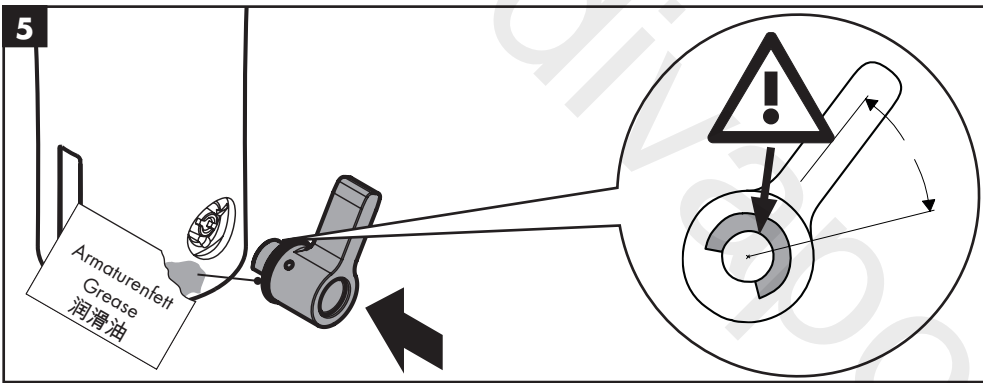
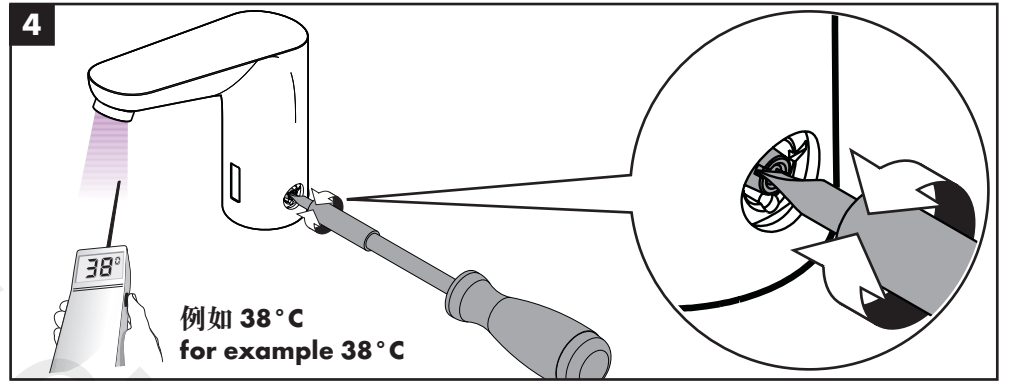
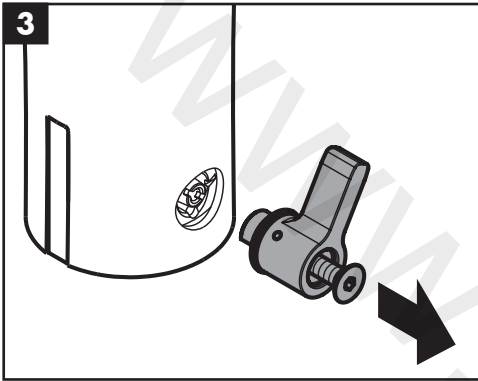
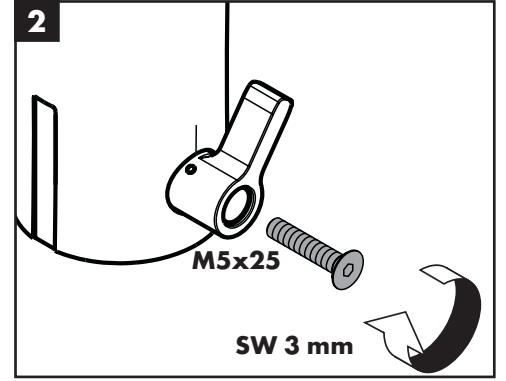
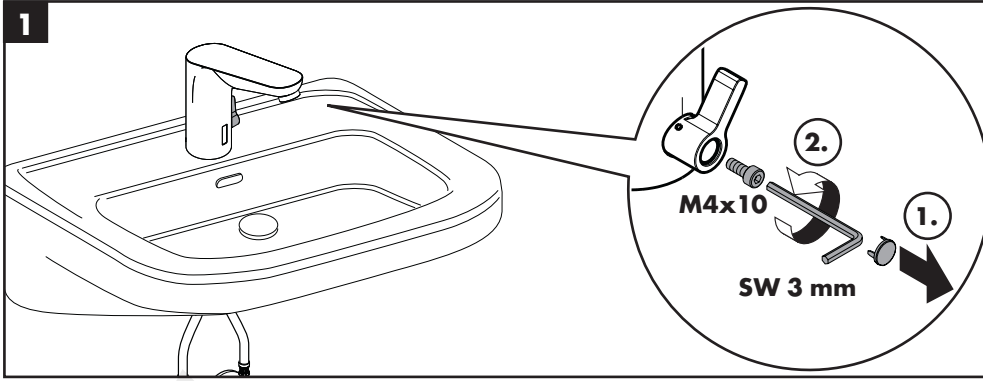

**汉斯格雅产品的清洁建议**

现代的卫浴龙头, 厨房龙头, 花洒, 配件, 盥洗台, 浴盆和加热器采用的制造材料非常迥异, 以适应产品外形设计和使用寿命的市场需求。为了避免产品损坏和由此引发的投诉及争议, 必须在使用和清洁产品时遵循有关规程。

在保养汉斯格雅产品时, 原则上必须注意:

- 只能使用那些有明确注明是适用于本产品的清洁剂。
- 不允许使用含有盐酸, 蚁酸, 氯漂或醋酸的清洁剂, 因为这些清洁剂会给产品表面造成严重的损伤。
- 含磷酸的清洁剂必须在特定条件下使用。
- 不允许将两种以上清洁剂混合使用。
- 不允许使用具有研磨作用的清洁工具和设备, 如不适合的清洁粉末, 海绵垫或超细麦克布。
- 必须严格遵守清洁剂生产厂商的使用说明。
- 严格遵守清洁剂的用量和作用时间, 决不允许清洁剂的作用时间长于规定值。
- 定期的清洁以预防水垢。
- 不允许将清洁剂直接喷射到汉斯格雅产品上, 因为喷雾会进入汉斯格雅产品的开口部分和缝隙中而造成损害。首先将清洁剂喷在软布上, 再用软布进行清洁。
- 清洁之后必须用足够的水冲洗, 以彻底去除残留的吸附物(清洁剂)。
- 不允许使用蒸汽清洗机, 高温会损害产品。

重要说明

肥皂, 洗发水, 沐浴液, 染发剂, 香水, 刮胡水, 指甲油的残留也会对产品造成损伤。

此处: 使用后要小心地用清水将剩余物冲洗干净。

同样在产品下方不得存放洗涤剂 and 化学药品, 例如不可放在用于洗脸盆的梳洗柜中否则挥发气体将损坏产品。

在已经损伤的表面继续使用清洁剂会给表面造成更大的损伤。

表面损坏的部件必须更换, 否则会有受伤的危险。



不按规定进行清洁而造成的任何损坏不在本公司产品保修范围之内。

担保

Hansgrohe 向用户保证, 该产品无制造缺陷。如果自购买之日起五年内出现缺陷, Hansgrohe 将免费排除。保证条件和详情见 www.hansgrohe-int.com/guarantee。在提出保修的权利时请联系您的合同方。本保证不涉及有关国家法律规定的消费权。

QuickClean

有了QuickClean, 手工清洁功能, 要去掉喷头上的水垢, 只需简单地搓除即可。

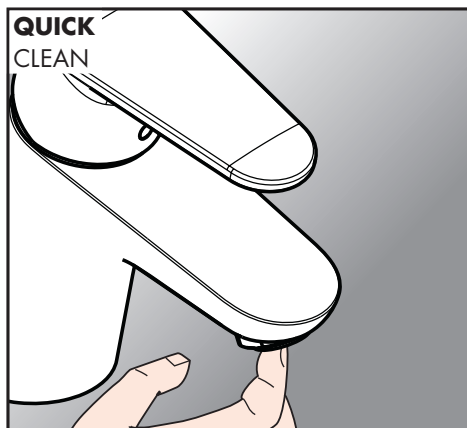
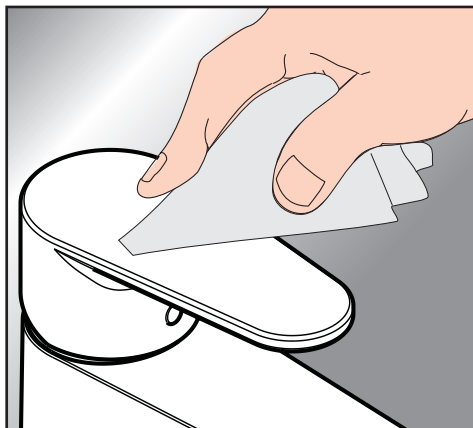
**Cleaning Recommendation for Hansgrohe Products**

Today, modern sanitary and kitchen tapware, showers, accessories, washstands, tubs and radiators consist of very different materials to comply with the needs of the market with regard to design and functionality.

To avoid damage and reclamations, it is necessary to consider certain criteria when cleaning.

With regard to caring for the Hansgrohe products, the following must in principle be heeded:

- Only use cleaning material which is explicitly provided for this type of application.
- Never use cleaning materials, which contain hydrochloric acid, formic acid, chlorine pale lye or acetic acid, as they cause considerable damage.
- Phosphorus acidic cleaners are only conditionally applicable.
- Mixing cleaning agents is not permitted, generally.
- Never use cleaning materials or appliances with an abrasive effect, such as unsuitable cleaning powders, sponge pads or micro fibre cloths.
- The instructions of the cleaning agent manufacturers have to be followed absolutely.
- Cleaning has to be carried out with a specified cleaner dosage, contact time, object-related and adapted to the needs.
- The building up of calcifications has to be removed by cleaning regularly.
- When using spray cleaners, spray the cleaning solution onto a soft cloth or sponge, never directly onto the Hansgrohe products, as the atomised spray could enter openings and gaps in the Hansgrohe products and cause damage.
- After cleaning rinse thoroughly with clean water to remove any cleaner residue.
- The use of steam cleaners is not permitted. The high temperatures can damage the products.

Important

Residues of toiletries such as liquid soaps, shampoos and shower gels, hair dyes, perfumes, aftershave and nail varnish can also cause damage.

Here too: Carefully rinse with water after use to remove residues.

Likewise, do not store any cleaning agents or chemicals under the products, for example in a vanity unit, as the vapours may damage the products.

The damage of already damaged surfaces will deteriorate under the effect of the cleansers.



Components with damaged surfaces must be exchanged, otherwise there could be an injury danger.

Damage caused by improper treatment will not be covered by our guarantee.

Warranty

Hansgrohe guarantees to the consumer that this product is free of production faults. If nevertheless any defect is detected within 5 years from date of purchase, Hansgrohe will remedy this defect free of charge. You will find the conditions and details of this guarantee at www.hansgrohe-int.com/guarantee. Please contact your contracting party to claim your rights under this guarantee. This guarantee does not affect the customer's rights under the respective national legislation.

QuickClean

The QuickClean cleaning function only needs a small manual rub over to remove the lime scale from the spray channels.

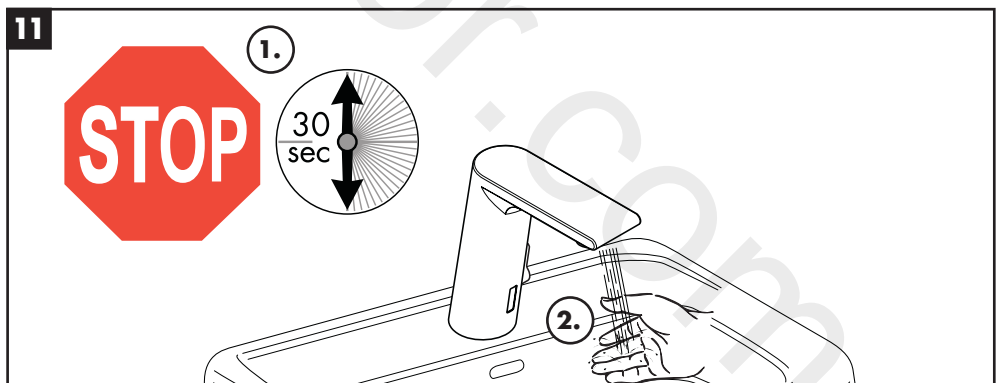
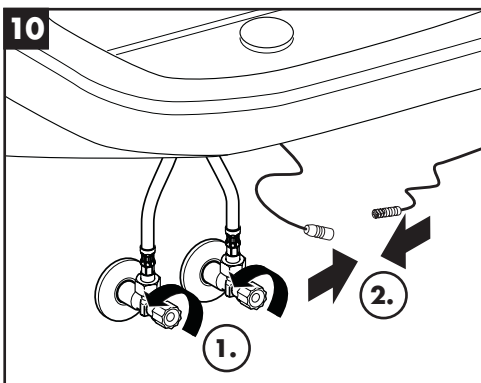
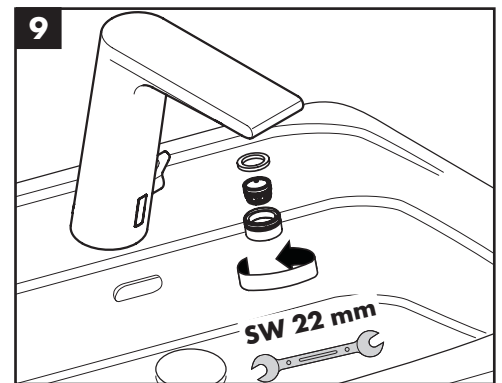
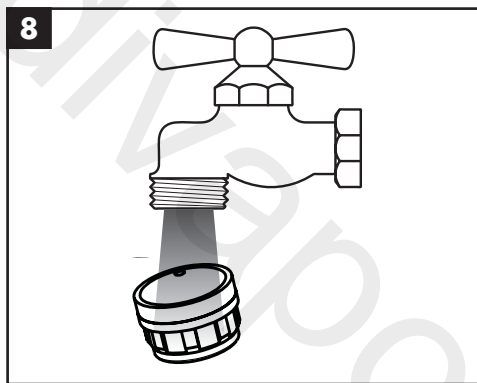
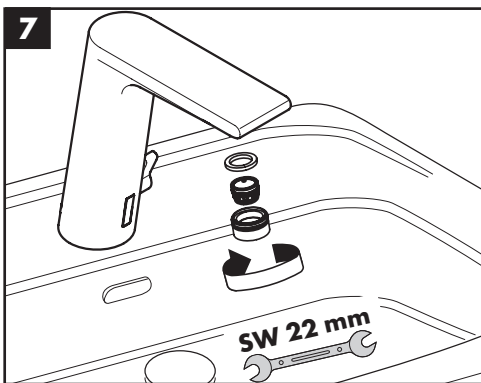
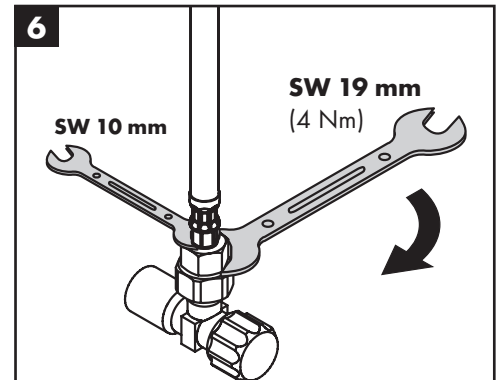
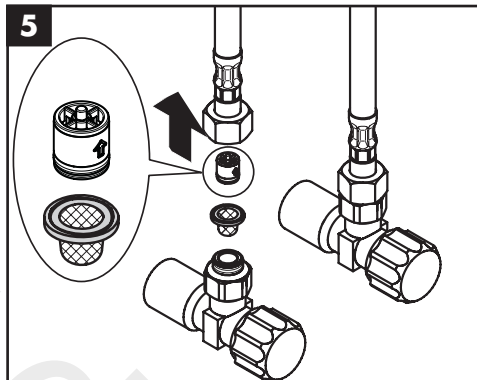
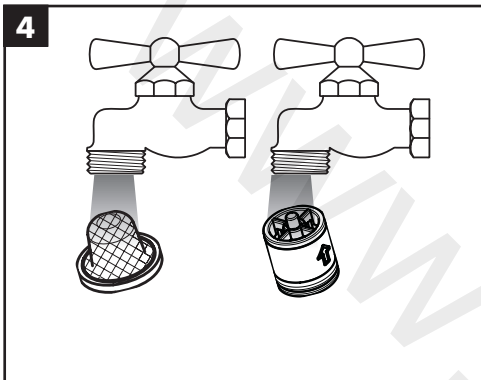
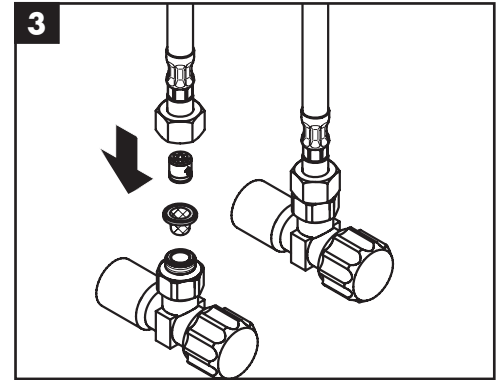
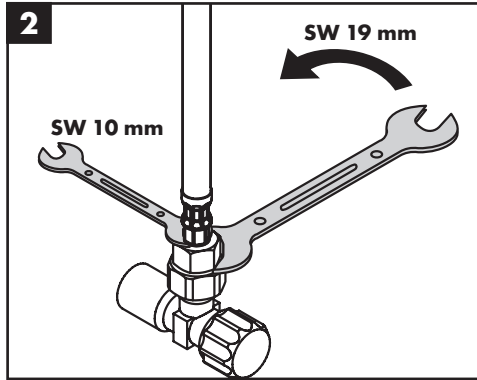
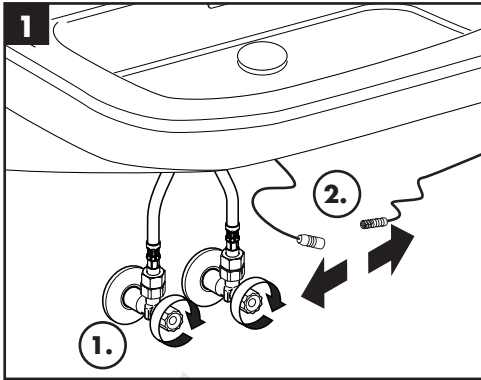

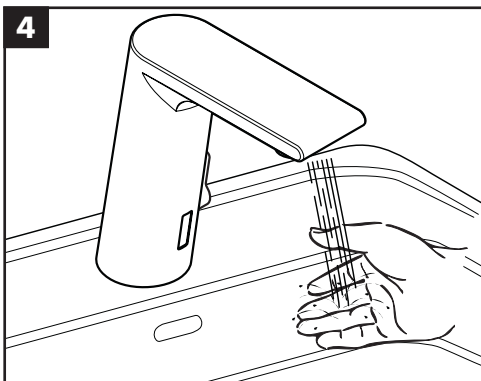
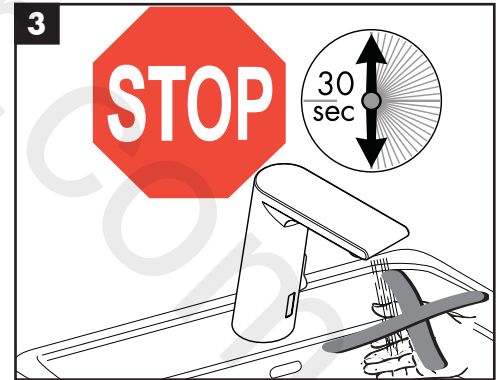
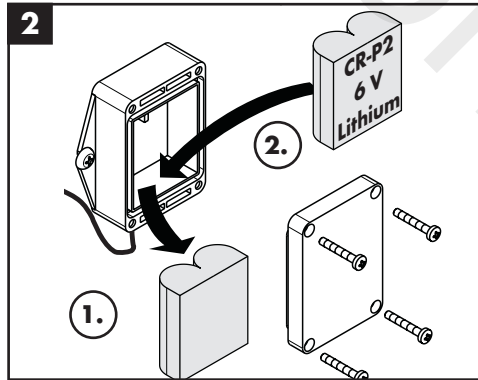
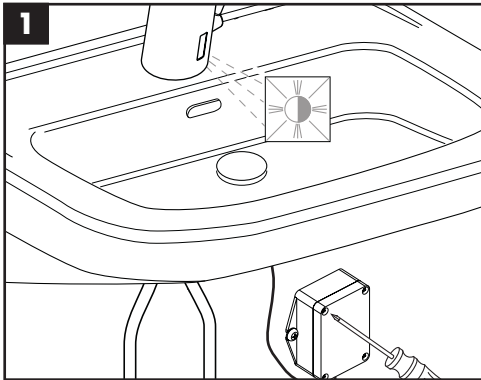
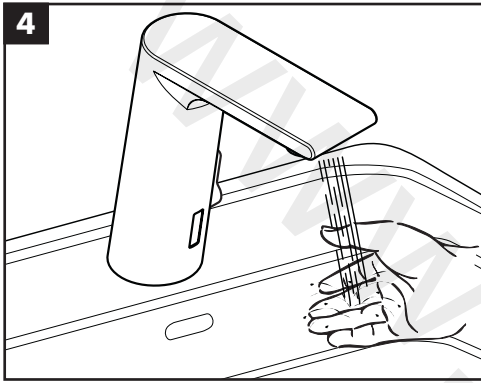
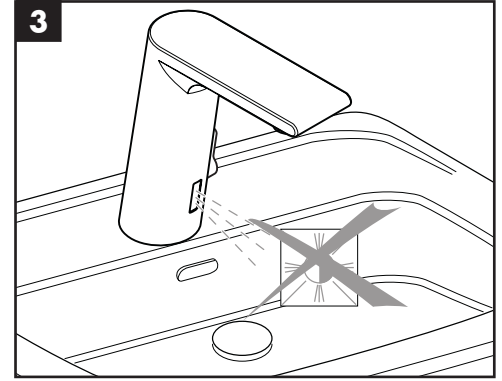
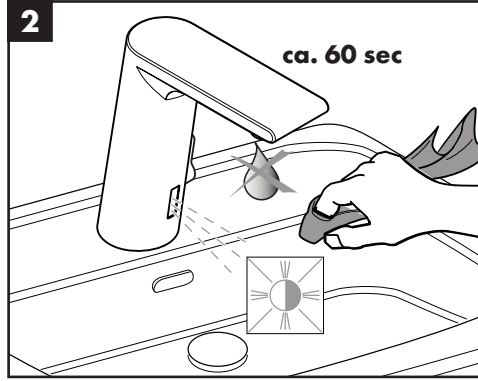
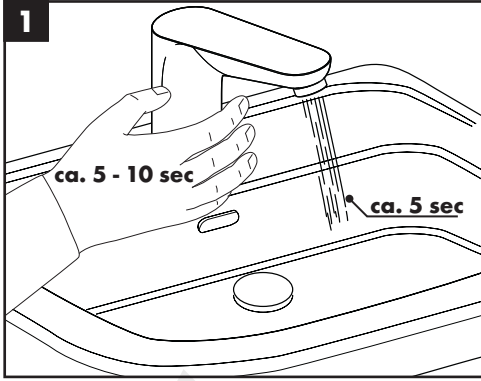

Metris
31100007

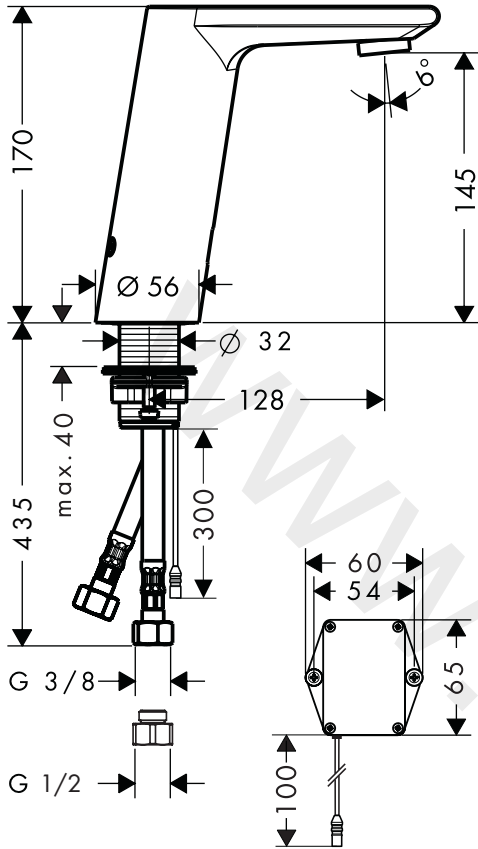

Metris
31100007

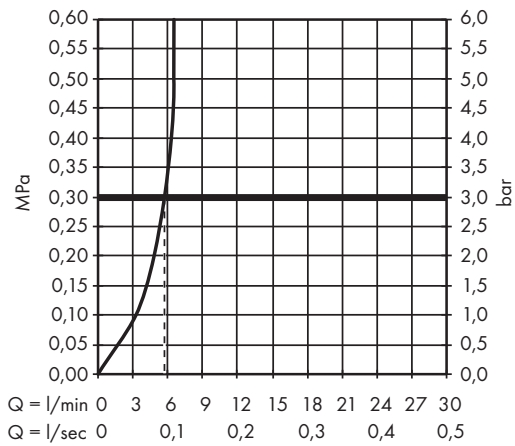



Metris
31100007

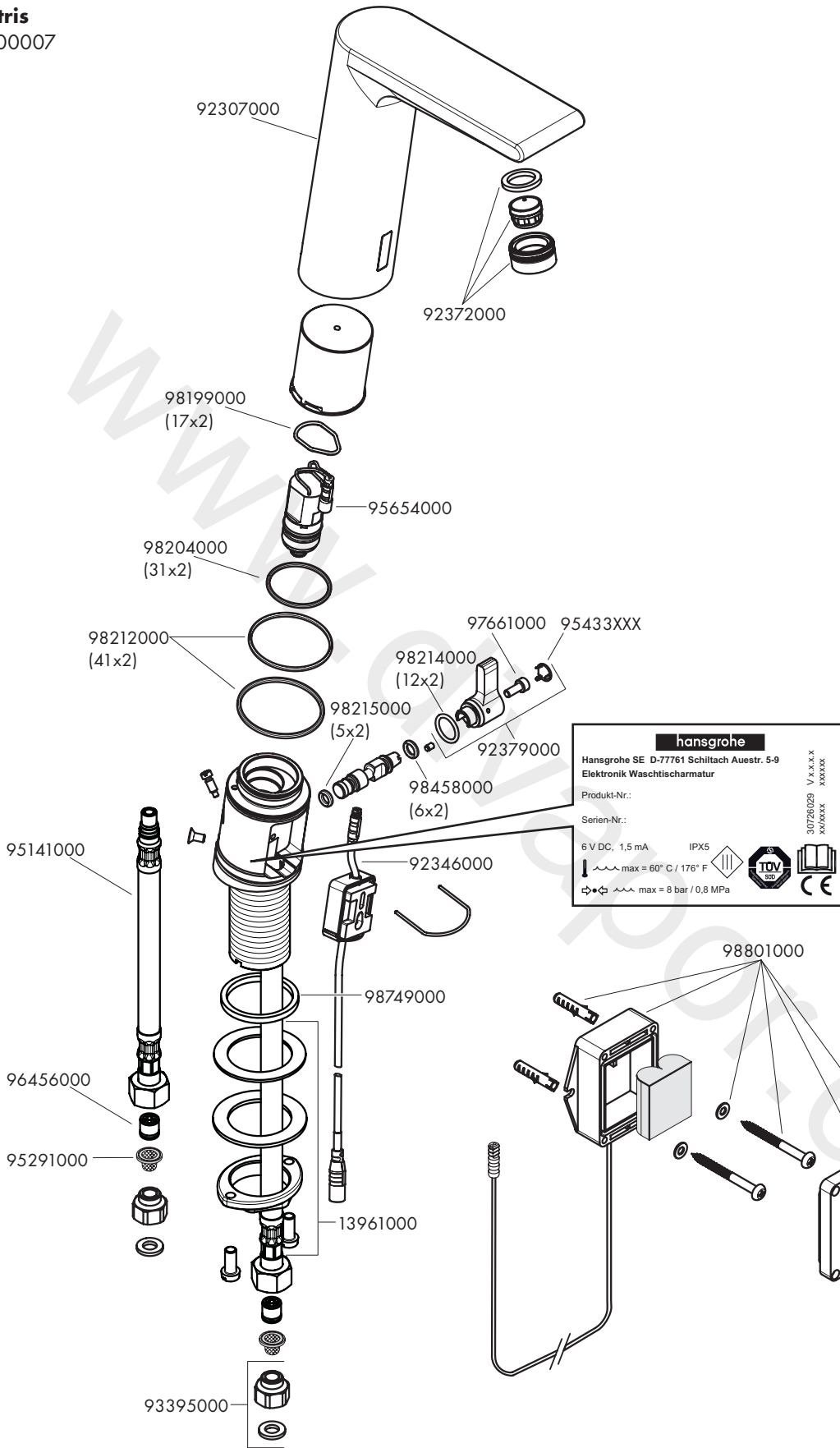

hansgrohe

Hansgrohe · Austraße 5 - 9 · D-77761 Schiltach · Telefon +49 (0) 78 36/51-1282 · Telefax +49 (0) 7836/511440
E-Mail: info@hansgrohe.com · Internet: www.hansgrohe.com