

32 049

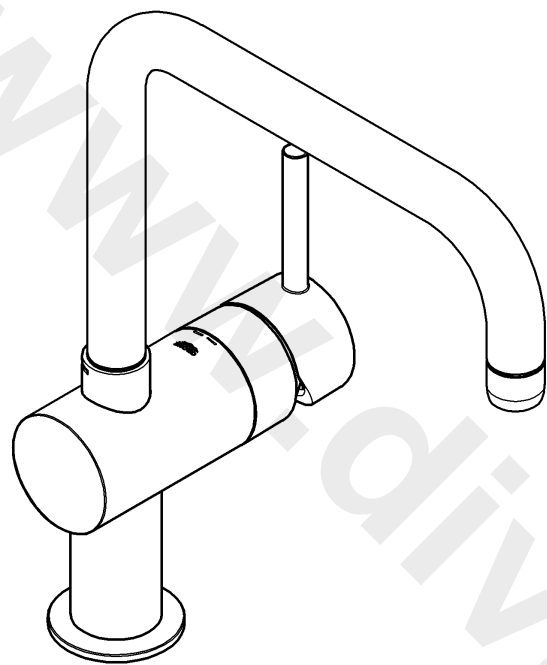

32 930

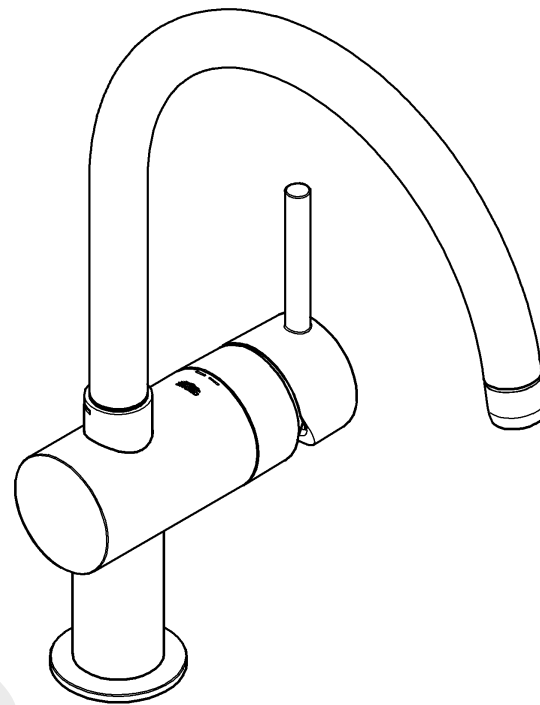

Minta

## Minta

**D** .....1

**AUS** .....1

**NZ** .....1

94.434.231/ÄM 209314/02.07

**GROHE**

ENJOY WATER®

32 049

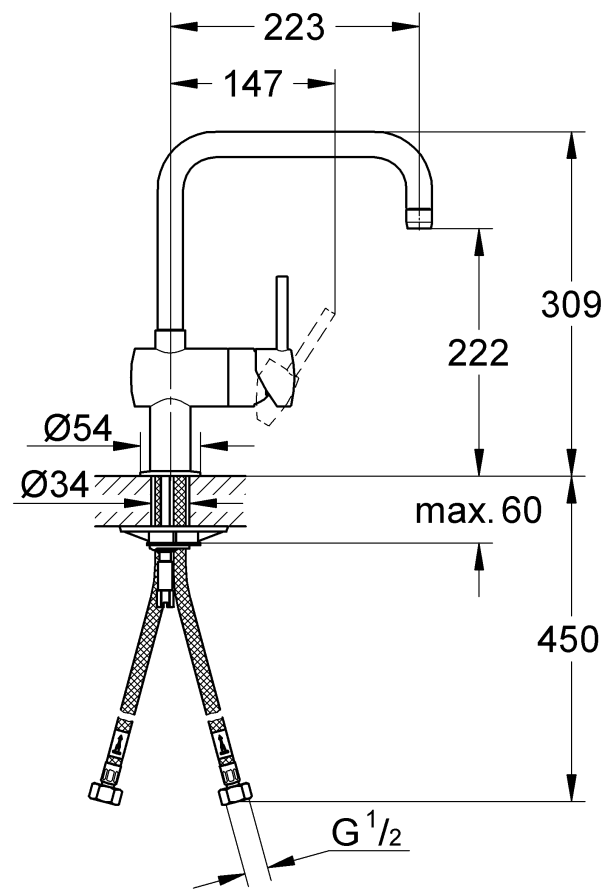

32 930

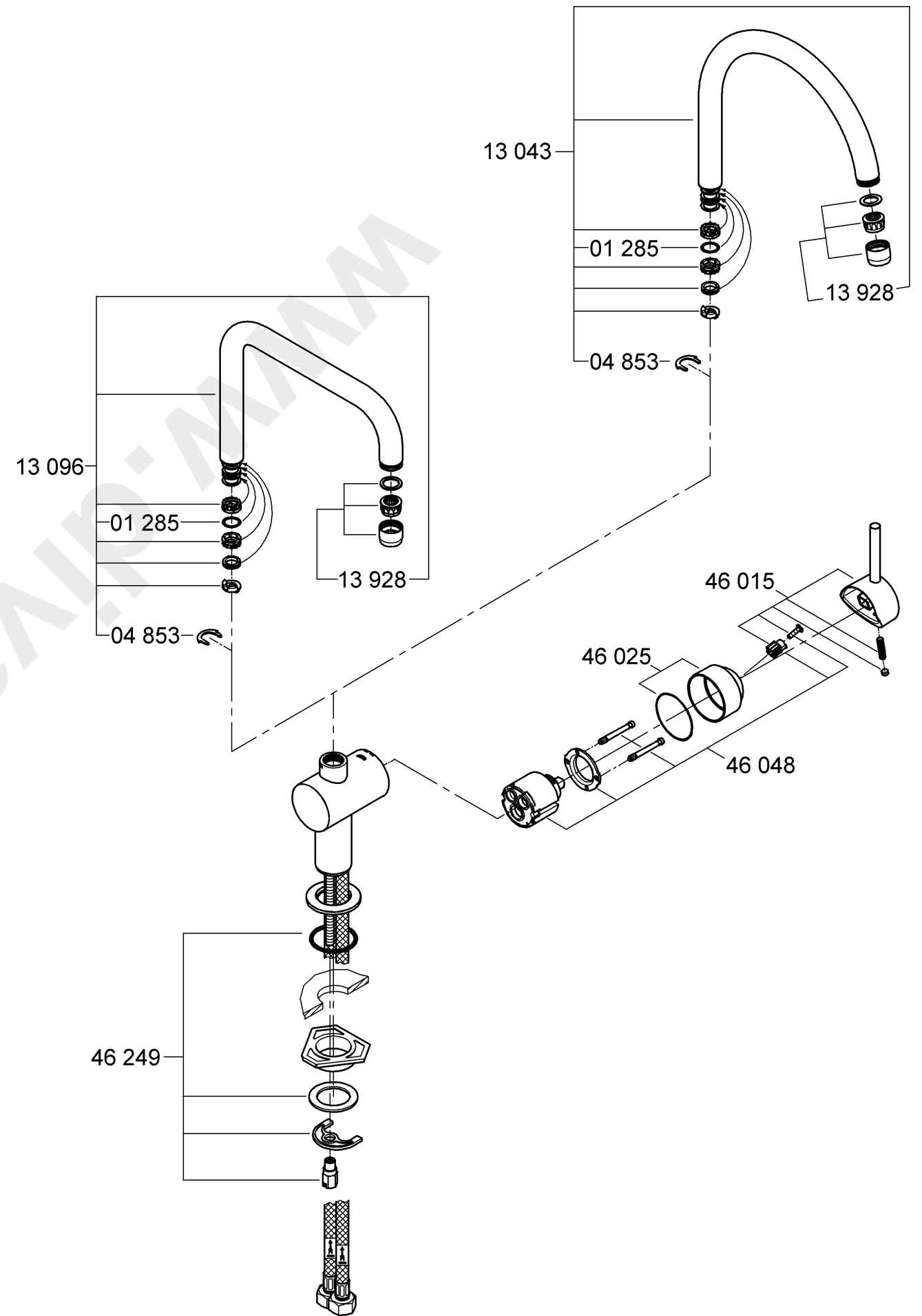
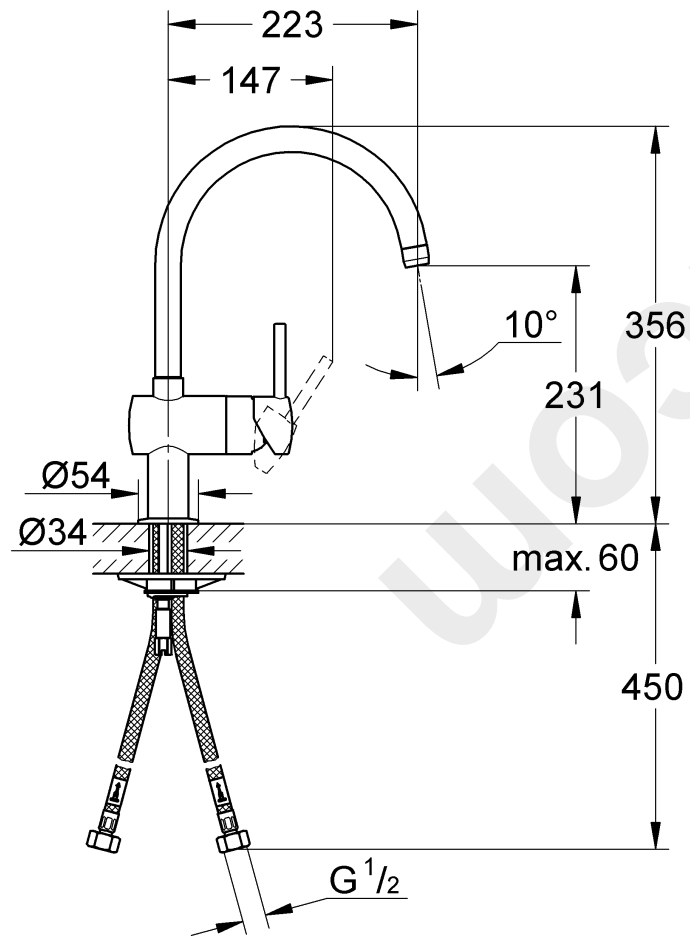

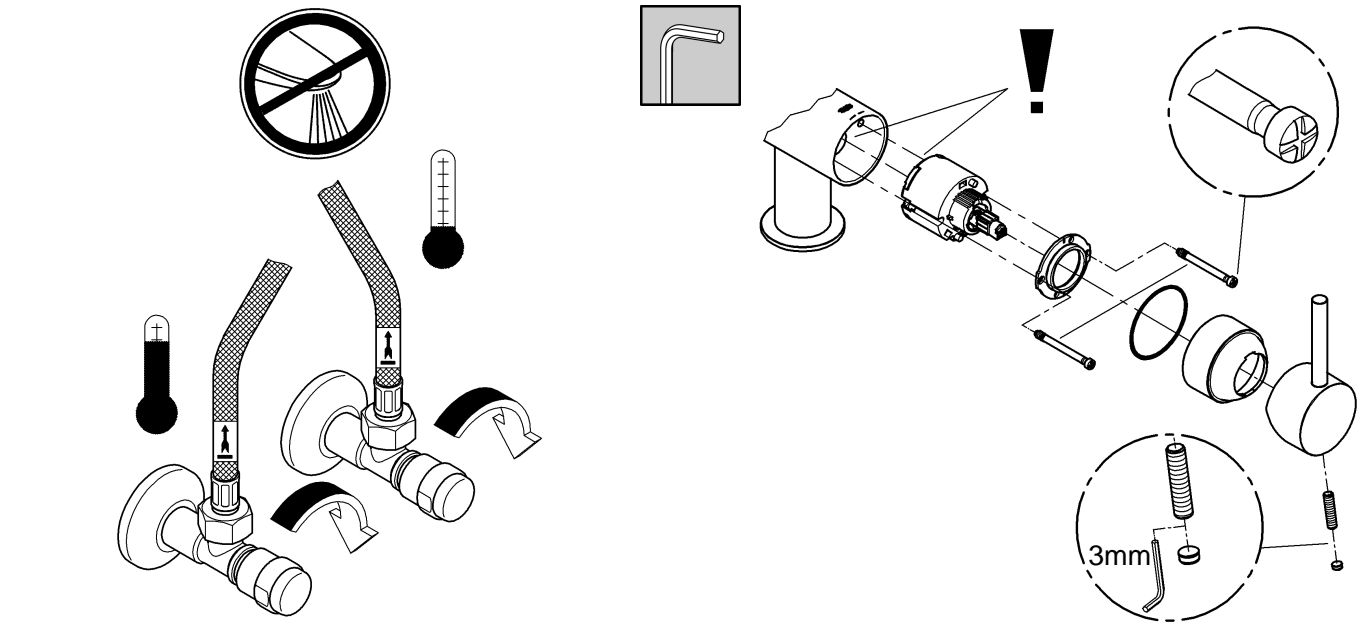
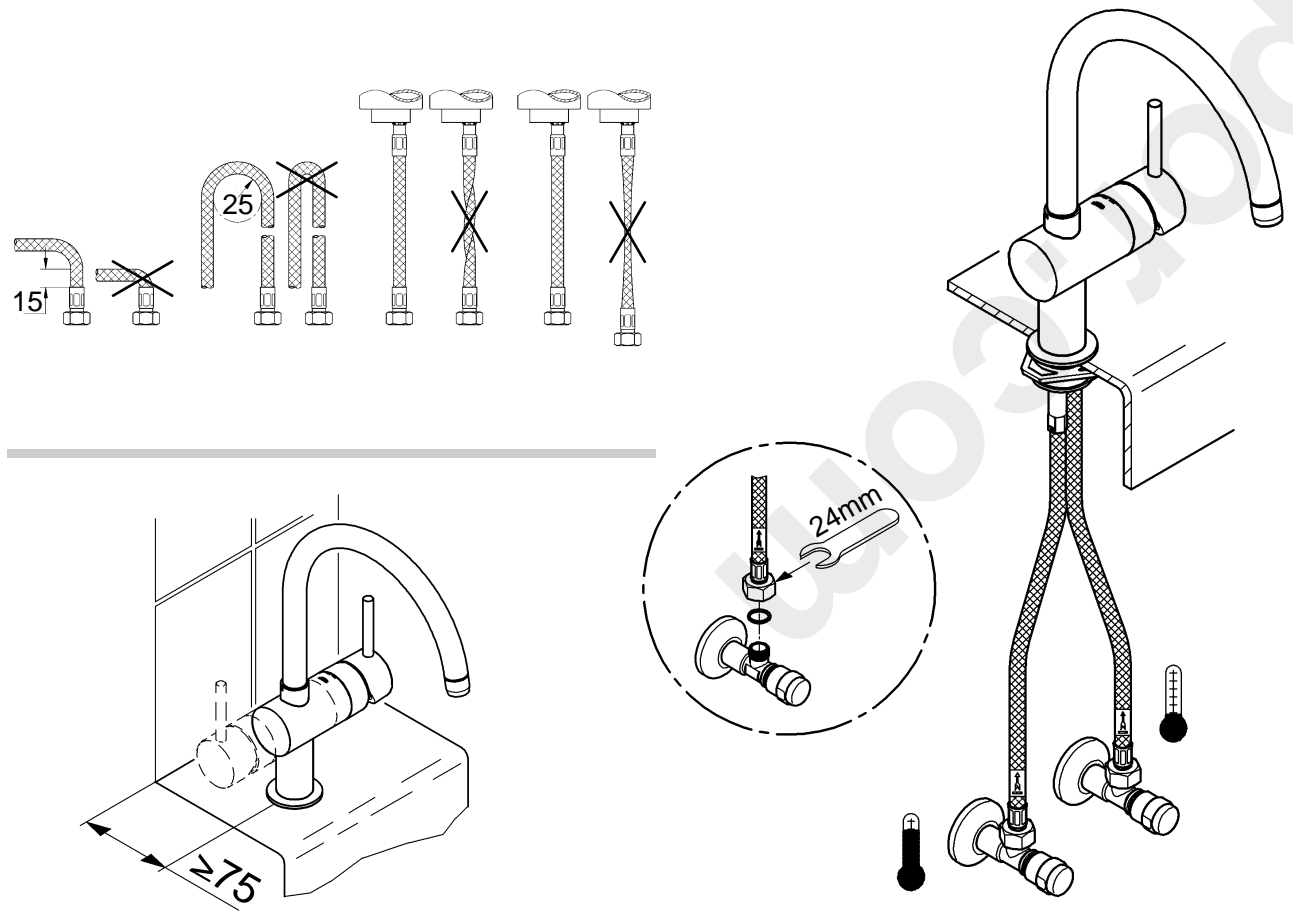
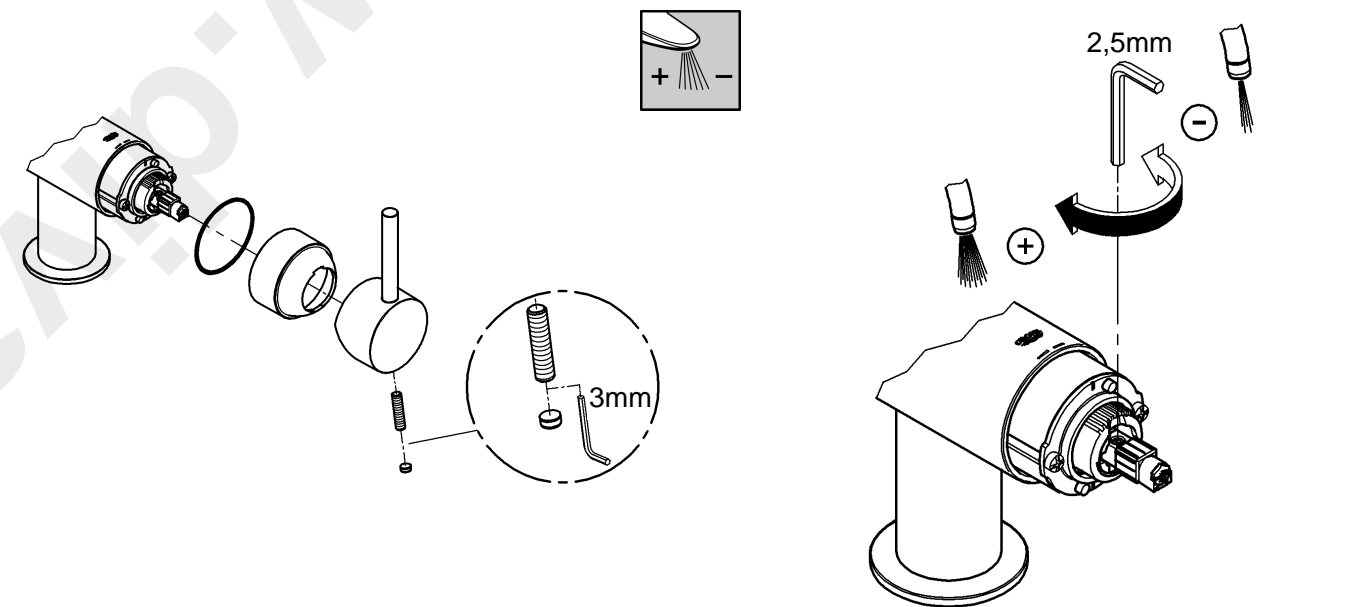
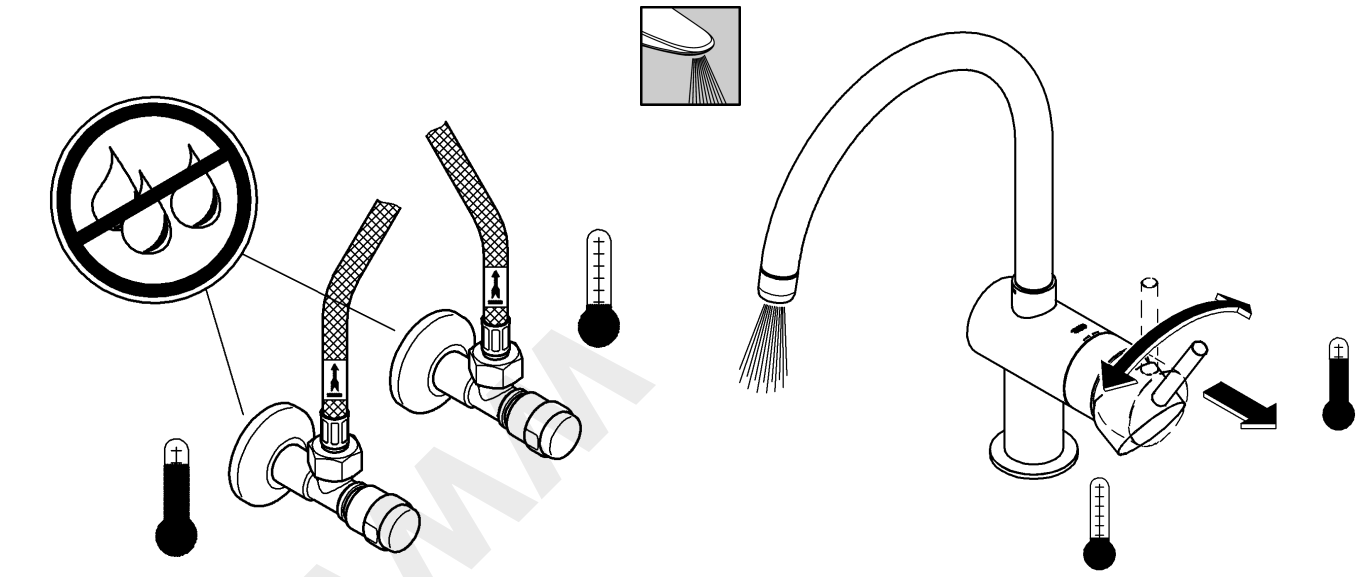
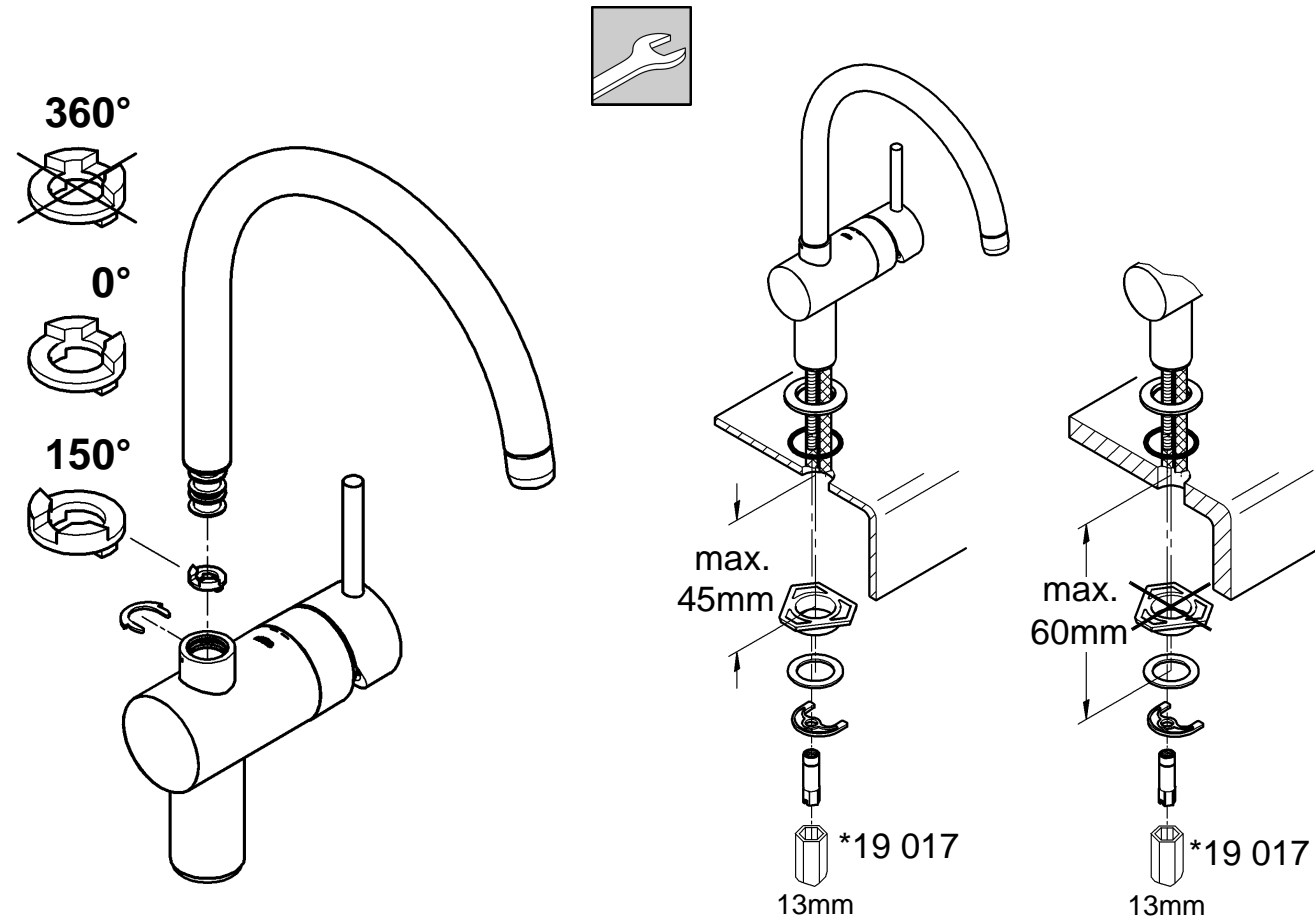



**Diese Technische Produktinformation ist ausschließlich für den Installateur oder eingewiesene Fachkräfte!  
Bitte an den Benutzer weitergeben!**

**Anwendungsbereich:**

Der Betrieb mit drucklosen Speichern (offenen Warmwasserbereitern) ist **nicht** möglich.

**Technische Daten**

Fließdruck:	min. 0,5 bar – empfohlen 1 – 5 bar
Betriebsdruck:	max. 10 bar
Prüfdruck:	16 bar
Durchfluss bei 3 bar Fließdruck:	ca. 8 l/min
Temperatur Warmwassereingang	max. 80 °C
Empfohlen (Energieeinsparung):	60 °C
Klemmlänge:	max. 60mm

Zur Einhaltung der Geräuschwerte nach DIN 4109 ist bei Ruhedrücken über 5 bar ein Druckminderer einzubauen. Höhere Druckdifferenzen zwischen Kalt- und Warmwasseranschluss sind zu vermeiden!



**Installation:**  
Rohrleitungen nach DIN 1988 spülen!



**Funktion:**  
Anschlüsse auf Dichtheit und Armatur auf Funktion prüfen.



**Mengenbegrenzung:**  
In Verbindung mit hydraulischen Durchlauferhitzern ist eine Durchflussmengenbegrenzung nicht zu empfehlen.



**Wartung:**  
**Alle Teile prüfen, reinigen, evtl. austauschen.**  
Bei Wartungsarbeiten Wasserzufuhr absperren!



**Beim Einbau der Kartusche auf richtigen Sitz der Dichtungen achten.**  
Schrauben wechselweise gleichmäßig anziehen.



**Ersatzteile:** siehe Explosionsdarstellung (\* = Sonderzubehör)

**Pflege:** siehe Pflegeanleitung



**This technical product information is exclusively for the installer or trained specialists.  
Please pass these instructions on to the user.**

**Application:**

Operation with unpressurised storage heaters is **not** possible.

**Specifications**

Flow pressure:	min. 0.5 bar - recommended 1 - 5 bar
Operating pressure:	max. 10 bar
Test pressure:	16 bar
Flow rate at 3 bar flow pressure:	approx. 8 l/min
Hot water inlet temperature	max. 80 °C
Recommended (energy saving):	60 °C
Clamping length:	max. 60mm

If static pressure exceeds 5 bar, a pressure reducing valve must be fitted.  
Avoid major pressure differences between hot and cold water supply.



**Installation:**  
Flush pipes thoroughly.



**Function:**  
Check connections for leaks and check function of fitting.



**Flow rate limitation:**  
The use of flow rate limiters in combination with hydraulic instantaneous heaters is not recommended.



**Maintenance:**  
**Inspect and clean all components and replace if necessary.**  
Shut off water supply for maintenance work.



**When installing the cartridge, ensure that the seals are correctly seated.**  
Tighten the screws evenly and alternately.



**Replacement parts:** see exploded drawing (\* = special accessory)

**Care:** see Care Instructions



A series of horizontal lines for writing, with a large, light gray watermark [www.divapor.com](http://www.divapor.com) overlaid diagonally across the page.

**Australia**

(National, Queensland)

**Argent Australia Pty. Ltd.**

ACN - 010 387 809  
18 Wandoo Street  
Fortitude Valley Queensland 4006  
Australia  
Tel. 1300 364 748  
Fax. 1300 656 057

**Australia**

(New South Wales)

**Argent Sydney**

280 Abercombe Street  
Chippendale New South Wales 2008  
Australia  
Tel. (02) 8394 5800  
Fax. (02) 8394 5888

**Australia**

(Victoria, South Australia, Tasmania)

**Argent Melbourne**

206-208 Coventry Street  
South Melbourne Victoria 3205  
Australia  
Tel. (03) 9682 1231  
Fax. (03) 9696 7661

**New Zealand**

**Correspondence:**

**Paterson Trading Co. Ltd.**

P.O. Box 511  
Auckland 1  
New Zealand

**Office:**

Corner Boston Road  
+ Severn Street  
Auckland 1  
New Zealand  
Tel. 09/373 4324  
Fax. 09/377 4739

**Singapore**

**Harpers Trading (S) Pte Ltd**

103 Kallang Avenue # 03 - 01/02  
AIS Industrial Building  
Singapore 339304  
Tel. 298 6800  
Fax. 298 4188

Grohe AG  
Postfach 13 61  
58653 Hemer  
Tel.: 0 23 72 / 93-0, Fax: 0 23 72 / 93 12 22

**GROHE**  
  
ENJOY WATER®