

Avensys

GB5

94.825.131/ÅM 206758/02.07

GROHE
ENJOY WATER®

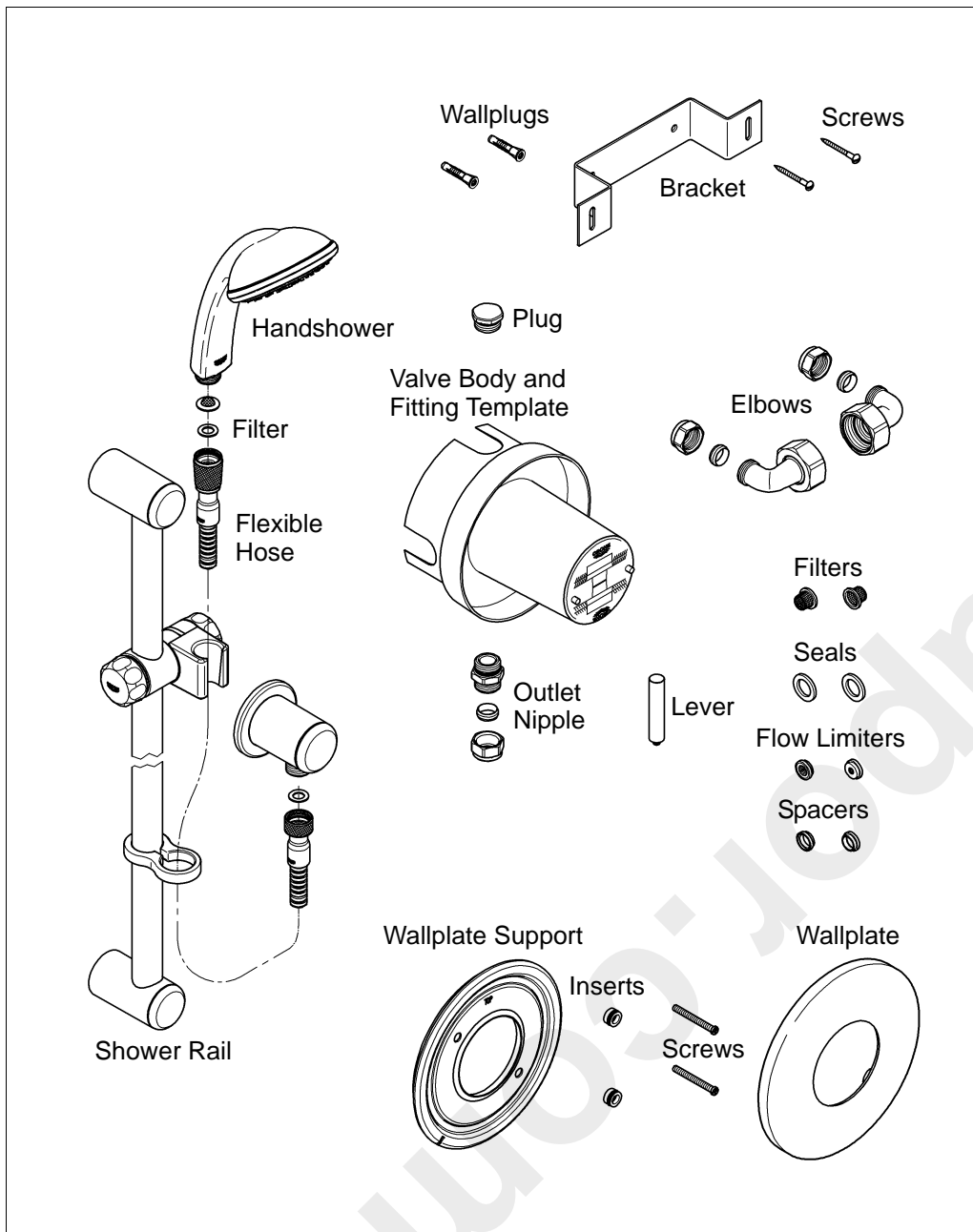

Please pass these instructions on to the end user of the fitting.

34 224

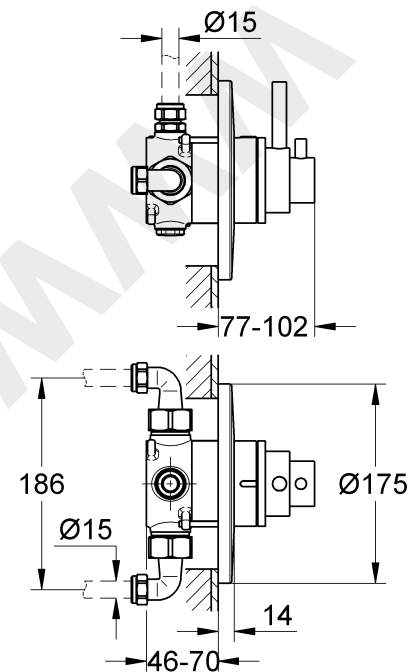

34 225

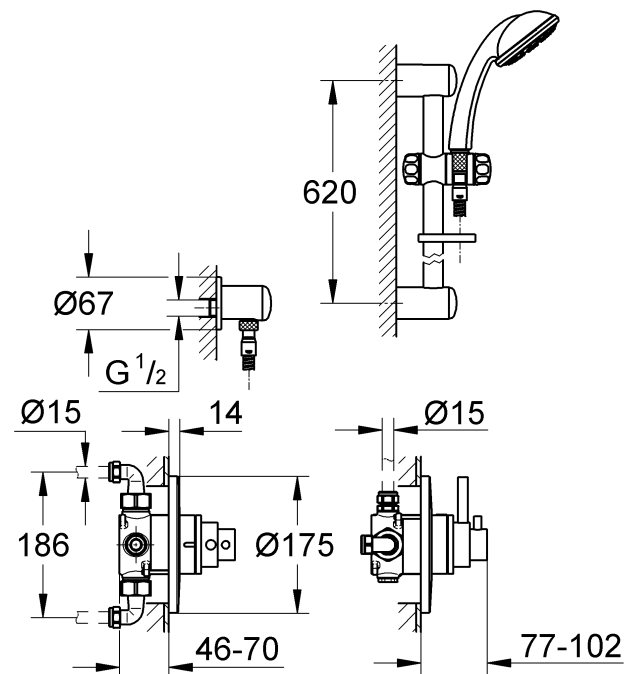

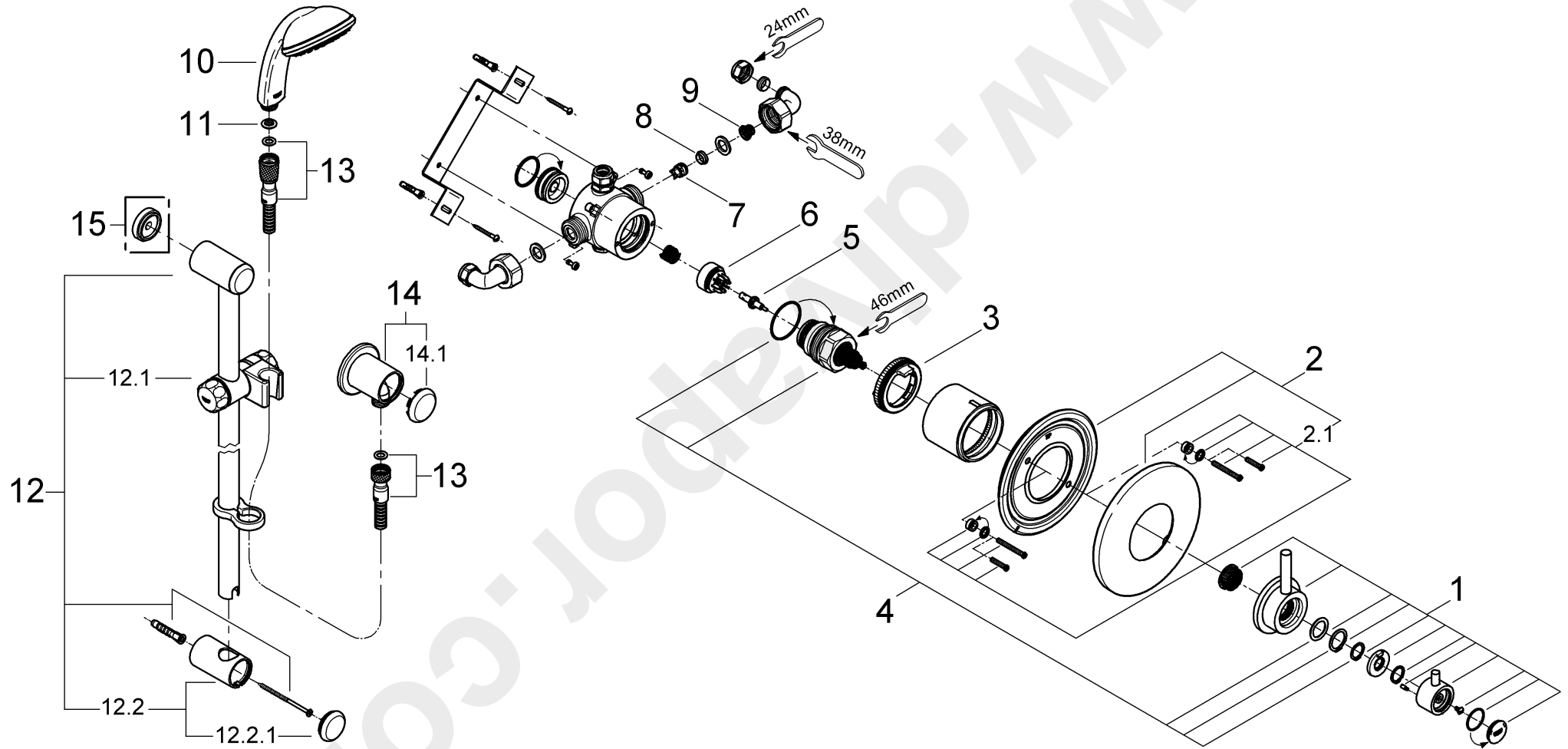

Index

Table Of Contents	1
Installation Dimensions	2
Spare Parts Drawing	3 + 4
Spare Parts List	5
Technical Data	6
Installation	7
Rough Installation	7
Preassemble Valve	8
Connect Valve	9
Wallplate Installation	10
Adjustment	11
Maintenance	12
Care	14
Trouble Shooting	14
Guarantee	15

Dear Customer,

thank you for choosing a GROHE product. Please follow these instructions carefully and you will enjoy many years of reliable service from this fitting.

Spare Parts

No.	Description	Cat.-No.	Pack- ing unit	No.	Description	Cat.-No.	Pack- ing unit
1	lever complete	47 766	1	12	Shower rail	28 666	1
2	Wall plate complete	47 768	1	12.1	Sliding shower holder	07 659	1
2.1	Screw set	09 361	2	12.2	Shower rail holder	45 362	1
3	Stop ring	47 593	1	12.2.1	Cover cap	45 363	1
4	Control unit	47 767	1	13	Flexible hose	28 161	1
5	Wax element	00 798	1	14	Elbow outlet	28 671	1
6	Slider	07 587	1	14.1	Cover cap	45 364	1
7	Non-return valve	06 544	2				
8	Flow limiter set	46 428	1		Optional accessory		
9	Filter	06 995	2	15	Compensation ring	45 406	1
10	Handshower	28 422	1				
11	Filter	07 002	2				

Technical Data

Functioning Principle

This **Avensys** mixing valve is a thermostatic mixer with wax cartridge. Turning the shut-off lever in a counter-clockwise direction opens the water flow. Turning the temperature lever in a counter-clockwise direction sets the temperature from cold to hot.

This product is supplied with connectors to fit \varnothing 15mm pipework. Connection should be hot left, cold right as viewed from the operating position.

Plumbing Systems

This thermostatic mixing valve is suitable for installation with:

- Gravity-fed plumbing systems with an open vented hot water cylinder
- Cold water storage cistern
- Mains pressure unvented and instantaneous thermal hot water storage systems
- Multi-point gas water heaters
- Combination boilers with a modulating hot water output
To maintain sufficient hot water output ensure the combination boiler temperature setting is on **high**.

Supply Pipework

Ensure the supply pipework is thoroughly flushed before installing the mixing valve. GROHE recommends installing isolating valves upstream of the mixing valve for servicing purposes.

New Water Regulations

This GROHE-product should be installed to comply with the New Water Regulations covering backflow prevention. It must also be installed in accordance with local bye-law requirements.

Specification

- Concealed thermostatic shower mixing valve
- Flow pressure
 - Low pressure 0.1 - 1 bar
 - High pressure 1 - 5 bar
- Avoid major pressure differences between hot and cold water supply:
For different supply pressures use enclosed flow limiters, see chapter "**Prassemble Valve**" on page 8.
- Max. operating pressure 5 bar
- Max. test pressure 16 bar
- Mixed water flow rate without downstream resistance:

Pressure	0.1	0.2	0.3	0.4	0.5	0.6	bar
Flow rate	7.5	10.5	14	17	18.5	21	l/min

- Temperature
 - Max. (hot water inlet) 80 °C
 - Recommended (for economy) 60 °C
 - Maximum temperature is reached when the temperature lever is rotated 270° in a counter-clockwise direction.
- Water connection
 - Cold water: marking **C** = right
 - Hot water: marking **H** = left

Installation

Rough Installation

The thermostatic shower mixing valve can be installed in two different ways. The mixing outlet can be at the bottom for use with a handshower or at the top for use with a headshower.

The concealed thermostatic shower mixing valve is supplied with a bracket.

- With bracket mounted from the front the valve can be used for installation into solid and dry-lined walls.
- With bracket mounted from behind the wall the valve can be used for installation into the front face of a stud partition wall structure or the rear face of a shower cubicle or laminated panel.

Solid and dry-lined walls

Determine the route for the incoming hot and cold water supply and for the outlet pipe-work in accordance with the thermostatic shower mixing valve.

1. Mark a 150mm diameter hole for the valve and mark the fixing hole positions for the bracket (A), see Fig. [1].

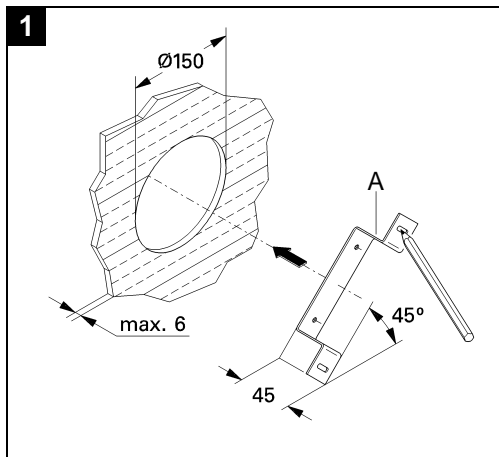

2. Drill 6mm diameter holes and insert the supplied wallplugs (A1), see Fig. [2].

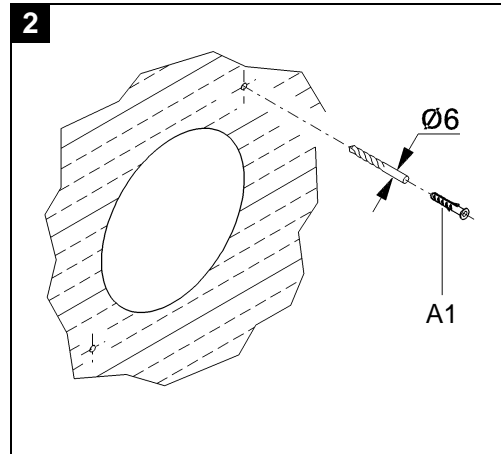

3. Remove the plaster and brick or block.

Laminated panel walls

Determine the route for the incoming hot and cold water supply and for the outlet pipe-work in accordance with the thermostatic shower mixing valve.

1. Mark a 150mm diameter hole for the valve and mark the fixing hole positions for the bracket (A), see Fig. [3].

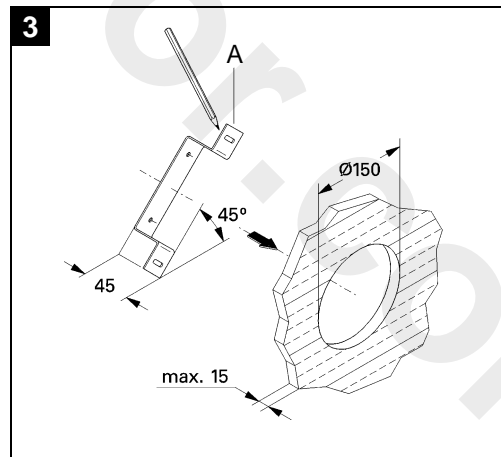

Installation

Preassemble Valve

1. Remove the two screws (B1) from the fitting template (B), then remove the template, see Fig. [4].

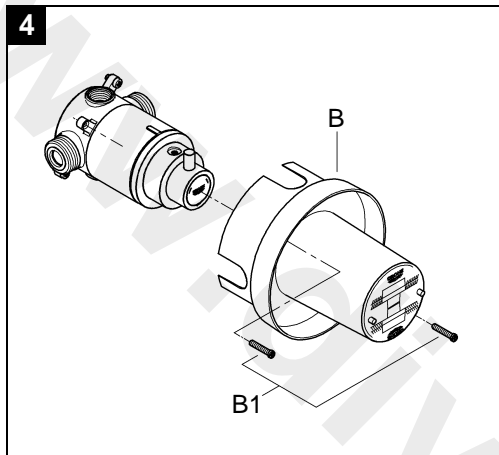

2. Close free outlet with plug (C), see Fig. [5].

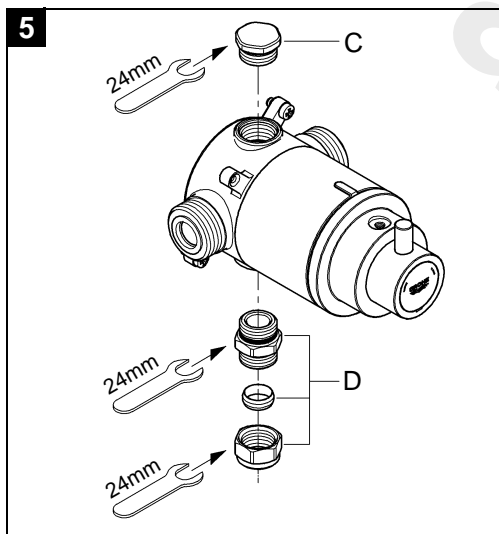

3. Thread the outlet nipple (D) with the O-ring seal into the valve body outlet.

4. Screw valve body (E) to bracket (A) with fixing screws (E1), see Fig. [6].

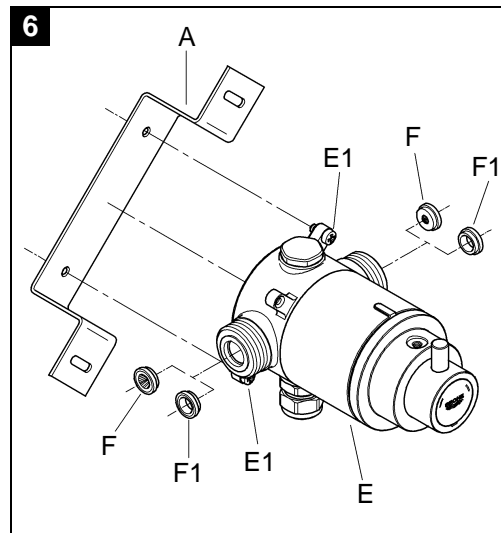

5. If there is a pressure differences between the hot and cold water supply install attached flow limiters (F) or spacers (F1) in the hot and cold water connection inlets, see table below.

Cold Water Inlet	Warm Water Inlet	Connection	
		Cold	Warm
0.1 - 1 bar	0.1 - 1 bar	spacer	spacer
1 - 5 bar	1 - 5 bar	7 l (green)	5 l (yellow)
1.5 - 10 bar	0.1 - 0.5 bar	7 l (green)	spacer
	> 0.5 bar	7 l (green)	5 l (yellow)

For **reversed supplies installation** the complete mixing valve must be rotated 180°.

Therefore shut-off lever, temperature lever, cover ring and stop ring must be dis-mounted, rotated 180° and reinstalled, see **Maintenance Control Unit** on page 12.

Installation

Connect Valve

1. Connect elbows (G) onto the supply pipes, see Fig. [7].

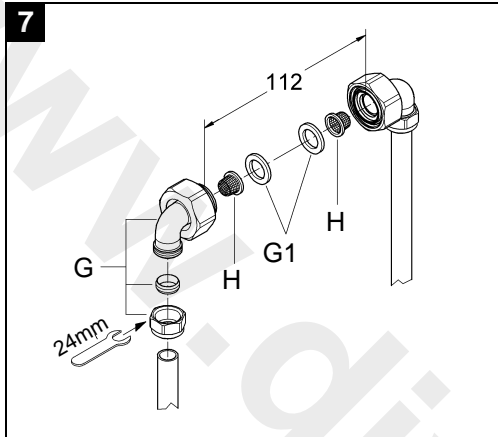

2. Install filters (H) and seals (G1) into the elbows (G).
3. Fix bracket (A) and valve (E) with screws (A1) between the elbows to the wall, see Fig. [8].

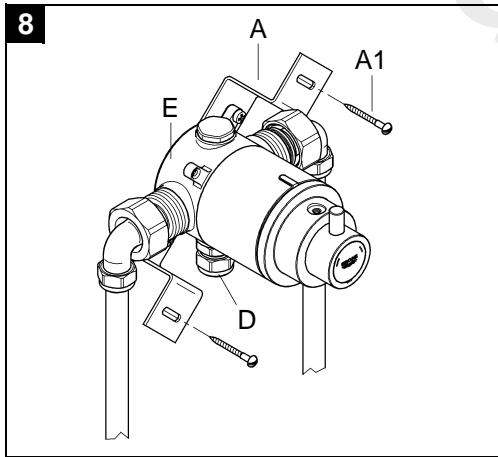

4. Connect mixed water supply to the outlet nipple (D).

The hot water supply must be connected on the left and the cold water supply on the right.

5. Connect elbows (G) to valve body (E) and tighten nuts (G2) [torque min. 20 Nm], see Fig. [9].

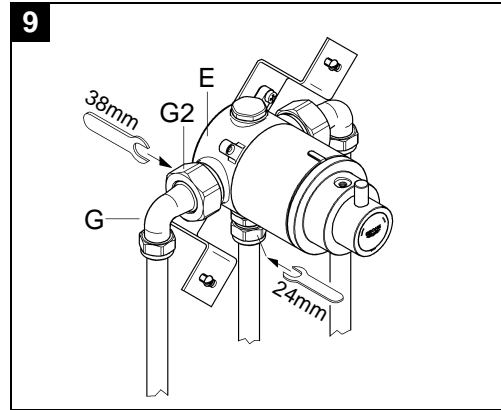

Open hot and cold water supply.

Check the pipework and connections to the thermostat mixing valve for leaks.

6. Reinstall fitting template for finishing wall surface as described in Fig. [4] in reversed direction.
7. Observe the installation depth in accordance with the instructions given on the fitting template, see Fig. [10].

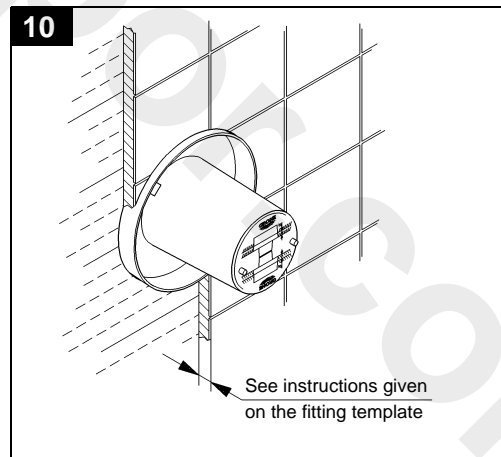

Plaster and tile the wall.

Do not remove fitting template before installation is completed.

Installation

Wallplate Installation

1. Remove the two screws (B1) from the fitting template (B), then remove the template, see Fig. [11].

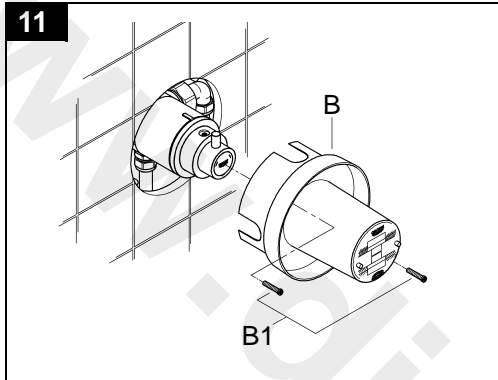

2. Place inserts (K) in the wallplate support (L), see Fig. [12].

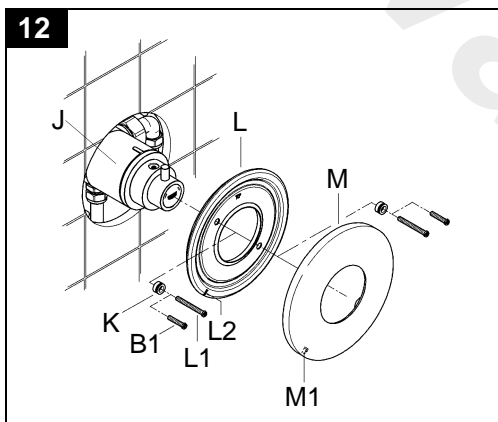

3. Slide the wallplate support (L) over the cover ring (J) in position **TOP**.

Additionally seal the top edge of the wallplate support with silicone if it is fitted against a particularly rough surface (deep tile joints, highly textured tile).

4. Tighten wallplate support (L) with two of the four screws [(B1) = template screws or (L1)] into the valve body. These screws allow for variation in wall thickness when mounting the wallplate.

Check correct position of the seal in the wallplate.

5. Snap wallplate (M) into the wallplate support (L).

To ensure that the wallplate is correctly seated, lug (M1) must engage in the recess (L2) on the wallplate support.

6. Screw in lever (X), see Fig. [13].

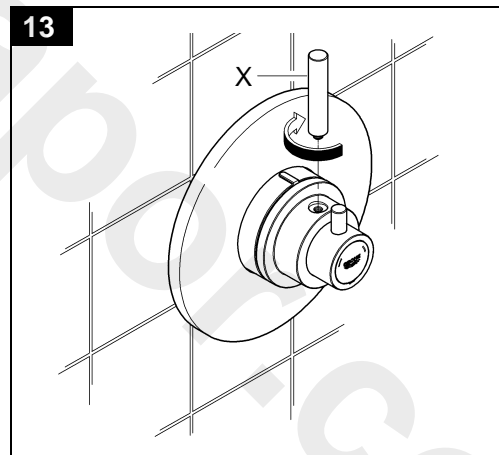

Installation

Adjustment

The temperature of the outflowing water is factory set to 43 °C. A temperature adjustment is necessary if:

- The maximum water temperature measured at the outlet varies from the factory set temperature.
- After any maintenance operation on the thermostatic cartridge.

For temperature adjustment please proceed as follows:

1. Turn the shut-off lever counter-clockwise to fully open position and open water flow.
2. Turn the temperature lever counter-clockwise to maximum hot water temperature.
3. Lever out cap (T), see Fig. [11].

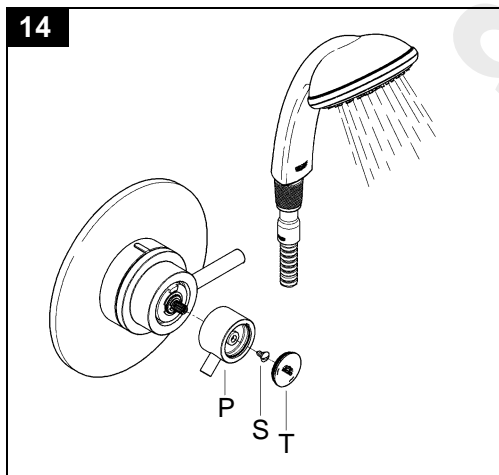

4. Unscrew screw (S).
5. Pull off temperature lever (P).

6. Check the temperature of the outflowing water with a thermometer, see Fig. [15].

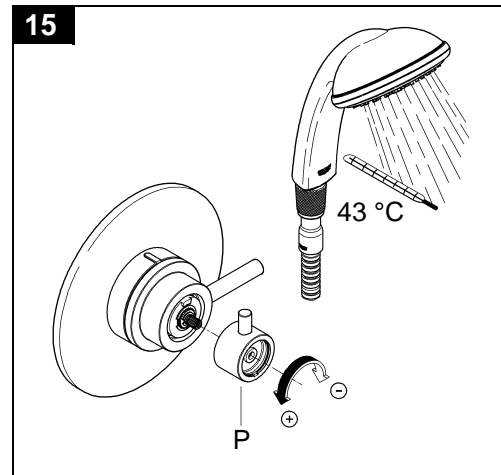

7. Push on temperature lever and adjust temperature to 43 °C.
Turn clockwise (to reduce temperature) or counter-clockwise (to increase temperature).
8. Pull off temperature lever (P) and reinstall in hot water position as described in Fig. [14] in reversed direction.

The thermostat mixing valve is now ready for use.

Maintenance

I. Control Unit

1. Shut off hot and cold water supply!
2. Turn the shut-off lever counter-clockwise to fully open position.
3. Turn the temperature lever counter-clockwise to maximum hot water temperature.
4. Lever out cap (T), see Fig. [16].

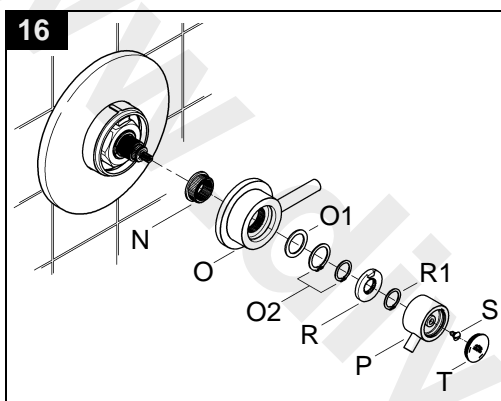

5. Unscrew screw (S).
6. Pull off temperature lever (P).
7. Remove circlip (R1) and pull off scale ring (R).
8. Remove circlips (O2), washer (O1) and pull off shut-off lever (O).
9. Pull off adapter (N).
10. Pull off wallplate (M), see Fig. [17].

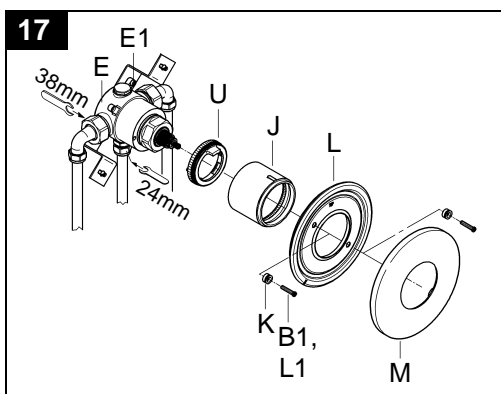

11. Unscrew screws (B1 or L1) and take out inserts (K).

12. Remove wallplate support (L).
13. Unscrew connections, fixing screws (E1) and take valve (E) from the supplies.
14. Pull off cover ring (J) and stop ring (U).
15. Screw out control unit (V), see Fig. [18].

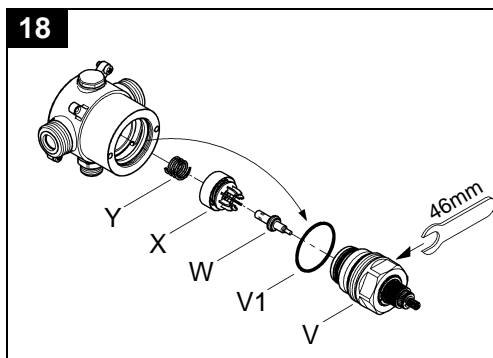

16. Take out O-ring seal (V1).
17. Take out wax element (W), slider (X) and spring (Y).

Inspect and clean all parts, replace if necessary and grease with special valve grease.

Reinstall control unit

1. Unscrew seat (Z) with O-ring, see Fig. [19].

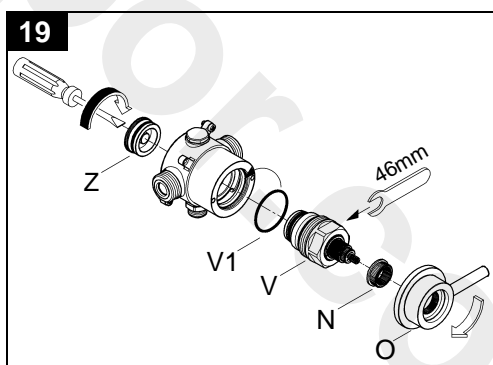

2. Reinstall O-ring seal (V1).
3. Screw in control unit (V).
4. Push on adapter (N) and shut-off lever (O).
5. **Turn the lever clockwise to the close position.**
6. Pull off shut-off lever (O) and adapter (N).

Maintenance

7. Reinstall wax element (W), slider (X) and spring (Y) from behind, see Fig. [20]

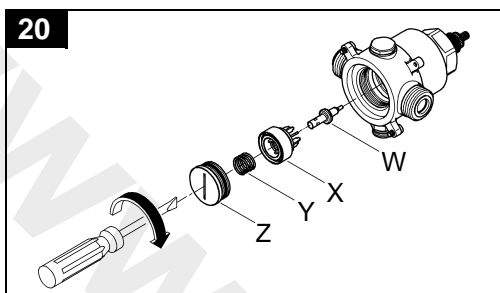

8. Tighten seat (Z) in the valve body.
9. Unscrew seat 1/8 to 1/6 turn (45° to 60°), see Fig. [21].

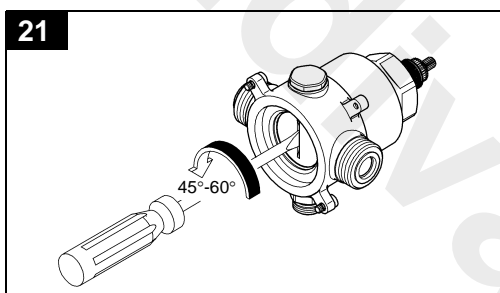

10. Connect elbows (G) to valve body (E) and tighten compression nuts, see Fig. [22].

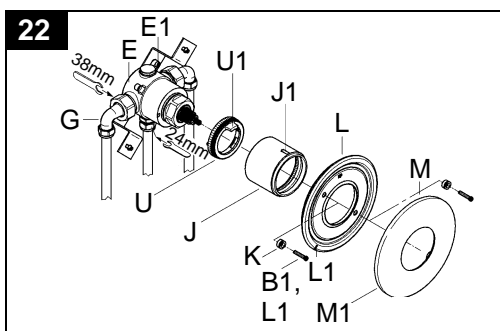

11. Connect mixed water supply.
12. Tighten fixing screws (E1).
13. Push on stop ring (U) with catch (U1) on top.
14. Reinstall cover ring (J) with mark (J1) on top.

15. Place inserts (K) in the wallplate support (L).
16. Slide the wallplate support (L) over the cover ring (J) in position **TOP**.
17. Tighten wallplate support (L) with screws (B1 or L1) into the valve body.
18. Snap wallplate (M) into the wallplate support (L).
19. Push on adapter (N), see Fig. [23].

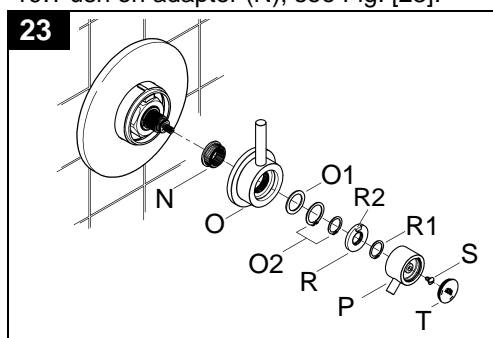

20. Push on shut-off lever (O) in closed position.
21. Reinstall washer (O1) and fix with circlips (O2), the smaller one is cloth to the shut-off lever.
22. Push on scale ring (R) with the stop (R2) on top and fix with clip (R1).
23. Reinstall the temperature lever (P) in position hot water.
24. Fix temperature lever with screw (S) and cover with cap (T).

Readjustment is necessary after every maintenance operation on the control unit, see chapter “**Adjustment**” on page 11.

II. Non-return valve, see spare parts drawing on page 3, 4, and Figs. [16], [17].

1. Same procedure as for control unit, see Figs. [16] and [17], points 1 to 13.
2. Unscrew elbows, see spare parts drawing on page 3 and 4.
3. Remove flow limiter (10) if installed.
4. Take out and replace non-return valve (9). Reassemble in reverse order.
Only genuine GROHE replacement parts must be used.

Care

We want to ensure that you get long-lasting satisfaction and pleasure from your GROHE fitting. Therefore, please read the following care instructions because damage to the surface and underlying material resulting from improper treatment is not covered by our guarantee.

Do not use any abrasive sponges or scouring agents for cleaning. We also advise not to use cleaning agents containing solvent or acid, limescale removers, household vinegar and cleaning agents with acetic acid. They are aggressive to the surface and will leave

your fitting dull and scratched. As the formulations of commercially available cleaning agents frequently change, we cannot guarantee they will provide the gentle care our fitting deserves.

Clean the fitting with a little soap and a moist cloth only, then simply rinse off and wipe dry. You can avoid lime spots by drying the fitting each time it is used. If lime deposits do occur, remove them with **Grohclean** (ref. no. 45 939), our environment-friendly cleaning liquid. **Grohclean** is specially formulated to gently clean the surface of our fittings.

Trouble Shooting

Problem	Cause	Remedy
Thermostatic valve opens through hot	Hot and cold water supplies have been connected in reverse	Rotate the thermostatic mixing valve
Range of temperature adjustment restricted	High pressure difference between hot and cold water supply	Install flow limiter see chapter Exposed Installation
Shower insufficiently cold or hot	Adjustment incorrectly set Hot water supply temperature too low	Refer to the instructions in chapter Adjustment Check hot water source temperature setting
No flow of hot or cold water	Either the hot or cold side is not fully pressurized Debris caught inside the inlet of the control unit	Replace non-return valve, refer to chapter Maintenance Remove mixing valve and flush out or remove any debris lodged inside the hot or cold inlets or filters
Hot water emerges to cold water supply or vice versa	Non return valves are damaged in cause of lime	Replace non-return valve, refer to chapter Maintenance

Guarantee

Guarantee declaration

Our products correspond to the valid technical and water supply standards as well as the relevant approvals requirements. We guarantee them to be free of design and production faults at the time of delivery and that with correct use and care in accordance with our printed instructions they will function reliably.

Guarantee period

- The guarantee is valid in private homes for 5 years from the purchase date. Proof of purchase has to be provided when making a guarantee claim.
- By use in commercial or institutional applications the guarantee is valid for 1 year after first use. An extension of the guarantee up to 5 years can be achieved by showing that the product is professionally maintained each year.

To make a guarantee claim, proof of purchase or, the beginning of use is required. The guarantee period is not renewed or increased through supply of spare parts or repair during the guarantee period. The guarantee period for purchased spare parts is the same as for original products.

Guarantee performance

- A) During the whole guarantee period we will correct all functional defects for which we are responsible (limitations see E + F).
- B) It is our option if we correct the defects by repair or replacement.
- C) During the above guarantee period we will not charge for the cost of parts, travel, working time, freight and packaging needed to effect the correction of defects.
- D) If we are not able to correct the defect we are prepared to supply a replacement product.
- E) Deliberate or careless damage is not covered by this guarantee. If the installation, assembly or care instructions that were valid at the time of installation are not followed or the product is used for a purpose other than that given in the written information the guarantee declaration does not apply. Problems caused by dirt, lime-scale or aggressive cleaners are not covered by the guarantee.
- F) The guarantee becomes void if repairs are not carried out competently or spare parts of non GROHE origin are used.
- G) Replaced parts become the property of GROHE and are to be surrendered to our service personnel or sent to our registered offices.

Please enter date of purchase and installation here.

Our address

GROHE Limited
1, River Road
Barking,
Essex, IG11 OHD
GB
Tel.: 0208 / 594 72 92
Fax: 0208 / 594 88 98



Grohe Water Technology AG & Co. KG · P.O. Box 13 61 · D-58653 Hemer/Germany
Tel. +49 (0) 23 72 / 93 - 0 · Fax: +49 (0) 23 72 / 93 13 22