

410156 - Trade Mono mixer

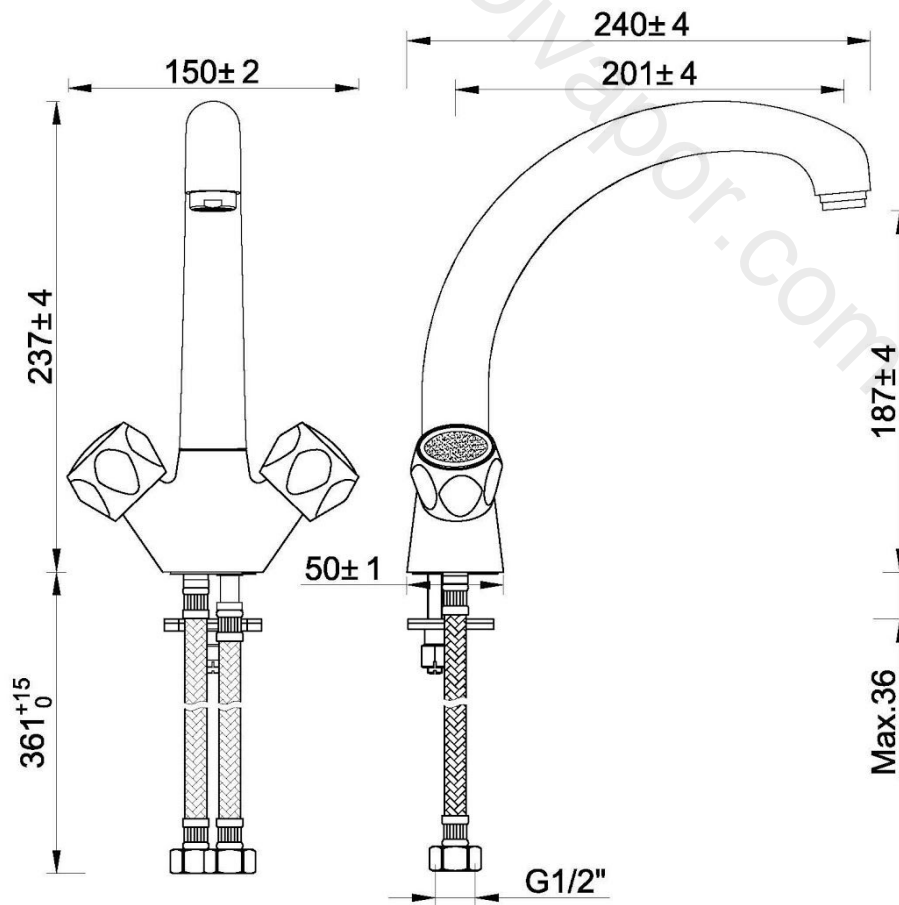

Useful Information	
Minimum operating pressure	0.2 bar
Maximum operating pressure	5 bar
Guarantee Length	2 years

Technical Diagram



Exploded Diagram

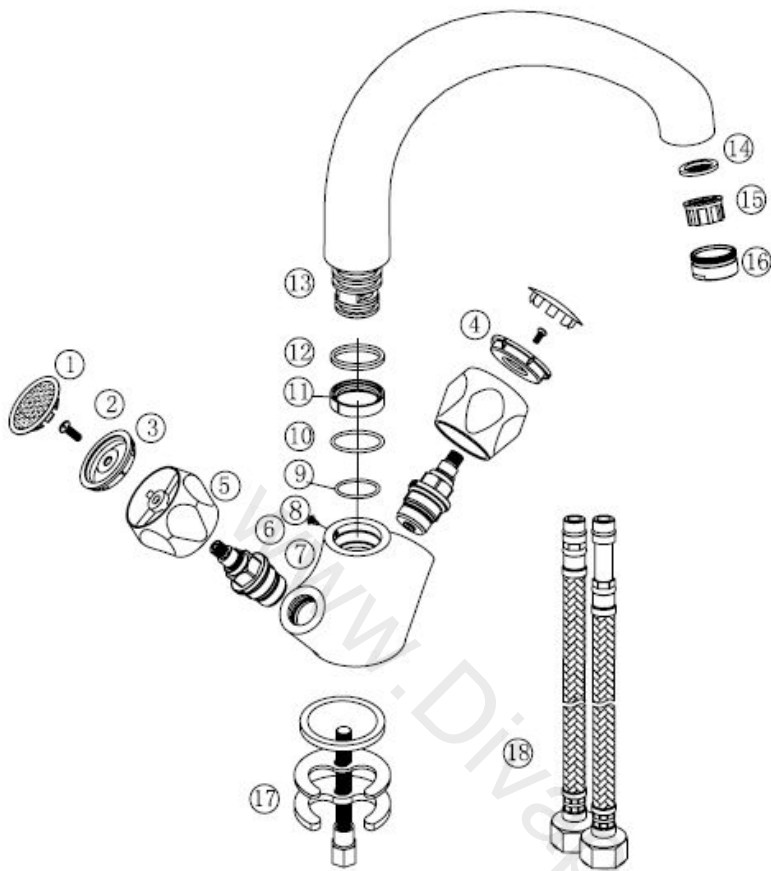

Item Number	Supplier Ref	Item Description	Quantity	Material	Spares Available
1	P01-A	Indice	2	ABS	Yes
2	SC4-10S	Screw	2	Stainless Steel	Yes
3	P01-C H	Indice Seat	1	ABS	Yes
4	P01-C C	Indice Seat	1	ABS	Yes
5	H01-C	Handle	2	ZINC	Yes
6	VS5412-BZ20	Valve	2	BRASS+EPDM	Yes
7	M0113Z-01	Tap Body	1	BRASS	No
8	SC4-7.5S	Screw	1	Stainless Steel	Yes
9	OR014	O ring	1	EPDM	Yes
10	OR015	O Ring	1	EPDM	Yes
11	M33247-N1	Block Ring	1	POM	Yes
12	M0112-02-01	Washer	1	POM	Yes
13	167020-02	Spout	1	BRASS	No
14	A13-04X	Washer	1	EPDM+Stainless Steel	Yes
15	A13-02	Flow straightener	1	POM	Yes
16	A14-04	Flow straightener Shell	1	ABS	Yes
17	N24-F	Fixing kit	1	Steel+NBR+Brass	Yes

18	BZG12-1/2"-370	Braided Connectors	1	Stainless Steel+BRASS+ EPDM	Yes
----	----------------	-----------------------	---	-----------------------------------	-----

Flow Rates

www.Divapor.com

FAQ

What should I do if my tap is dripping/leaking?

Cleaning the valve (if water dripping from tap)

Before carrying out any maintenance, turn off the mains water supply. If unsure contact a qualified tradesman.

1. Remove the cap (e), grub screw (a), handles (b).
2. Remove the valve (d) using a suitable spanner, clean thoroughly under cold water
3. to remove any build up of limescale or debris.
4. If necessary replace the valve.
5. Replace the valve (d) into the body, tighten the valve using a suitable spanner.
6. Replace the handles (b) and indice (f), tighten the grub screw (a).
7. Re-fit the cap (e) to handle.

What does the Guarantee Cover?

The Guarantee Covering leakage, manufacturing defects and Chrome plating

The guarantee does not cover:

- Damage or defects caused by:
 - general wear and tear (including special non-chrome finishes; components such as filters, seals, 'O'rings and washers)
 - incorrect installation
 - repair using non- PPI parts
 - accidental or wilful misuse
 - corrosion and the use of inappropriate cleaning products.
 - system debris including the build up of limescale (which can be controlled through regular servicing and maintenance).
- Compensation for loss of use of the product or consequential loss of any kind.