

# Intelligent Care

## MX1 Basin Mounted Tap

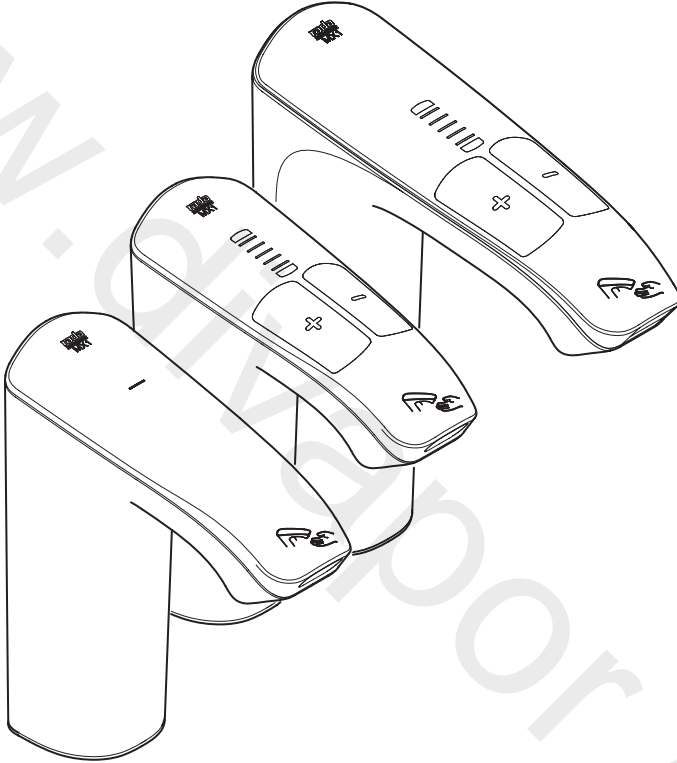

### Installation Guide

*Please leave these instructions with the user*

**rada**

## General

Make sure that the Rada MX1 is installed by a competent installer.

The product commissioning, clock (date/time) and tap set up can only be done in conjunction with the “**RADA AP1**” available from the Apple APP store. Time and date setting is critical to ensure data reporting is correct.

**Note:** Clock settings are lost after a period of 24hrs without mains power. When power is restored clock settings return to factory default (1st February 2016) and will need to be reset via the APP. Minimum charge time required for settings to be successfully set is 1 hour.

Shut off the main water and electrical supply.

Observe all local plumbing and building codes.

The Rada MX1 is a type 1, electronic, electrically operated, independently mounted valve. It is intended for surface mounting and is for connection to the mains water supply.

Inlet Unit. Comprising of Filter / Flow Regulator / Check valve / Isolation is an integral component of the tap, failing to install will invalidate the product's warranty.

The Rada MX1 must only be supplied from the power adaptor provided.

The power adaptor must be connected to the fixed wiring of the electrical supply via a switched 3A fused spur.

If the power adaptor supply cord is damaged the power adapter must be replaced by a competent person.

The Rada MX1 has been certified for use in UK Healthcare premises as a TMV3 approved valve, the approved designations of use are HP-WE.

For Healthcare installations refer to the TMV3 Requirements Manual which is available to view or download from our website [www.radacontrols.com](http://www.radacontrols.com).

Where chlorine disinfection is practised, **DO NOT** exceed a chlorine concentration of 50 mg/l (ppm) in water, per one hour dwell time. Such procedures must be conducted strictly in accordance with the information supplied with the disinfectant and with all relevant Guidelines/Approved Codes of Practice.

## Important Safety Information

The use of the word 'failsafe' to describe the function of any thermostatic mixing valve is both incorrect and misleading. In keeping with every other mechanism it cannot be considered as being functionally infallible.

Malfunction of thermostatic mixing valves can be detected by the use of proper temperature checking and maintenance routines.

Certain types of system can result in the thermostatic mixing valve having excessive 'dead-legs' of pipework. Such systems can disguise the onset of thermostatic mixing valve malfunction.

Ultimately, the user must exercise due diligence to ensure that the delivery of warm water is at a stable, safe temperature.

Make sure that the water delivery does not cause splashing or overflow.

Allow sufficient projection into the basin by ensuring the tap is mounted close enough to the vessel.

# Specification

General	PSU	Valve
Maximum Ambient Temperature	50°C	40°C
Minimum Ambient Temperature	1°C	1°C
Maximum Humidity	95% rH	95% rH

Electrical	PSU	Valve
Supply Voltage	100 - 240 V 50/60 Hz	12 V DC
Rated Input Current	1 A	2.0 A
Standby Current	0.16 A	0.16 A
Water Ingress Protection	IP X4	IP X4
Protection Against Electric Shock	Class II (double insulated)	Class III (SELV)
Pollution Degree	2	2
Rated Impulse Voltage	2.5 kV	18 V

Performance	
Factory pre-set temperature	39°C
Factory pre-set temperature range	37°C - 41°C
Programmable temperature range	33°C - 45°C (Full cold can be selected during programming)

For Type 3 installations, the supply conditions specified in the TMV3 Requirements manual take precedence over the operating parameters which follow.

Water Supply	
Minimum dynamic pressure	100 kPa (1.0 bar)
Maximum dynamic pressure	500 kPa (5.0 bar)
Maximum static pressure	1000 kPa (10.0 bar)
Supply pressure differential	Equal pressure recommended - inlet pressures must be stable for optimum performance.
Minimum recommended differential between hot supply and outlet temp (consistent with HSE Guidelines)	7°C
Hot supply temp	55°C - 65°C (60°C - 65°C Recommended)
Cold supply temp	1°C - 25°C
Maximum disinfection temperature	85°C

Hereby, Kohler Mira Ltd. declares that the radio equipment type MX1 is in compliance with Directive 2014/53/EU. The full text of the EU declaration of conformity is available at the following internet address: [www.mirashowers.co.uk](http://www.mirashowers.co.uk).

The MX1 operates in the Frequency band 2402 MHz-2480 MHz with a maximum power of 0 dBm.

# Factory Default Settings

RADA App Tile / Section	Adjustable Temperature Variant	Fixed Temperature Variant	Range		Units
			Min Value	Max Value	
<b>1. Valve Setup / 4. Installation Setup</b>					
1. Setup Advice	Info Field				
2. Valve Identity	Editable Text Field				
3. Outlet Type and Sub Type	Info Field				
4. Unit Address	17	17	1	31	
5. Valve Date and Time	24 Hr Clock			DD/MM/YYYY	
6. Last Service and Time	Info Field				
7. Flow Calibration					
8. Minimum Flow Limit	5	5	1	100	
9. Maximum Flow Limit	13	13	1	100	
10. Valve DOB	Info Field				
11. Calibration	N/A Set to max 300, 300				
12. IR Calibration	Factory Programmed - typical Range 180 - 220				
13. Pin	0001 - 9999 Permissible. Re-entry of 5945 Not Permitted				
14. Tap Interface	Info Field				
15. Operational State	Enable	Enable	Enable, Disable		
16. Tasks	Apply Changes to Valve / Undo Changes				
<b>1. Valve Setup / 5. Outlet Setup</b>					
1. Type	Info Field				
2. Sub Type	On/Off	On/Off	(On/Off), Timed Blocking		N/A
3. Outlet Selection	Info Field				
4. Full Cold Mode	Disabled	Disabled	Start Cold Enabled Disabled	Start Cold Enabled Disabled	
5. Minimum Temperature	37	N/A	33	45	0.5 deg C
6. Default Temperature	39	38	33	45	
7. Maximum Temperature	41	N/A	33	45	0.5 deg C
8. Flow Rate Setup	N/A				
9. Default Flow Rate	50	50	10	100	%
10. Outlet Timeout	5 Min	5 Min	0s	30 Min	Seconds / min
11. Run on Time	5 S	5 S	1	60	Seconds
12. Temperature Memory	40 S	N/A	0	5 Min	Seconds / min
13. Blocking Time	1	1	1	25 Min	Seconds / min
14. Temperature Scale	9 Increments	N/A	9, 5 Increments)		
15. Tasks	Apply Changes to Valve / Undo Changes				
<b>1. Valve Setup / 6. Duty Flush Setup</b>					
1. Activation	Manual	Manual	Manual, Automatic		

2. Type	Standard	Standard	Disabled, Standard, Standard oscillation	Disabled, Standard, Standard oscillation	
2. Type	Standard	Standard	Disabled, Standard, Standard Oscillation, Smart, Smart Oscillation	Disabled, Standard, Standard Oscillation, Smart, Smart Oscillation	
3. Activation Time	02:00 Hrs	02:00 Hrs			Time 24 Hr Clock
4. Duration	1 Min	1 Min	1 S	25 min	Seconds / Min
5. Frequency	1 Per 3 Days	1 Per 3 Days	1 Hr	1 Week	Hrs / day / 1 Week
6. Schedule	Auto Populated Field				
7. Temperature	39	39	37	41	deg C
8. Flow Rate	100	100	10	100	%
9. Warm Up Time	1 Min	1 Min	1 S	25 Min	Seconds / Min
10. Post Cold Flush	0	0	0	10	Seconds / min
11. Tasks	Apply Changes to Valve / Undo Changes				
<b>1.Valve Setup / 7. Cold Flush Setup</b>					
1. Activation	Manual	Manual	Manual, Automatic		
2. Type	Disabled	Disabled	Disabled, Standard		
3. Activation Time	04:00 Hrs	04:00 Hrs			Time 24 Hr Clock
4. Duration	2 Mins	2 Mins	5 S	10 Mins	Seconds / Min
5. Frequency	1 Per 3 Days	1 Per 3 Days	1 Hr	1 Week	Hrs/Day/1Week
6. Schedule	Auto Populated Field				
7. Cool Down Temperature	19	19	15	<= Maintain Temperature	deg C
8. Maintain Temperature	20	20	15	30	deg C
9. Cool Down Timeout	2 Mins	2 Mins	5 S	10 Mins	Seconds / Min
10. Flow Test	Start / Stop				
11. Flow Rate	100	100	10	100	%
12. Task	Apply Changes to Valve / Undo Changes				
<b>1. Valve Set Up / 8. Thermal Disinfection Setup</b>					
1. Activation	Manual	Manual			
2. Type	Disabled	Disabled	Disabled, Standard, Exponential, Standard Cold, Exponential Cold		
3. Duration	20	20	1	30	Mins
4. Minimum Temperature	60	60	60	<=Upper	deg C
5. Upper Temperature	60	60	>=Lower	80	deg C
6. Flow Rate	10	10	10	100	%
7. Warm Up Time	5	5	1	20	Mins
8. Timeout	30	30	1	59	Mins

\* Flow rates are limited by the supply regulation of 2 L/min hot and cold 4 L/min.

# Pack Contents

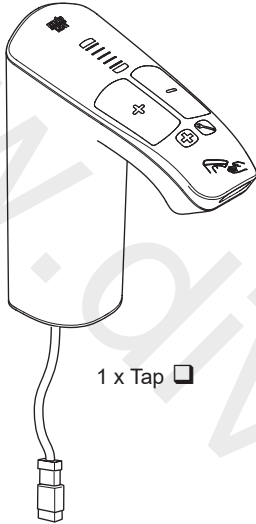

1 x Tap

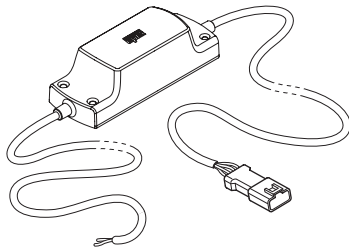

1 x Power Supply

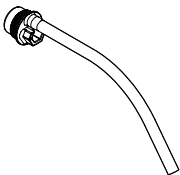

1 x Flush Pipe

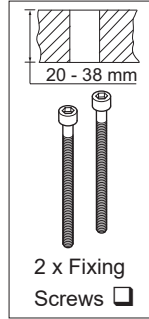

2 x Fixing Screws

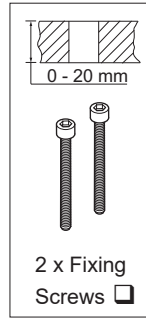

2 x Fixing Screws

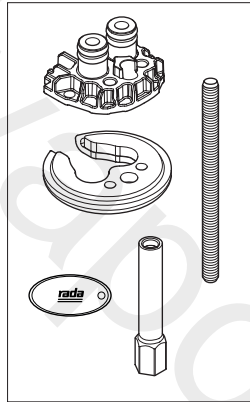

1 x Tap Fixing Kit

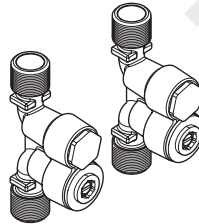

2 x Inlet Unit Assemblies



4 x Olives (15 mm)

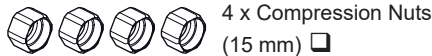

4 x Compression Nuts (15 mm)



2 x Flexible Tails



2 x Washers



2 x Reducers

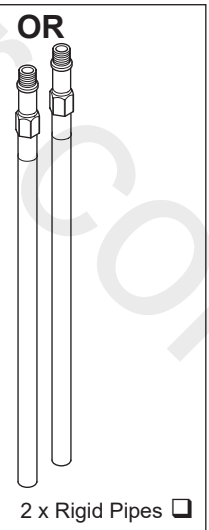

2 x Rigid Pipes

## Inlet Unit - Important

**Failing to install the inlet units will cause product damage, invalidate the product's warranty and the product will no longer be TMV3 compliant.**

The inlet unit is an integral component of the product consisting of a Filter / Flow Regulator/ Check valve / Isolator.

The units are specific to hot and cold supplies, identified by a red / blue indices.

Flow direction is critical and is identified by the arrow on the unit's body.

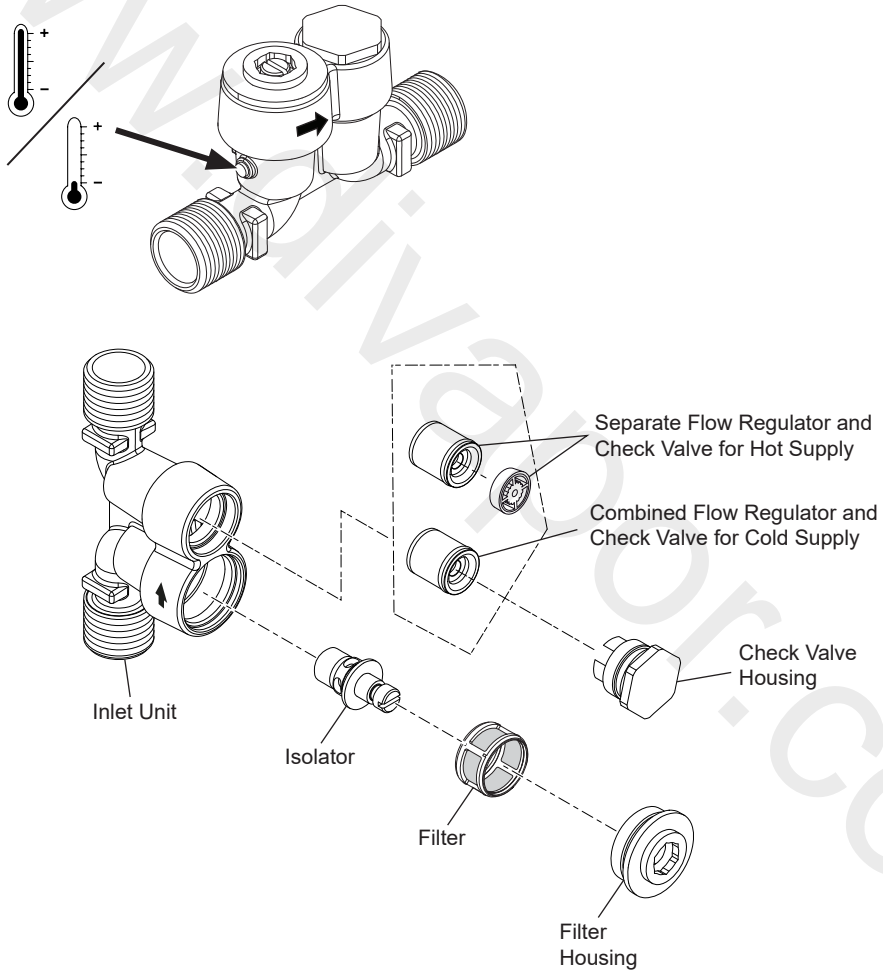

Filter contained in the unit is a fine 150 micron stainless steel mesh.

The flow regulators are included to ensure the tap delivers a uniform flow and must remain in situ for correct performance.

# Dimensions

## MX1 20

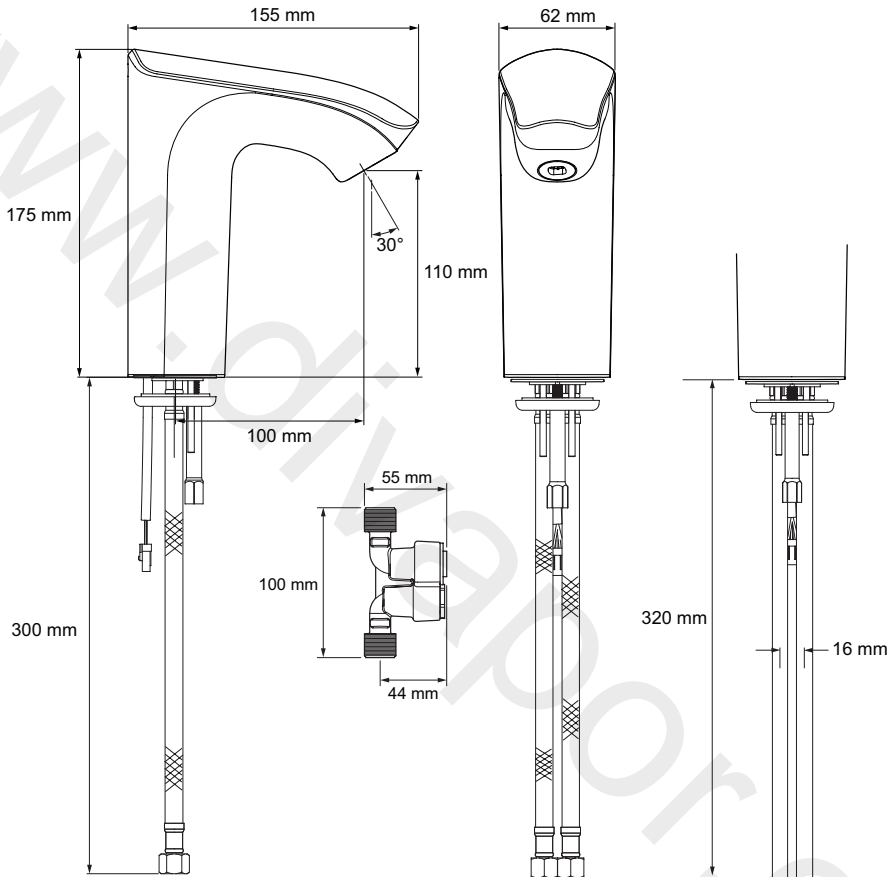



## MX1 40

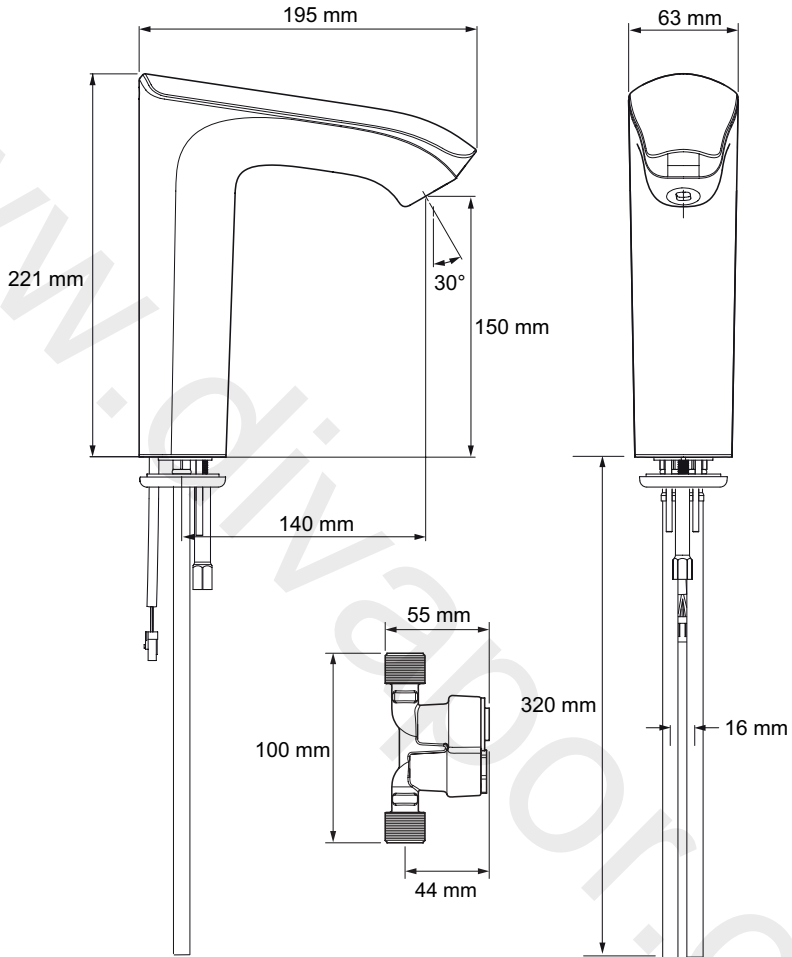

## Power Supply Unit (PSU)

Make sure that you install the PSU in an area that you can access easily for servicing and maintenance purposes.

Ensure plugs and sockets are completely dry before making any connection, including any accidental water contact.

Ensure connections are not in an area exposed to excessive moisture or condensation.

**DO NOT** exceed the maximum cable run of 3.59m, doing so would invalidate electrical approval.

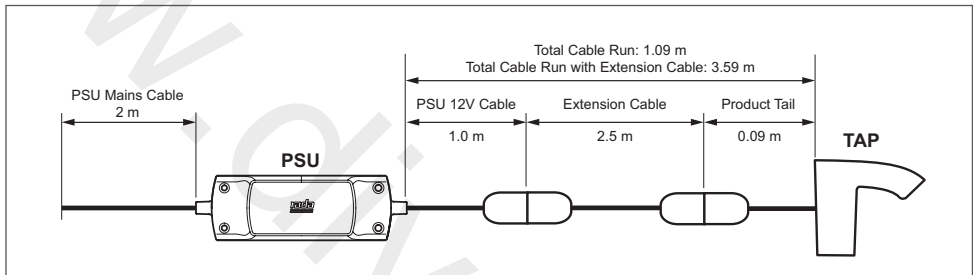

## Disposal and Recycling

### End of Product Life

Electrical and electronic devices contain a range of materials that can be separated for recycling and used in new products.



This product should not be disposed of with your general household waste. When this product has reached the end of its serviceable life, please remove any batteries and take it to a recognised WEEE (Waste Electrical and Electronic Equipment) collection facility such as your local civic amenity site for recycling.

Your local authority or retailer will be able to advise you of your nearest recycling facility.

# Installation Requirements

The Rada MX1 basin mounted tap can be installed with either flexible tails or rigid pipes. Refer to the installation schematics below:

## Installation with Rigid Pipes

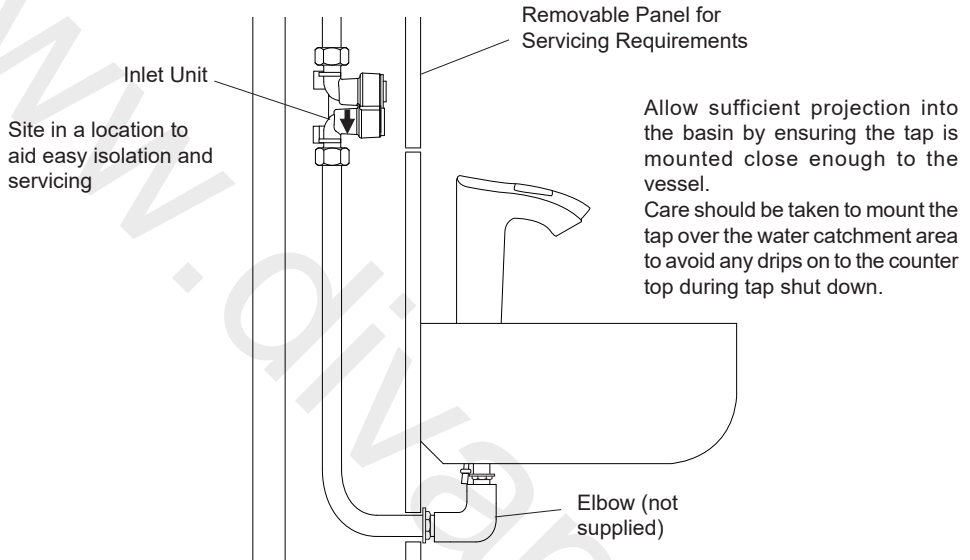

## Installation with Flexible Tails

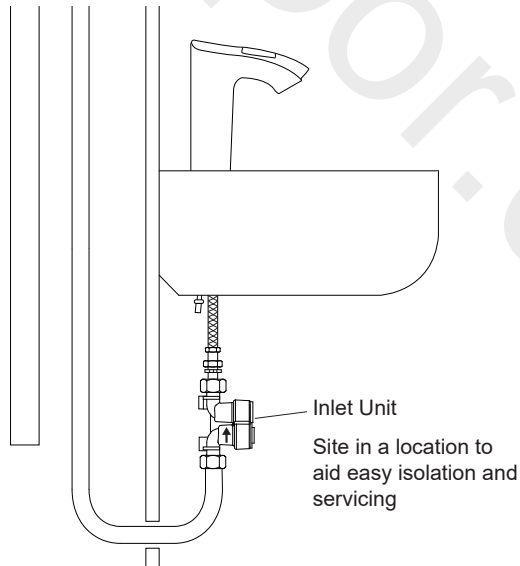

# Installation

1

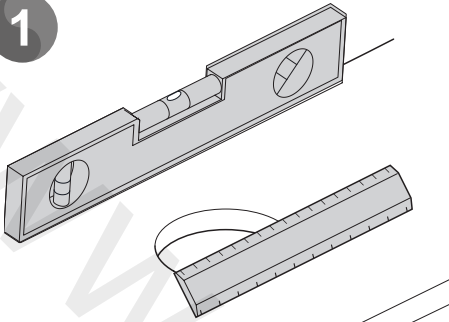

Measure the size of the basin hole.

2

> 34 mm

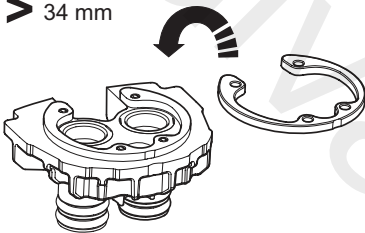

If the basin hole is greater than 34 mm, fit the plastic spacer.

< 34 mm

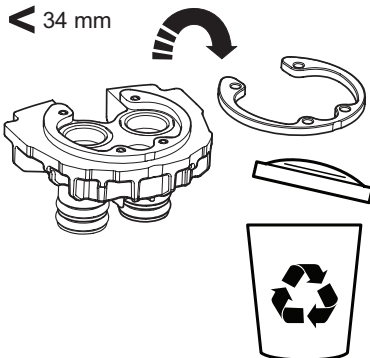

If the basin hole is smaller than 34 mm, discard the plastic spacer.

3

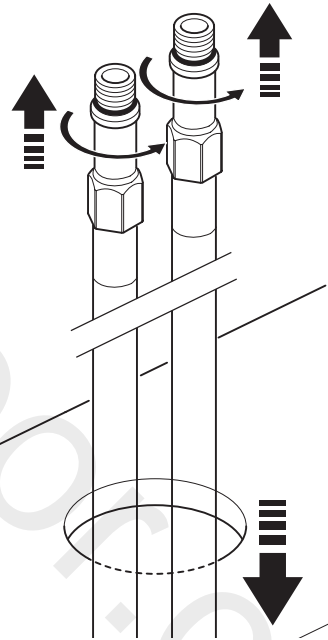
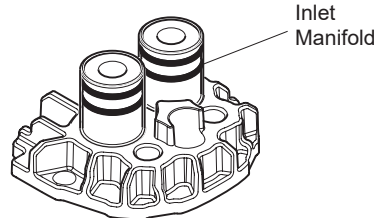

**Note:** The inlet manifold **MUST** be a watertight fit to the basin.

Install the flexible tails or rigid pipes.

4

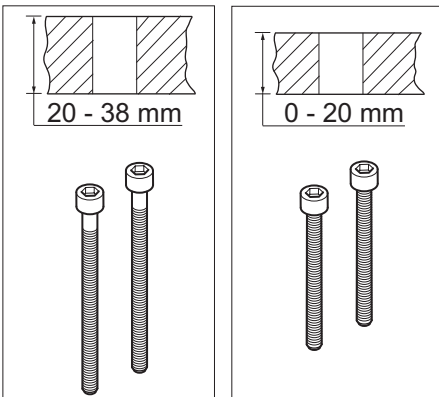
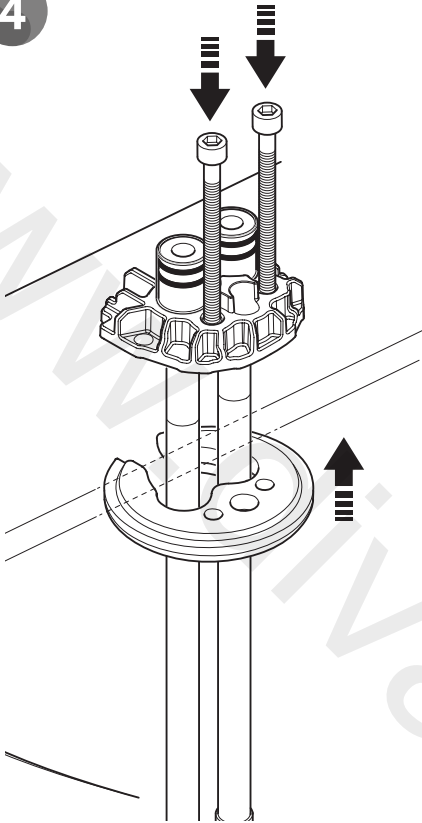

Select the screws to suit the thickness of the washbasin.

**Note:** Screws **MUST** be fitted.

5

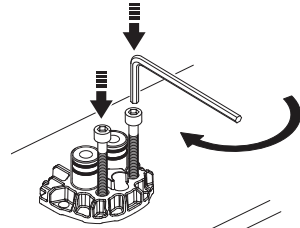

Tighten the screws using a 3 mm hexagonal wrench.

6

### a Flexible Tails

The inlet units are identified by a coloured dot that indicates hot and cold connections.

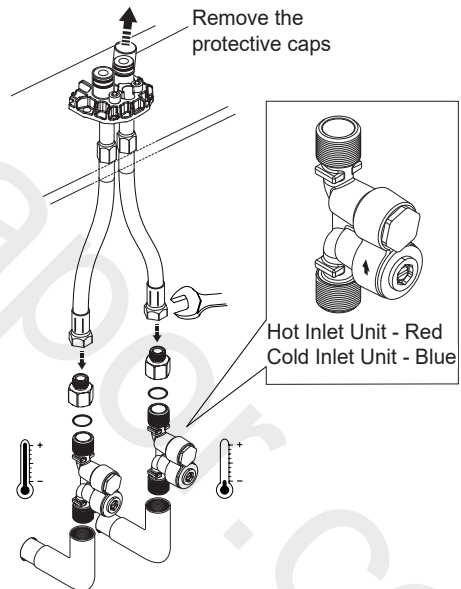

Connect to the water supplies using the supplied inlet units. The inlet units **MUST** be connect to the tails.

**DO NOT** use jointing paste when making plumbing connections.

**Note:** Make sure that the inlet units are installed in the correct orientation. An arrow indicates the direction of water flow.

6

b

## Rigid Pipes

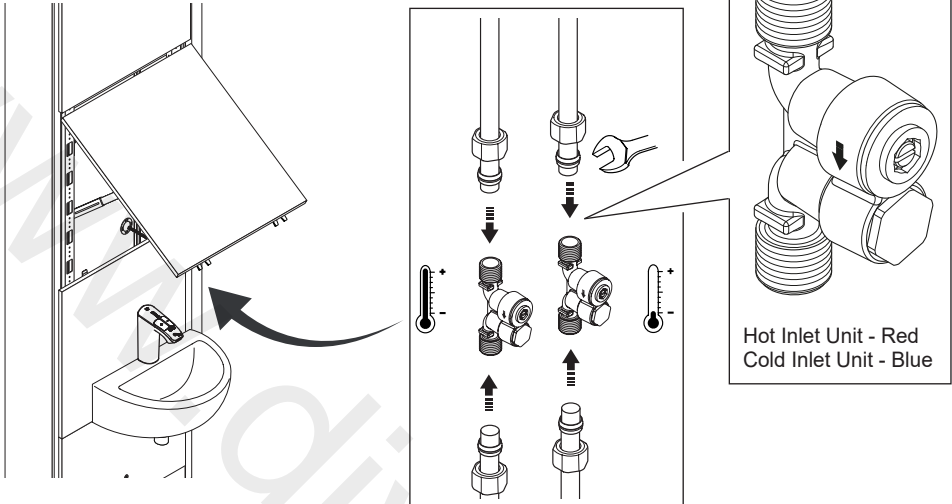

The inlet units are identified by a coloured dot that indicates hot and cold connections. This assembly to be sited in a location that is accessible for servicing. Maximum pipe length between inlet units and tap is 2 meters.

Connect to the water supplies using the supplied inlet units.

**DO NOT** use jointing paste when making plumbing connections.

**Note:** Make sure that the inlet units are installed in the correct orientation. Arrow indicates the direction of water flow.

7

## Flush the Pipework

a

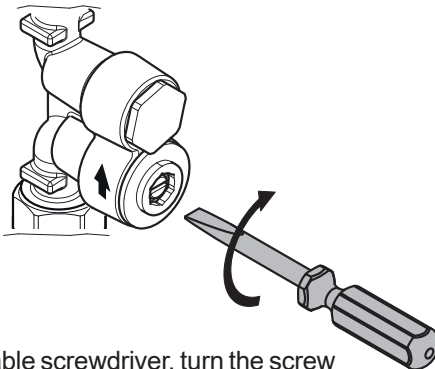

Using a suitable screwdriver, turn the screw fully clockwise to isolate the water supply to the tap.

b

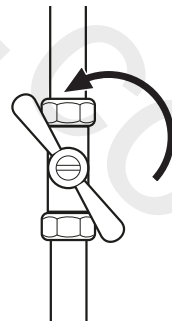

Reinstate the supply to the inlet units.

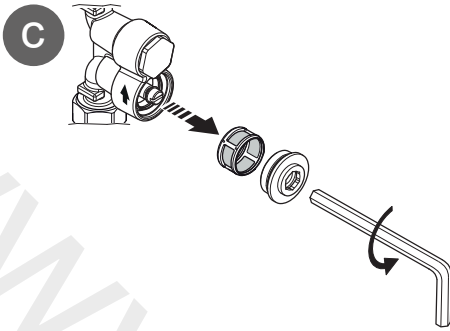

Using a 10 mm hexagonal wrench, unscrew and remove the filter.

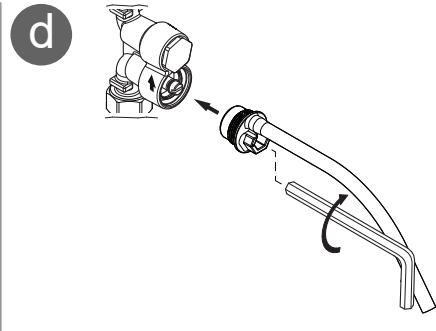

Install the bleed pipe and tighten using a 10 mm hexagonal wrench.

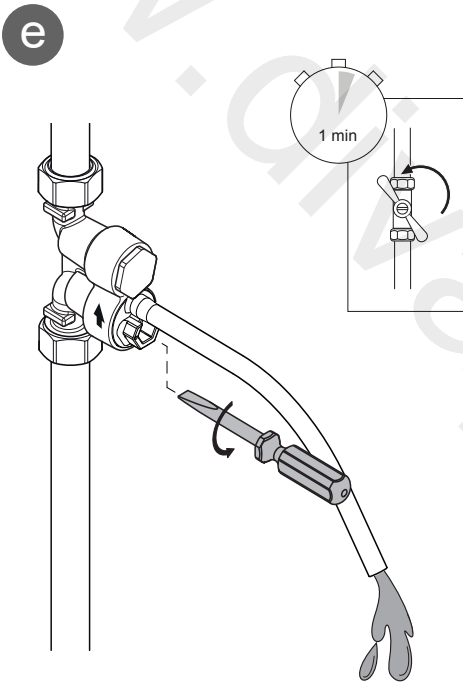

Using a suitable screwdriver, unscrew the screw to bleed the supply pipework.

After bleeding, refit the components in reverse order. **DO NOT** open the isolator on the inlet units.

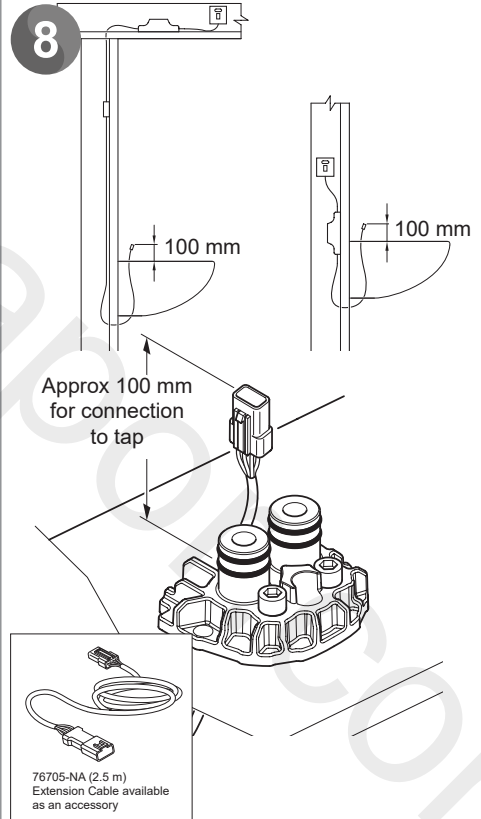

**Note:** Make sure that you install the PSU (Power Supply Unit) in an area that you can access easily for servicing and maintenance purposes. Ensure this area is free from moisture.

9

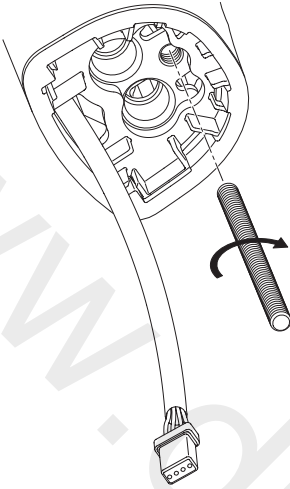

10

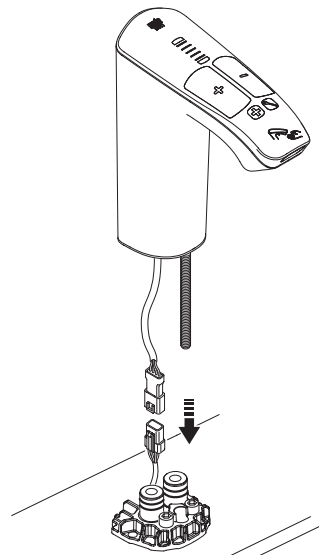

11

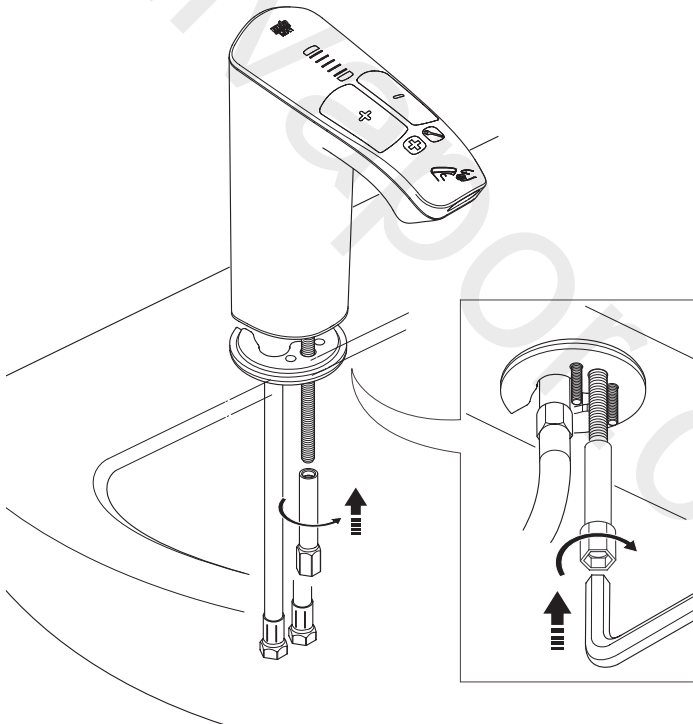

Tighten the nut using a 6 mm hexagonal wrench.



12

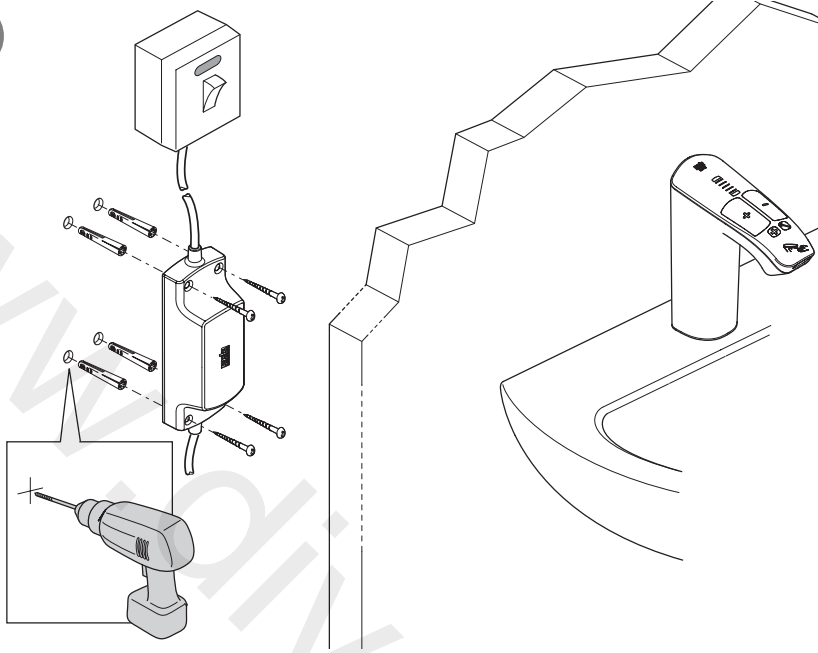

Install the PSU (Power Supply Unit) in an area that you can access easily for servicing and maintenance purposes. Open the isolator on the inlet unit.

13

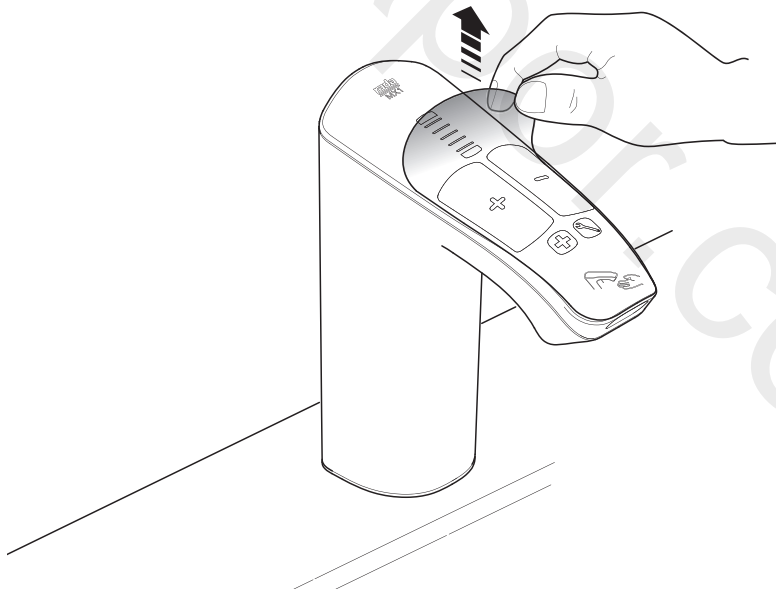

## Commissioning

The Rada MX1 basin mounted tap will operate to factory settings when first installed. Download the “RADA AP1” from the Apple APP Store and follow the on screen instructions.

**Note:** Run the tap for 30 seconds in order for self calibration to take place.

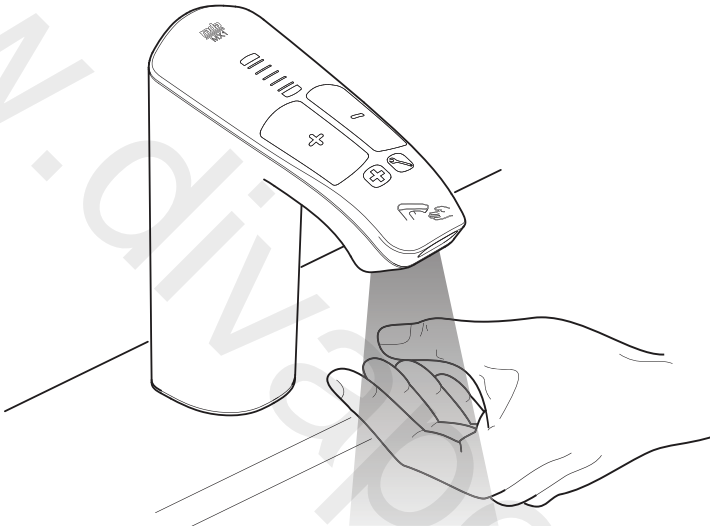

## Operation

The Rada MX1 basin mounted tap will operate to factory settings when first installed. Download the “RADA AP1” from the Apple APP Store and follow the on screen instructions.

MX1 is a no touch device, flow operation and temperature adjustment can be made without touching the tap.

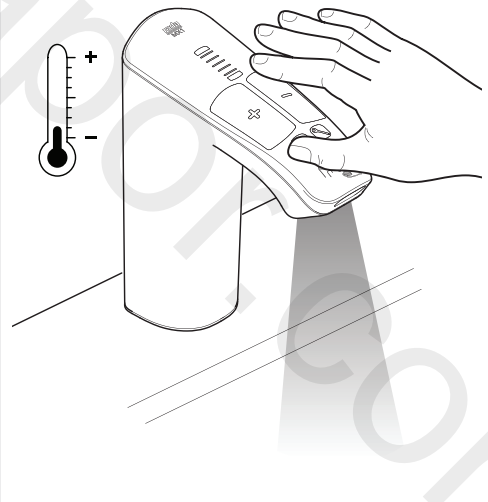
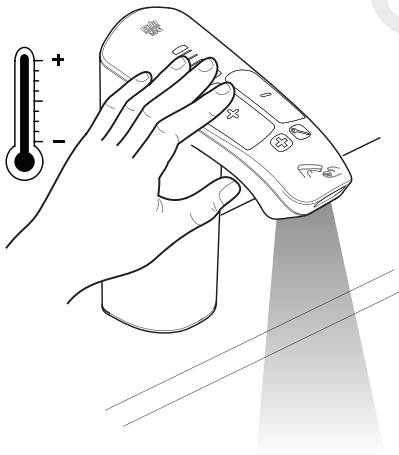
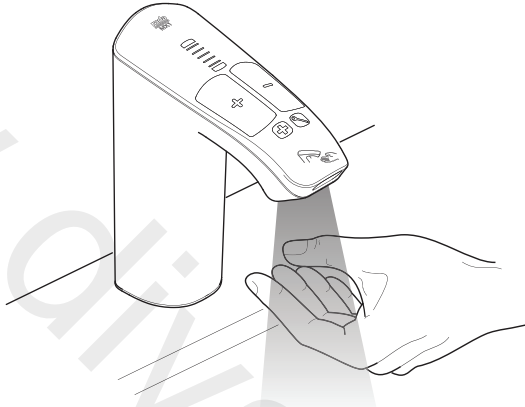
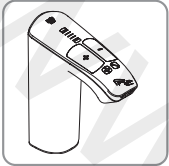

**Note:** For Type 3 valves in UK Healthcare installations the maximum blend temperature is determined by the application, refer to the TMV3 Requirements Manual which is available to view or download from our website [www.radacontrols.com](http://www.radacontrols.com).

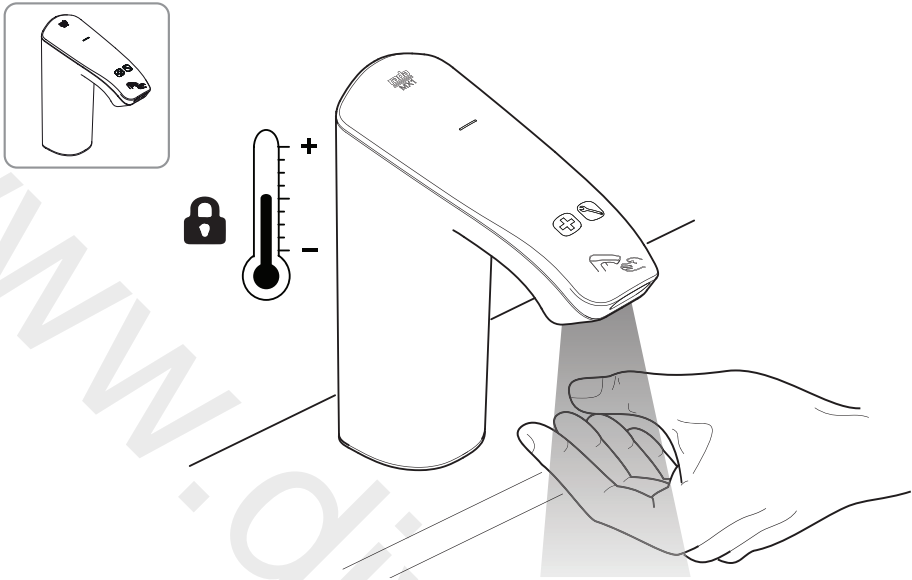

**Note:** This tap has an over temperature limiting device, should blend temperature exceed safe conditions, the valve will shut down and reset automatically once temperature returns to a safe state.

# Fault Diagnosis

As with most electronic equipment re-setting the mixing valve by powering it down at the mains, waiting a few seconds and powering it up again can often cure any issues.

<i>Symptoms</i>	<i>Probable Cause</i>	<i>Possible Remedy</i>
No water flow / will not turn on	Product has entered an error mode indicated by a flashing “ <b>spanner</b> ” symbol	Refer to Error Log
	Product in programming / cleaning mode	Use magnetic key to put the Digital Mixing Valve back in to normal operational mode.
	No power to the Digital Mixing Valve	Check electrical connection and power supply. Ensure no moisture is present on the power supply connections. Re-set the product by turning electrical supply off for 30 seconds then re-apply power.
	Inlet unit water supply isolators not fully open	Check and remedy.
	Inlet water supply failure	Check and remedy.
	Inlet unit filters or check valves blocked	Check and remedy.
	Inlet unit installed the wrong way around	Check and remedy.
	Outlet spout, hose or handset blocked	Check and remedy.
	Reversed inlet supplies	Check and remedy.
	Inlet water pressure too low	Check specification.
	“ <b>Blocking</b> ” time set	Commission “ <b>Blocking</b> ” time using the “ <b>RADA AP1</b> ”.
	Digital Mixing Valve air locking	Check for correct installation practices, repeat commissioning procedure and rearrange pipework to avoid airlock forming.
Digital Mixing Valve failure	Contact Rada.	

<b>Symptoms</b>	<b>Probable Cause</b>	<b>Possible Remedy</b>
Flow rate too low	Inlet unit isolators not fully open	Check and remedy.
	Inlet unit filters or check valves blocked	Check and remedy.
	Outlet spout, hose or handset blocked	Check and remedy.
	Reversed inlet supplies	Check and remedy.
	Inlet Water pressures too low	Check specification.
	Digital Mixer valve air locking	Check for correct installation practices, repeat commissioning procedure and rearrange pipework to avoid airlock forming.
	Digital Mixing Valve failure	Contact Rada.
Flow rate too high	Inlet water pressures too high	Check specification.
	Inlet unit not fitted	Check and remedy.
	Digital Mixing Valve failure	Contact Rada.
Outlet flow rate fluctuates	Inlet unit filters or check valves blocked	Check and remedy.
	Outlet spout, hose or handset blocked	Check and remedy.
	Reversed inlet supplies	Check and remedy.
	Inlet water supply pressures are unstable or imbalanced	Ensure the water supply pressures are stable and nominally equal, refer to <b>“Specifications”</b> .
	Digital Mixing Valve air locking	Check for correct installation practices, repeat commissioning procedure and rearrange pipework to avoid airlock forming.
	Digital Mixing Valve failure	Contact Rada.

<b>Symptoms</b>	<b>Probable Cause</b>	<b>Possible Remedy</b>
Keeps cutting out	Product has entered an error mode indicated by a flashing “ <b>spanner</b> ” symbol	Refer to Error Log.
	Inlet unit water supply isolators not fully open	Check and remedy.
	Inlet unit filters or check valves blocked	Check and remedy.
	Outlet spout, hose or handset blocked	Check and remedy.
	Reversed inlet supplies	Check and remedy.
	”Run time” is set too short.	Commission the run time using the “ <b>RADA AP1</b> ”.
	“ <b>Blocking</b> ” time set	Commission “ <b>Blocking</b> ” time using the “ <b>RADA AP1</b> ”.
	Digital Mixer valve air locking	Check for correct installation practices, repeat commissioning procedure and rearrange pipework to avoid airlock forming.
	Digital Mixing Valve failure	Contact Rada.
	Inlet pressures and/or temperatures are unstable or spiking	Check and remedy, refer to “ <b>Specifications</b> ”.
Outlet temperature too cool	Temperature adjustment set too low	Increase temperature control - Some models only
	Blend temperature set too low	Re-commission blend temperature using “ <b>RADA AP1</b> ”.
	Inlet unit filters or check valves blocked	Check and remedy.
	Outlet spout, hose or handset blocked	Check and remedy.
	Reversed inlet supplies	Check and remedy.
	Hot inlet water supply temperature is too cool	Increase hot inlet water temperature to between 55 °C and 65 °C, refer to “ <b>Specifications</b> ”.
	Insufficient quantity of stored hot water	Hot water supply running out, increase storage capacity.

<b>Symptoms</b>	<b>Probable Cause</b>	<b>Possible Remedy</b>
Outlet temperature too cool (Continued)	Inlet water supply pressures are unstable or imbalanced	Ensure the water supply pressures are stable and nominally equal, refer to “ <b>Specifications</b> ”.
	Outlet pipe run is too long	Ensure outlet pipe work is thermally lagged.
	Digital Mixing Valve failure	Contact Rada.
Outlet temperature is too hot or fluctuates	Temperature adjustment set too high	Decrease temperature control - Some models only.
	Blend temperature set too high	Re-commission blend temperature using “ <b>RADA AP1</b> ”.
	Hot inlet water supply temperature is too hot	Reduce hot inlet water temperature to between 55 °C and 65 °C, refer to “ <b>Specifications</b> ”.
	Inlet unit filters or check valves blocked	Check and remedy.
	Outlet spout, hose or handset blocked	Check and remedy.
	Reversed inlet supplies	Check and remedy.
	Fluctuating supply pressures and / or temperatures	Check and remedy.
	Inlet water supply pressures are unstable or imbalanced	Ensure the water supply pressures are stable and nominally equal, refer to “ <b>Specifications</b> ”.
	Temperature affected by use of adjacent hot/cold outlet. Insufficiently sized pipe work to feed both Digital Mixer Valve and additional outlets at the same time.	Increase pipe sizes or separately feed to the product.
	Digital Mixing Valve failure	Contact Rada.
No shut off / Continuous flow	Run on time set too long	Re-commission the run on time using the “ <b>RADA AP1</b> ”.
	Possible debris in Digital Mixing Valve	Power cycle the digital mixer (turn off and on again). Ensure inlet filters are clean.
		Perform a temperature check using the “ <b>RADA AP1</b> ” to flush debris from the Digital Mixing Valve.
	Digital Mixing Valve failure	Contact Rada.



<b>Symptoms</b>	<b>Probable Cause</b>	<b>Possible Remedy</b>
Noise	The product will make a mechanical noise during (and just after) normal operation	
	Digital Mixing Valve air locking	Check for correct installation practices, repeat commissioning procedure and rearrange pipework to avoid airlock forming.
	Water Hammer	Ensure all pipework is securely fixed.
	Amplified acoustic noise from the Digital Mixing Valve mechanism due to structure of the mounting	The type of wall or surface the appliance is fixed to will affect the perceived noise level; solid walls will provide a quieter operation.
	Digital Mixing Valve failure	Contact Rada.
False triggering	Protective film not removed from product	Remove protective film.
	Dirty sensor window	Clean sensor window.
	Reflective surfaces	Infra Red sensors activated by reflective surfaces such as polished basins, Hi-Vis jackets and mirrors.
	Ambient light conditions	Direct sunlight or constant shadowing of the sensors to be reduced.
	Digital Mixing Valve failure	Contact Rada.
Water leaking from product	Damaged seal	Replace seal and re-fit product.
	Product not fully engaged to manifold	Correctly engage product to manifold.
	Digital Mixing Valve failure	Contact Rada.





A flashing “spanner” symbol indicates the product has gone in to an error mode. If repeated errors are logged this **MUST** be diagnosed and corrected by a technician. The “RADA AP1” can be used to disable the valve until fault diagnosis can be made. Using the “RADA AP1”, navigate to the Health Check Page tile 12, to read the error log.

**Note.** The last 10 errors are logged in the units memory.

As with most electronic equipment, re-setting the mixing valve by powering it down at the mains, waiting a few seconds and powering it up again can often cure any issues.

Alternatively navigate to the Health Check Page tile 9 of the “RADA AP1” and press “Clear Valve Error” button to reset the valve.

 <b>Error Log</b>	<b>Probable Cause</b>	<b>Possible Remedy</b>
Over temperature at control Over temperature warning	Non Product fault - Thermistor has seen an unsafe blend temperature and has gone in to a thermal shutdown to protect the user	Valve will self clear fault.
Over temperature at outlet	Inlet unit filters or check valves blocked	Check and remedy.
	Obstruction in inlet water supplies, e.g. kinked inlet hose	Check and remedy.
	Hot inlet water supply temperature is too hot	Reduce hot inlet water temperature to between 55°C and 65°C, refer to “ <b>Specifications</b> ”.
	Inlet unit water supply isolators not fully open	Check and remedy.
	Inlet water supply failure	Check and remedy.
	Outlet spout, hose or handset blocked	Check and remedy.
	Reversed inlet supplies	Check and remedy.
	Fluctuating supply pressures and / or temperatures	Check and remedy.
	Inlet water supply pressures are unstable or imbalanced	Ensure the water supply pressures are stable and nominally equal, refer to “ <b>Specifications</b> ”.
	Blend temperature affected by use of adjacent hot/cold outlet. Insufficiently sized pipe work to feed both Digital Mixer Valve and additional outlets at the same time.	Increase pipe sizes or separately feed the product.
	Digital Mixing Valve failure	Contact Rada.

 <b>Error Codes</b>	<b>Probable Cause</b>	<b>Possible Remedy</b>
Temp imbalance  Unstable supply	Non Product Fault - The supply conditions are out of specification	Valve will self clear fault.
	Hot inlet water supply temperature is too hot or fluctuating	Reduce hot inlet water temperature to between 55°C and 65°C, refer to “ <b>Specifications</b> ”.
	Inlet water supply pressures are unstable or imbalanced	Ensure the water supply pressures are stable and nominally equal, refer to “ <b>Specifications</b> ”.
Motor homing error  Recovered EE error  EE error - reverted to default	Non Product Fault	Re-set the product by turning electrical supply off for 30 seconds then re-apply power.
Open circuit error	Software failure	Re-set the product by turning electrical supply off for 30 seconds then re-apply power.
	Loose internal wiring connections (Thermistor)	Ensure all wiring connections are securely made.
	Thermistor failure	Contact Rada.
Unconfigured  A to D Read Error  RAM error  EE Error  External EE error  RTC Fault  Flash Error  Scheduler Error  IR not calibrated	Software failure	Re-set the product by turning electrical supply off for 30 seconds then re-apply power.
	PCB failure	Contact Rada.
Shut Off Mechanism  Controller Error	Software failure	Re-set the product by turning electrical supply off for 30 seconds then re-apply power.
	Loose internal wiring connections (Solenoid and PCB)	Ensure all wiring connections are securely made.
	Digital Mixing Valve failure	Contact Rada.

 <b>Error Codes</b>	<b>Probable Cause</b>	<b>Possible Remedy</b>
Interface Error Interface CGF error	Software failure	Re-set the product by turning electrical supply off for 30 seconds then re-apply power.
IO expander error	Loose internal wiring connections (Interface and PCB)	Ensure all wiring connections are securely made.
	Interface failure	Contact Rada.

# Maintenance

## Programming / Cleaning Mode

**Caution!** Risk of product damage. Many cleaners contain abrasive and chemical substances, and should not be used for cleaning stainless steel, enamel, plated or plastic fittings. These finishes should be cleaned using a mild washing up detergent or soap solution, rinsed and then wiped dry with a soft clean cloth.

**Note:** Run the tap for 30 seconds in order for self calibration to take place.

### Change the Flow Insert

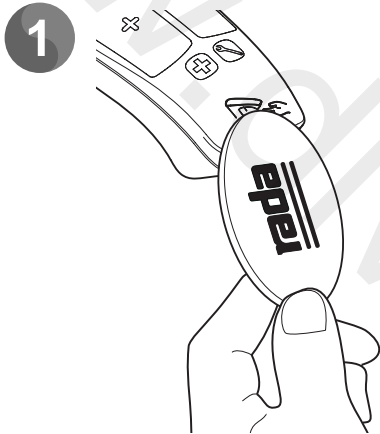

Enter cleaning mode. Scan the Rada key over the spout to enter / exit cleaning mode.

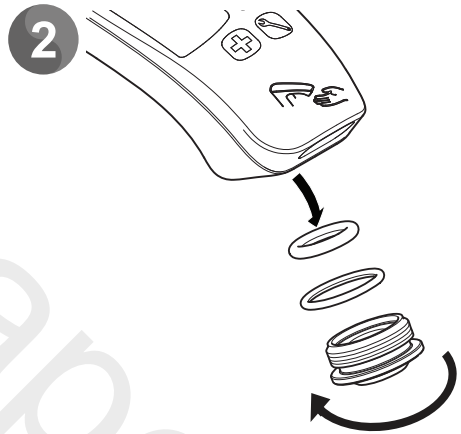

Remove the flow insert using 8 mm hexagonal wrench.

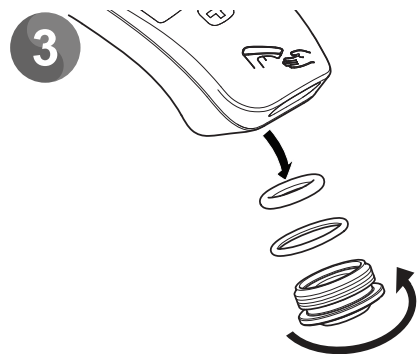

Replace the new flow insert.

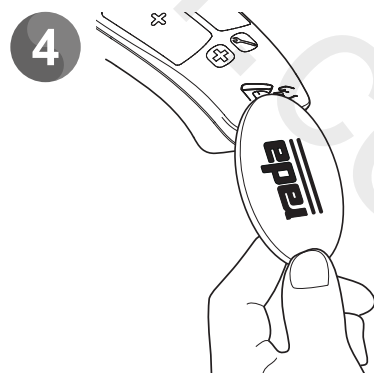

Exit cleaning mode.

## Clean the Filter

1

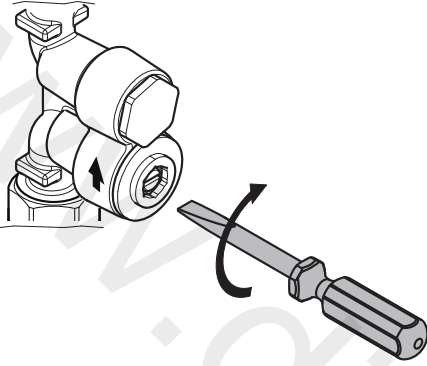

Turn the screw fully clockwise to isolate the water supply.

2

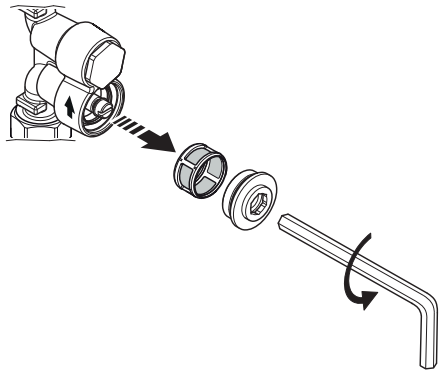

Unscrew and remove the filter.

3

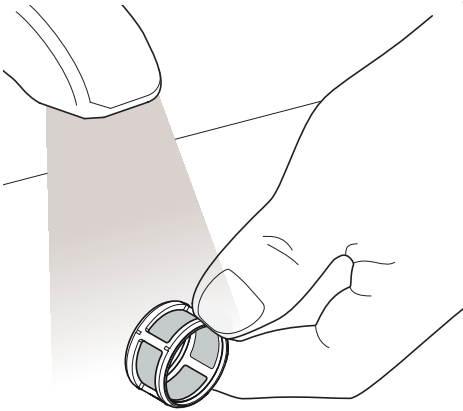

Clean the filter under running water.

4

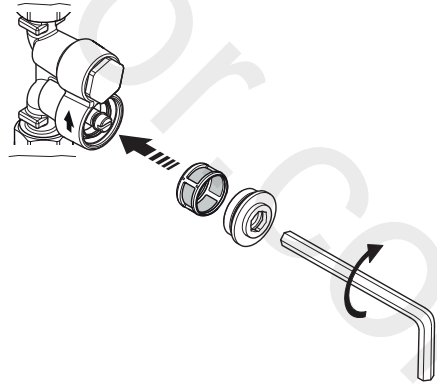

Refit the components in reverse order.

## Replace the Check Valve

1

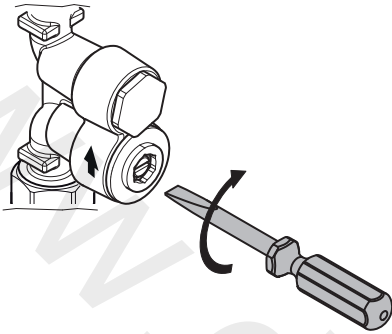

Turn the screw fully clockwise to isolate the water supply. Relieve the pressure by operating the tap.

2

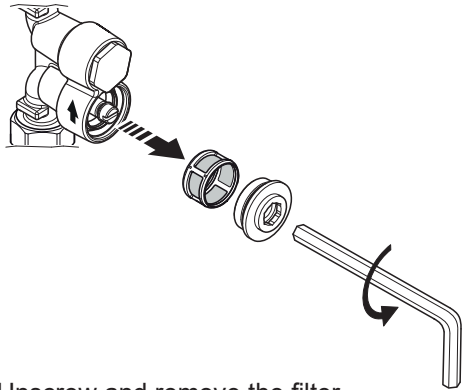

Unscrew and remove the filter.

**Note:** Filter **MUST** be removed to remove the check valve housing.

3

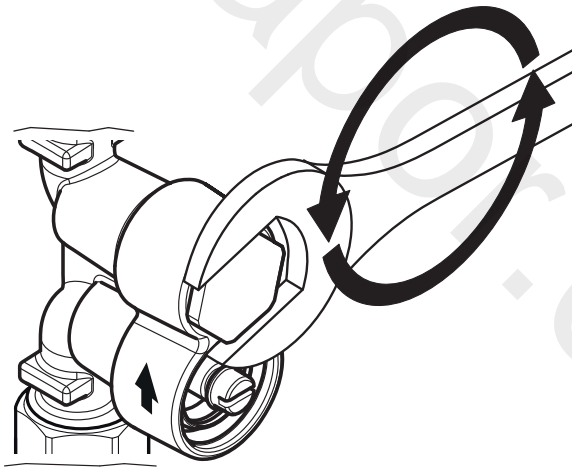

Using a suitable spanner, remove the check valve housing.

## 4 a Cold Supply - Blue Indices

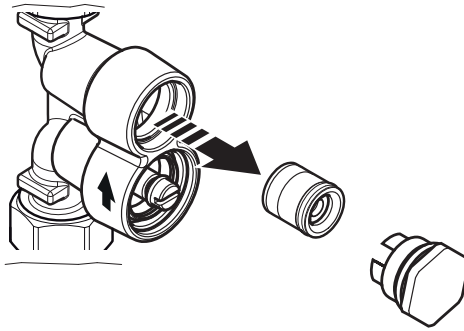

Remove the combined flow regulator / check valve and replace.

Refit all the components in reverse order.

Check valves are non-serviceable and must be discarded and replaced with new items.

Refit, noting that the pin on the plunger will face into the inlet unit.

## b Hot Supply - Red Indices

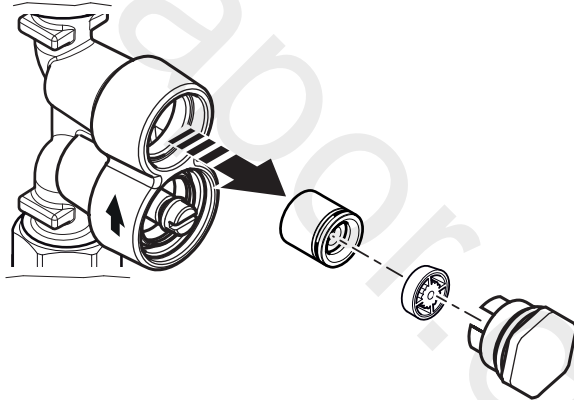

Remove the flow regulator and check valve. Make a note of the orientation of these components, this is critical to the unit operation.

Refit all the components in reverse order.

Check valves are non-serviceable and must be discarded and replaced with new items.

Refit, noting that the pin on the plunger will face into the inlet unit.



# Spare Parts

**1264086**  
(74010-CP)

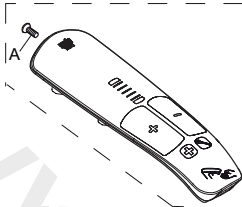

**1264126**  
(72940-CP,  
72942-CP)

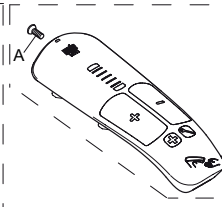

**1264133**  
(72941-CP,  
72943-CP)

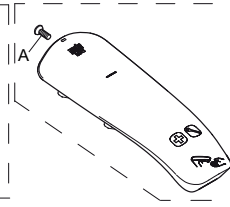

**1264128 (no temp)**  
(72941-CP,  
72943-CP)

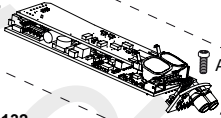

**1264132**  
(72940-CP,  
72941-CP,  
72942-CP,  
72943-CP)  
**1264093**  
(74010-CP)



**1264087**  
(72940-CP,  
72941-CP,  
72942-CP,  
72943-CP)  
**1264088**  
(74010-CP)

**1264094**  
(72940-CP,  
72941-CP,  
72942-CP,  
72943-CP)  
**1264125**  
(74010-CP)

**1264127 (temp)**  
(74010-CP,  
72940-CP,  
72942-CP)

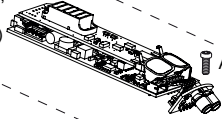

**1264124**  
(72940-CP,  
72941-CP,  
72942-CP,  
72943-CP)

**1264079**  
(74010-CP)

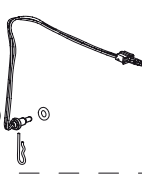

**1264090**  
(72940-CP,  
72941-CP,  
72942-CP,  
72943-CP)  
**1264089**  
(74010-CP)

**1264095**

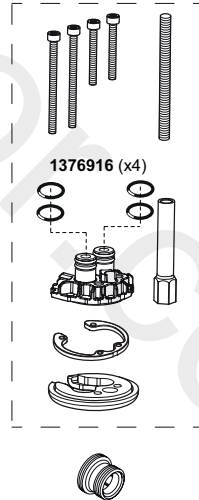

**1264102**  
(72940-CP,  
72941-CP,  
72942-CP,  
72943-CP)  
**1264103**  
(74010-CP)

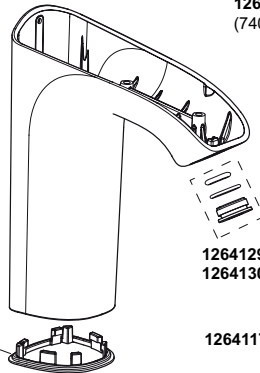

**1264129 (x1)**  
**1264130 (x10)**

**1264117 - Screw Pack 'A'**

**1664.234**  
Pall Filter Connector

# Spare Parts

2L/min HOT - 1370884  
 4L/min COLD - 1370885

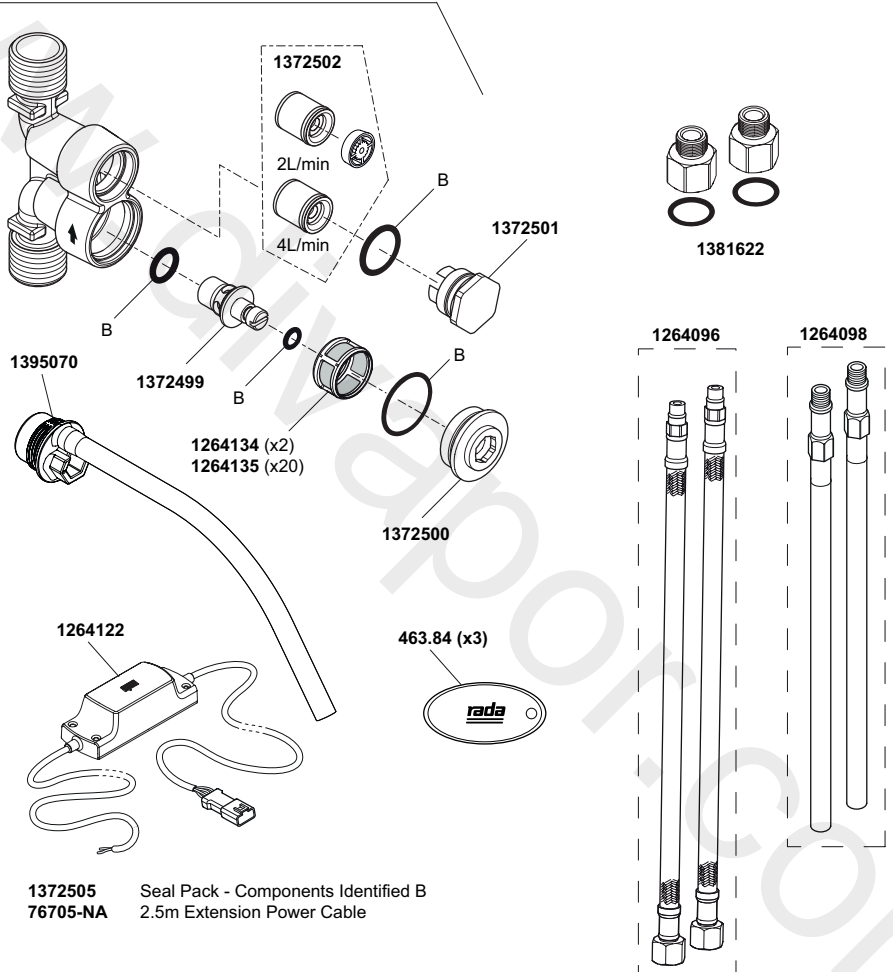

**1372505** Seal Pack - Components Identified B  
**76705-NA** 2.5m Extension Power Cable

# Notes

www.divapor.com

# Customer Service

## Customer Services Guarantee

Your product has the benefit of Rada's comprehensive parts and labour manufacturer's guarantee which commences from date of purchase. Full guarantee terms and conditions can be found at [www.radacontrols.com](http://www.radacontrols.com) or contact your in region Rada representative or sales agent for further details.

## Contact Us

If your product is not working correctly please refer to this manual for fault diagnosis and to check that it is installed and commissioned in accordance with our instructions. If this does not resolve the issue, then please contact our specialist teams who will be happy to help.

### For UK based customers support please contact Rada Customer Services

T: + 44 (0)344 571 1777 Please note: UK calls cost 7p per minute plus your phone company's access charge

E: [RadaCustomerServices@RadaControls.com](mailto:RadaCustomerServices@RadaControls.com)

[www.radacontrols.com](http://www.radacontrols.com)

### For customers based in the Republic of Ireland please contact our Rada Service agent

T: + 353 (0) 1 531 9337

E: [CustomerServiceEire@mirashowers.com](mailto:CustomerServiceEire@mirashowers.com)

For customers based in all other geographical regions please get in touch with your local Rada representative or agent whose contact details can be found by visiting our website [www.radacontrols.com/en/contact-us/find-a-partner](http://www.radacontrols.com/en/contact-us/find-a-partner)

## Services

Our UK Rada Customer Service Team can provide **pre-specification** information as well as details on the **UK Rada product Commissioning Service and Maintenance Service Plans** whilst our nationwide team of field-based technicians are here to help if you need a **Reactive Service Call**. We stock a full range of Rada spare parts and fittings which can be purchased over the telephone.

**Note!** Regional services do vary please speak to your Rada representative or Sales agent for information on service provisions provided in your area.

*Rada is a registered trade mark of Kohler Mira Limited.*

*The company reserves the right to alter product specifications without notice.*

Registered Office:  
Cromwell Road,  
Cheltenham,  
Gloucestershire  
GL52 5EP

EU Importer address  
K/E S.A.S.  
3 rue de Brennus,  
93631, La Plaine Saint-Denis,  
France

