



# SWADLING

## BRASSWARE

Invincible Single Exposed Valve  
Installation manual



7400



7409

Before disposing of the carton and commencing installation, please check all parts against the parts list on back page. Please contact us immediately if any parts are missing or damaged.

Swadling Brassware, Churchward Road, Yate, Bristol, BS37 5PL  
Telephone: 02392 255536 Email: tech@swadlingbrassware.co.uk

**IMPORTANT**

Please read complete installation instructions before fitting.  
Specification. TMV2 valve for use with High and Low Pressure

Condition of use for type 2 valve	High Pressure	Low Pressure
Maximum static pressure	10 Bar	10 Bar
Flow pressure Hot and Cold	0.5 to 5.0 Bar	0.1 to 1 Bar
Hot Supply Temperature	55 to 65 °C	55 to 65 °C
Cold Supply Temperature	Equal to or less than 25 °C	Equal to or less than 25 °C

Valves operating outside these conditions cannot be guaranteed by the Scheme to operate as Type 2 valves.

For Dynamic flow pressures above 6 bar fit pressure reducers.

Maximum Dynamic flow pressure ratio between hot & cold inlet supplies = 5:1

Optimum performance is achieved when hot and cold inlet pressures are nominally balanced to within 10% of each other.

The shower mixer can accept temporary elevated temperatures to 85°C without damage.

Hot water storage temperatures should be maintained between 60-65°C.

#### Recommended outlet temperatures

44°C for bath fill see notes below

41°C for showers

41°C for washbasins

38°C for bidets

Mixed water temperatures must never exceed 46°C. The maximum mixed water temperature can be 2°C above the recommended maximum set outlet temperatures.

#### Note:

46°C is the maximum mixed water for a bath tap. The maximum temperature takes account of the allowable temperature tolerances inherent in thermostatic mixing valves and temperature losses in metal baths. It is not a safe bathing temperature for adults or children.

The British Burns Association recommends 37 to 37.5°C as a comfortable bathing temperature for children. In premises covered by Care Standards Act 2000, the maximum mixed water outlet temperature is 43°C.

The thermostatic mixing valve must be installed in such a position that maintenance of the TMV and its valves and the commissioning and testing of the TMV can be undertaken.

SEE SETTING TEMPERATURE - Commissioning notes.

The valve is suitable for all water systems including Gravity fed, Pumped Systems, Combination Boilers, Condensing Boilers, Mains Pressure fed Systems. However if used in low pressure gravity feed installations to maximize flow rates use 22mm pipe work reducing to 15mm close to the inlets for the HOT and COLD supplies.

Fit isolation valves as close as is practicable to both the HOT and COLD inlet supplies.

**DIMENSIONS  
CONFIGURATION**

**MAX Pressure =  
5.0 BAR  
Fit Pressure reducing  
Valves above 5.0 BAR**

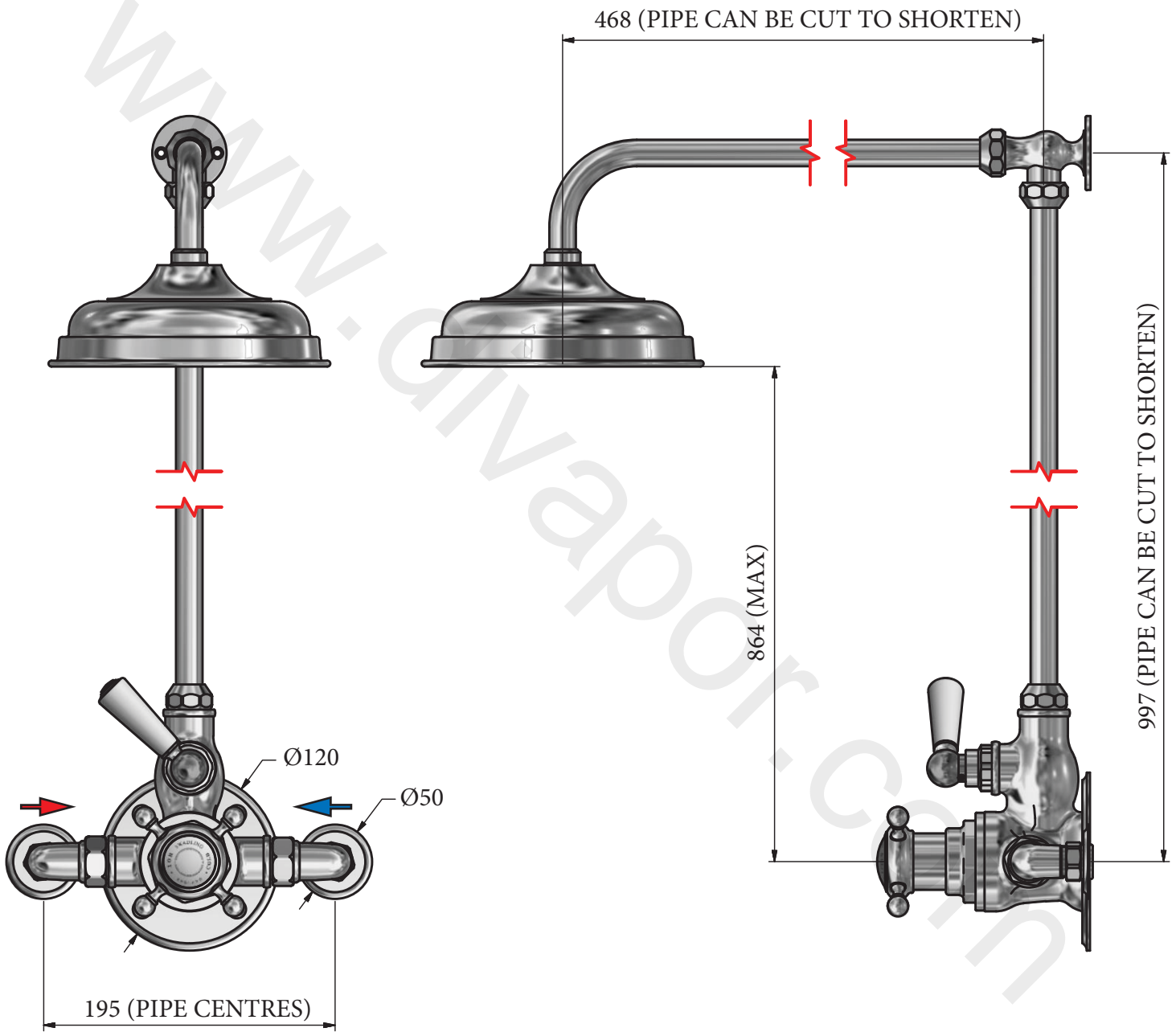

HOT AND COLD INLETS = 15mm COMPRESSION FITTINGS

PREPARATION

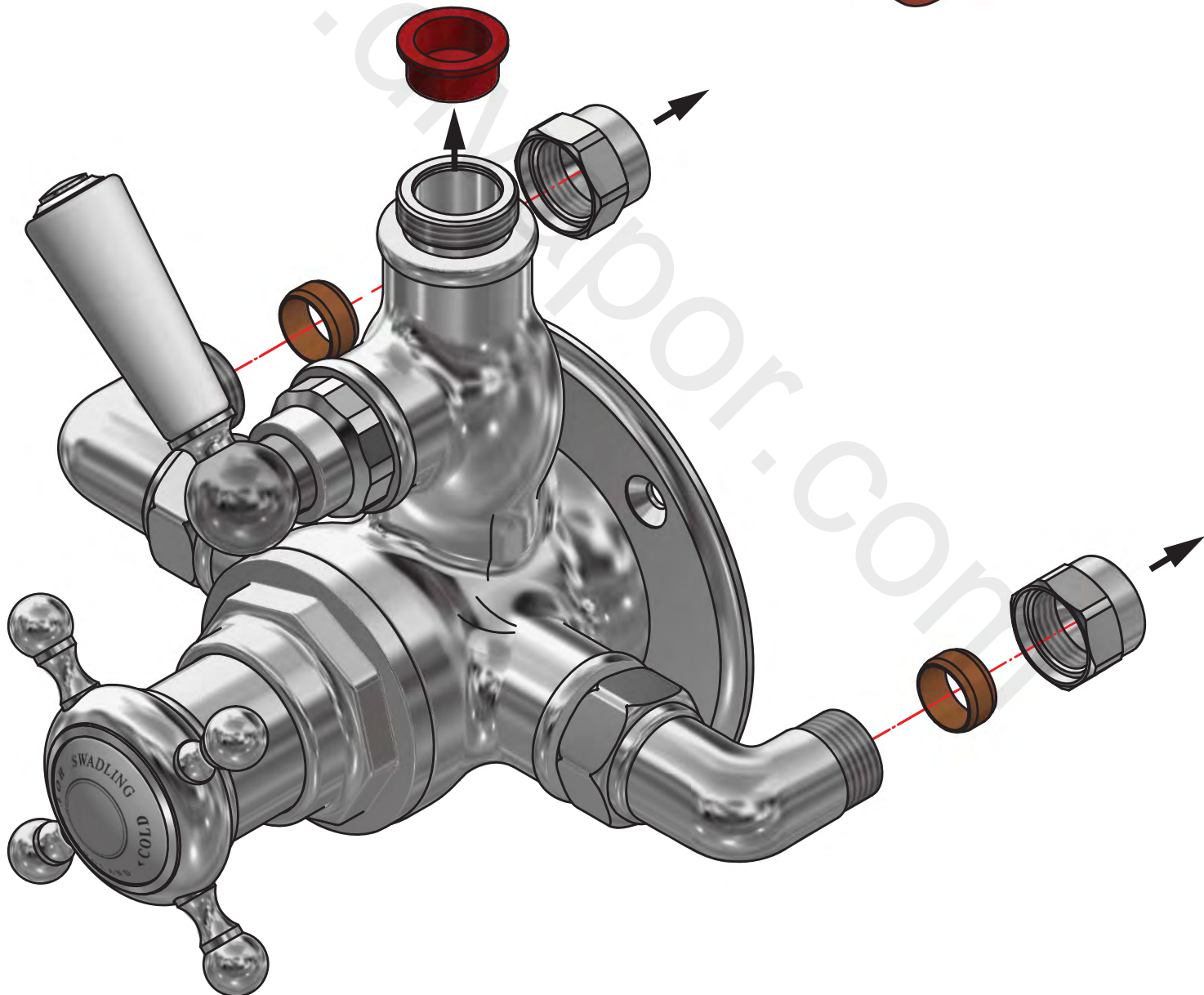
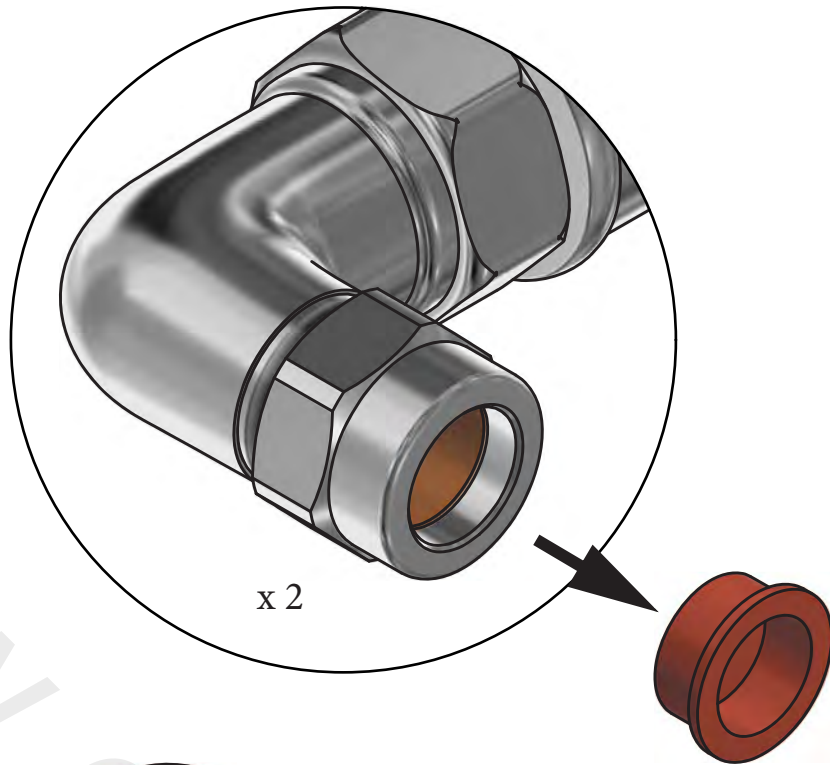

**MOUNTING & PLUMBING**

2

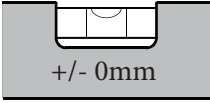

MIN 75 - MAX 105

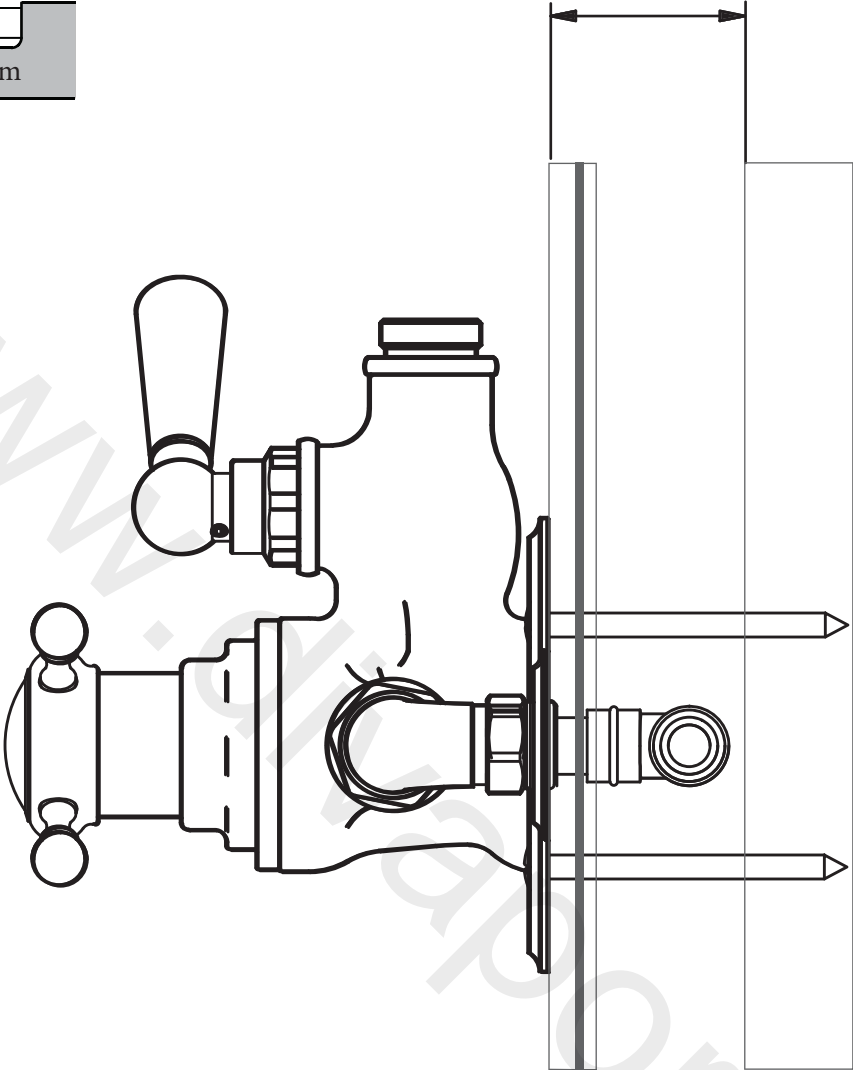

3

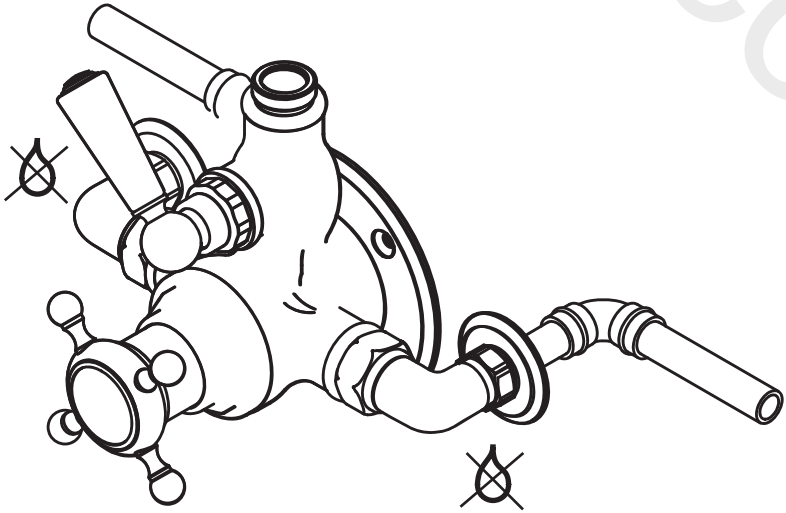

# TILING

Dry fit body first. Cut pipes to correct length, then silicon and screw to wall.

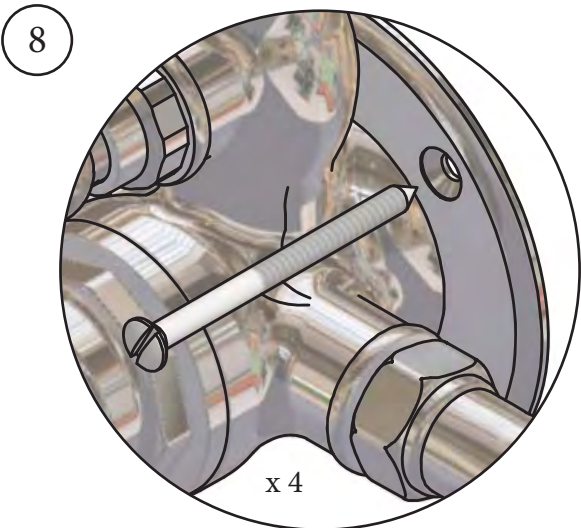
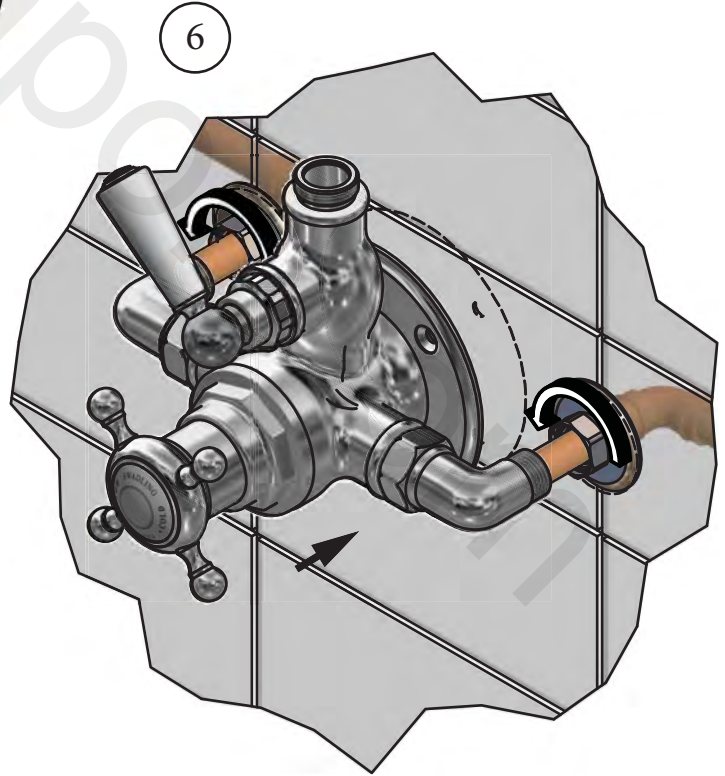
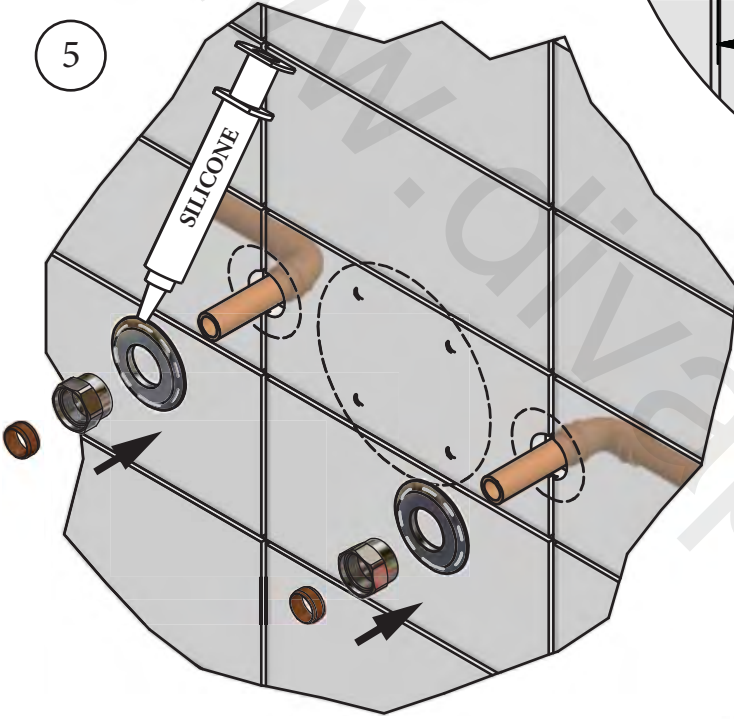
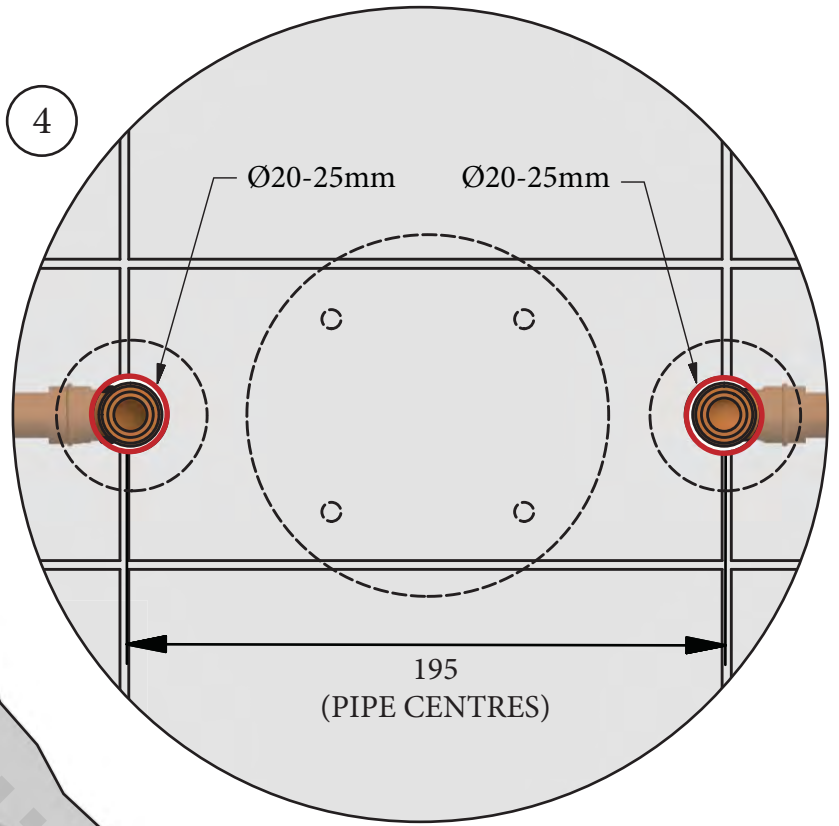

## SETTING THE TEMPERATURE

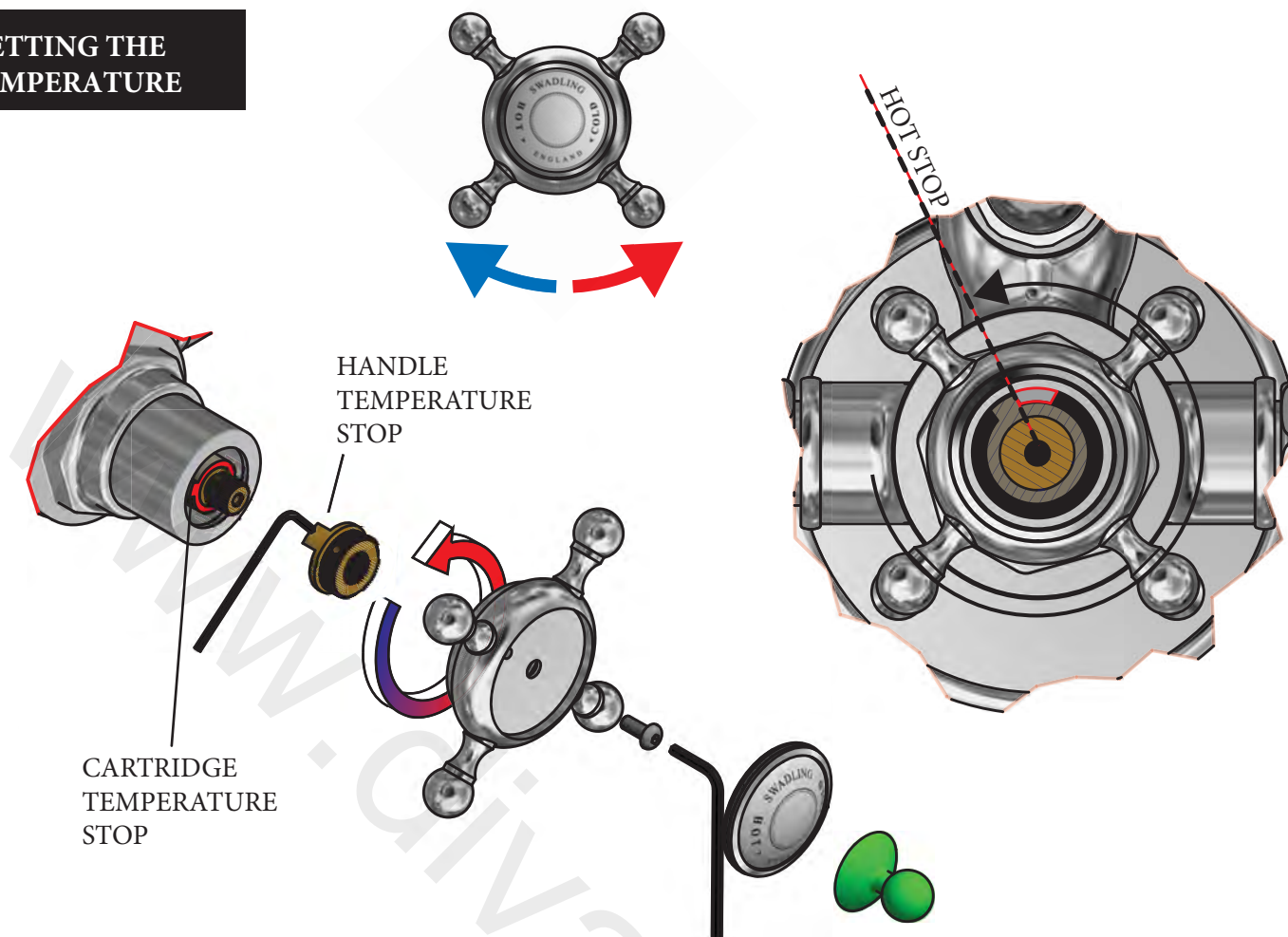

1. Assemble the Temperature handle to the Thermostatic cartridge.
  2. Using the handle rotate anti-clockwise until the Handle temperature stop meets the Cartridge temperature stop and will not turn anymore anti-clockwise. This is the maximum hot water temperature - **The maximum temperature should not exceed 41°C.**
  3. To adjust the maximum temperature - Remove handle, re-position the Handle temperature stop by rotating the handle, re-fit handle and turn to stop position, re-test.
- If using for a Bath filler see **IMPORTANT** page for advised maximum temperatures

### Commissioning notes for Thermostatic Mixing Valves, please check the following

- (a) The designation of the Thermostatic mixing valve matches the application
- (b) The supply pressures are within the valve operating range
- (c) The supply temperatures are within the valve operating range
- (c) Isolating valves are fitted

If all these conditions are met set the temperature as per installation instructions.

It is a requirement that all TMV2 approved valves shall be verified against the original set temperature results once a year. When commissioning/testing is due the following performance checks should be done.

Measure the mixed water temperature at the outlet. Carry out the cold water supply isolation test by isolating the cold water supply to the TMV, wait for five seconds if water is still flowing check that the temperature is below 46°C. If there is no significant change to the set outlet temperature ( $\pm 2^\circ\text{C}$  or less change from the original settings) and the fail-safe shut off is functioning, then the valve is working correctly and no further service work is required.

### Notes

If there is a residual flow during the commissioning or the annual verification (cold water supply isolation test) then this is acceptable providing the temperature of the water seeping from the valve is no more than  $2^\circ\text{C}$  above the designated maximum mixed water outlet temperature setting of the valve. Temperature should be taken at normal flow rate after allowing for the system to stabilise. The sensing part of the readings thermometer probe must be fully submerged in the water that is to be tested. Any TMV that has been adjusted or serviced must be re-commissioned and re-tested in accordance with the installation instructions. The installation of the thermostatic mixing valve must comply with the requirements of the Water Supply (Water Fittings) Regulations 1999.

## PARTS LIST

### ALTERNATIVE OPTION FOR REMOVING CERAMIC DISC

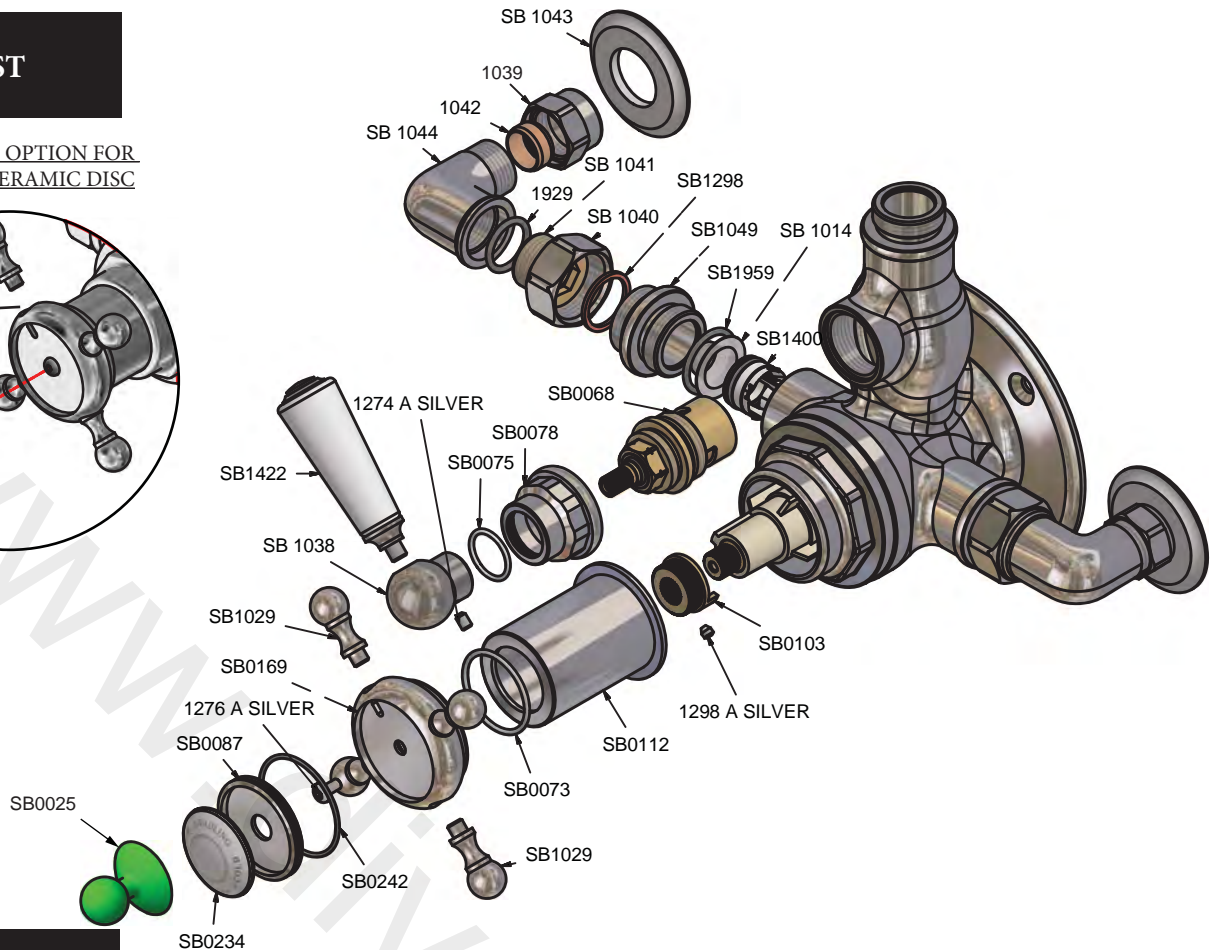
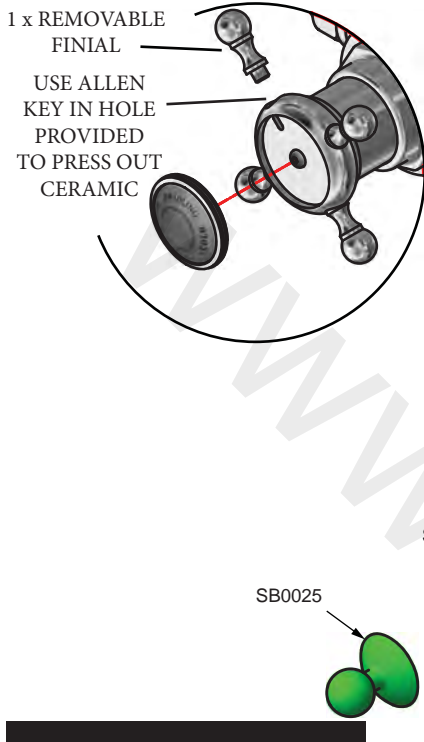

## TROUBLE SHOOTING

**IMPORTANT.** Before commencing maintenance on the shower isolate the hot and cold supplies. When maintenance is complete ensure the shower valve is checked and fully commissioned before use.

**1. Fault, After installation shower only runs Hot or Cold and will not mix.**

Hot & Cold supplies are plumbed the wrong way around. Remove the thermostatic cartridge, undo the 52mm AF clamp nut and pull the cartridge out (use the temperature knob to aid removal) reinstall the thermostatic cartridge with the lug pointing away from the hot and cold inlets. (See illustration above).

**2. Fault, Shower will not run hot enough when first installed.**

Maximum temperature needs adjusting, see SETTING THE TEMPERATURE

**3. Fault, Cold water tracking through the valve into the hot water system.** Check and clean the non return valve cartridges and gauze filters located under the non return valves.

**4. Fault, Shower will not run hot when first installed.** See SETTING THE TEMPERATURE. Check hot water supply from boiler is at specified temperature. See IMPORTANT.

**5. Fault, Shower only runs cold or lukewarm when first installed.** Thermostatic cartridge may have debris trapped in the cold side. Clean thermostatic cartridge.

**6. Fault, No flow or very low flow (gravity fed installations).** Very low pressure or blocked filters or pipe work.

**7. Fault, No flow or very low flow (pump fed installations).** Flow rate may be insufficient to activate booster pump flow switches, check pump requirements.

**8. Fault, Vibration or hammering.** Dynamic water pressure ratio between hot and cold inlets greater than 5:1 maximum. For optimum performance the inlet pressures should be balanced to within 10% of each other. Check for loose pipe work.