

RADA MX1 80NUK
INTELLIGENT CARE PANEL MOUNT TAP

- Non Touch IR flow control
- Brass valve engine (no plastics)
- Integral smooth bore copper outlet pipe
- Open bore flow insert, removable for easy cleaning
- High internal valve flow velocity
- Air tested at factory
- Programmable duty flushing / Thermal disinfection
- Integral 12 month data log
- Networkable using modbus RTU over RS485
- HTM04-01 Compliant



Specify as:

Rada MX1 80NUK (76676-CP)

Intelligent thermostatic panel mount tap with non-touch flow (IR) control, smooth bore copper outlet pipe with open bore flow insert, check valve/ filter unit, programmable temperatures, run time, automated blend duty flush and cold flush, thermal disinfection, integral 12 month data log and optional connection to building network systems.

Installation Diagram

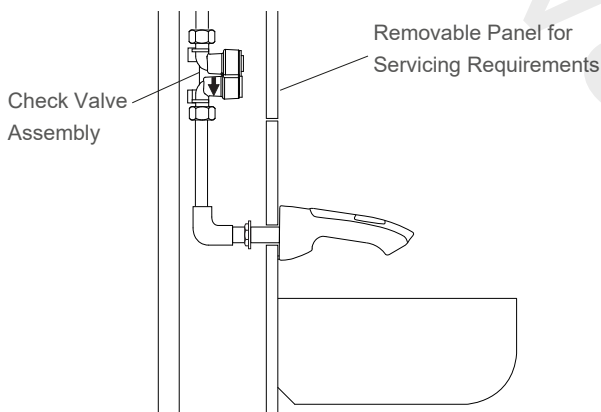

Dimensions (mm)

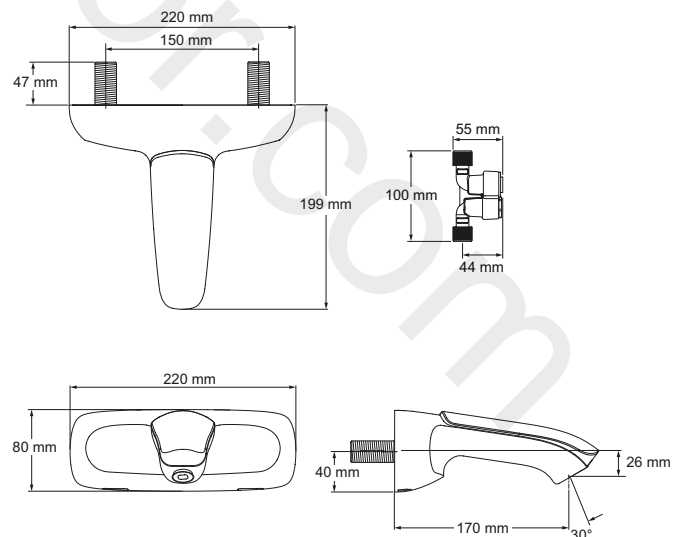

Flow Diagram

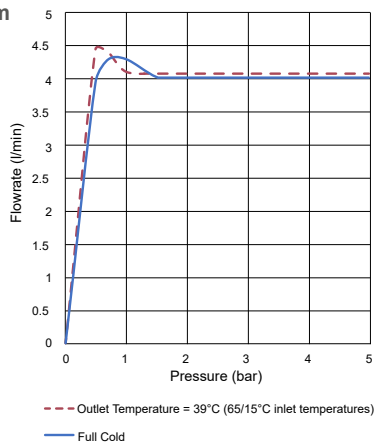

Kohler Mira Limited
Cromwell Road
Cheltenham
Gloucestershire
GL52 5EP

Specification Enquiries
Tel: 0344 571 1777 (Option 1)
Email: rada_technical@mirashowers.com
www.radacontrols.com



TECHNICAL SPECIFICATION

Operation

Flow: Infra red non-touch activation

Approvals

WRAS
 KIWA UK
 TMV3 (HP-WE)
 BEAB EN 60730-2-8
 EN 61558-2-16 (Power Supply)

Temperature

Factory pre-set: 39°C
 Programmable range - Min: 33°C Max: 45°C
 Note: Full cold can be selected during programming
 Maximum hot water: 55 - 65°C (80°C for thermal disinfection)
 Temperature check mode: Allows measurement of blend as well as hot and cold inlet supplies

Pressure Range

Note: Hot and cold supply pressures should be nominally equal.
 Maximum static pressure: 10 bar
 Minimum dynamic pressure: 1 bar
 Maximum dynamic pressure: 5 bar

Connections

15 mm Compression or 1/2" BSP
 Checkvalve / filter / flow regulator assembly with integral isolation:
 1/2" BSP / 15 mm compression

Flow

Modes: On/Off (Timed, Blocking)
 Flow Duration: Programmable (1 sec - 60 mins)

Electrical Specification

Power supply unit is supplied
 Power supply output: Rated voltage: 12 Vdc
 Rated current: 2.5 A
 Power supply input: Rated voltage: 100 Vac - 240 Vac
 Rated current: 1.0 A
 Frequency: 50/60 Hz

IP Ratings

Tap: IP X4
 Power supply unit: IP X4

Programming Options

Programming via Rada App using iOS tablet over Bluetooth
 Blend Duty Flushing:
 Operating modes: Off, Standard, Smart
 Activation time: Real time scheduling (hrs/mins)
 Interval period: 1hr - 1 Week
 Flush duration: 1 sec - 25 mins
 Set temperature: Programmable

Cold Only Flushing:
 Activation time: Real time scheduling (hrs/mins)
 Interval period: 1hr - 1 Week
 Flush duration: 5 sec - 10 mins

Thermal Disinfection:
 Operating modes: Off, Standard, Exponential
 Flush duration: 1- 30 mins
 Minimum temperature: Programmable

Networking

The MX1 Taps are networkable using modbus RTU over an RS485 connection.
 This enables the MX1 Taps to be linked to a Building Management System (Refer to separate IC Networking Datasheet - P6480).

Accessory

Part no. 76705-NA: Rada (ACI 9) 2.5m extension cable
 Part no. 1.1664.234.1: Pall Filter Adaptor

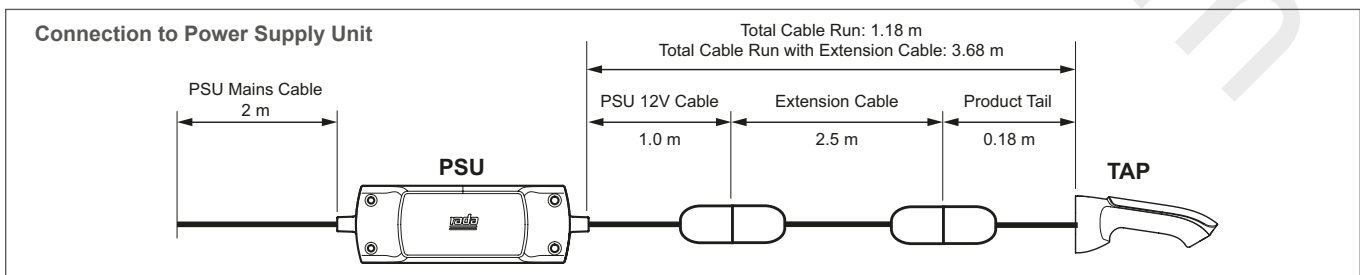

Kohler Mira Limited
 Cromwell Road, Cheltenham
 Gloucestershire, GL52 5EP

Specification Enquiries
 Tel: 0344 571 1777 (Option 1)
 Email: rada_technical@mirashowers.com
 www.radacontrols.com

Rada is a registered trademark of Kohler Mira Limited.
 The company reserves the right to alter product specification without notice.
 © September 2019 Kohler Mira Limited. All rights reserved.
 No part of this document, or any accompanying document, may be reproduced or transmitted in any form or by any means, including photocopying or electronically, without the permission of Kohler Mira Limited.

A KOHLER COMPANY

