

Regal basin mixer no waste tap

nabis

Product code – A05433

The nabis Regal range boasts a traditional design that appeals to classic taste.



Features:

- 1/4 turn 1/2" head valve
- Chrome finish
- Brass tap body
- Zinc handle
- Neopearl aerator
- Minimum working pressure: 0.3 bar
- Operation pressure range: 0.3 bar – 5 bar
- Suitable for both low & high-pressure systems

Flow rates			
Pressure (Bar)	Hot water only (L/m)	Cold water only (L/m)	Mix (L/m)
0.1	3.2	3.0	3.5
0.2	4.1	4.2	4.7
0.3	5.2	5.1	5.6
0.4	6.1	6.2	6.5
0.5	7.2	7.0	7.1
1	9.0	9.2	10.0
2	13.0	13.1	14.1
3	16.1	16.0	17.2
4	19.0	19.2	19.8
5	21.0	21.1	22.1

Product dimension and weight	
Product dimension (mm)	170x115x116
Net weight (kg)	0.750
Gross weight (kg)	1.200



Plumbing

Heating

Cooling

Drainage

Pipe

Parts

WOLSELEY



The Specialist Merchant

Details

Item	Description	Qty	Material	Spec
1	Cap Nut	2	Hpb59-1	M24X1
2	Indice	2	Ceramics	-
3	Connector	2	Hpb59-1	M24X1
4	Screw	2	Stainless Steel 304	M4X10
5	Handle	2	Zinc	-
6	Rosette	2	Zinc	-
7	Head Valve	2	Assembly	G1/2"
8	Body	1	Hpb59-1	-
9	'O' Ring	1	Rubber	Ø43XØ2.5
10	Fixing Bar	1	Iron	M8
11	Rubber Washer	1	Rubber	M8
12	Iron Washer	1	Iron	M8
13	Nut	1	Brass	M8
14	Flexible Hose	2	Stainless Steel 304	XXXXXXX
15	Aerator	1	Assembly	M24X1

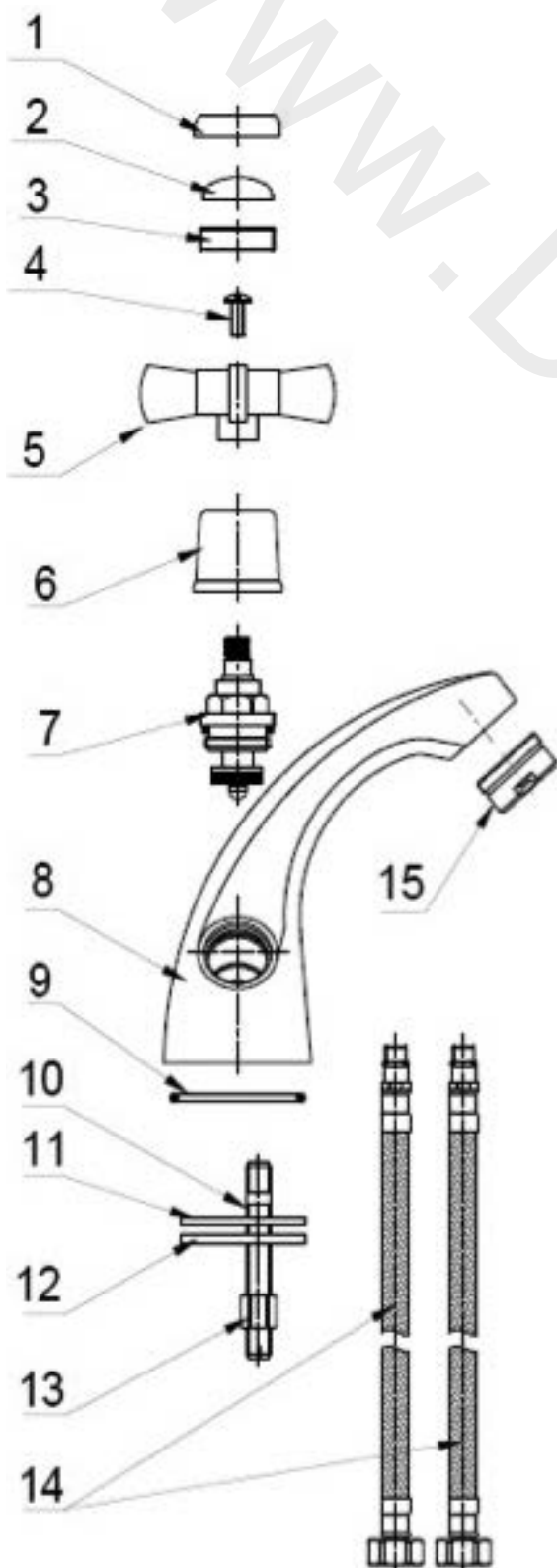

wolseley.co.uk

The information contained on this page was correct at date of issue. Fitting dimensions are provided as a guide only. Some variation may occur due to manufacturing tolerances. We pursue a policy of continuing improvement in design and performance of products and so reserve the right to change specifications without prior notice.

Version number 1.0



wolseley.co.uk