

Armitage Shanks

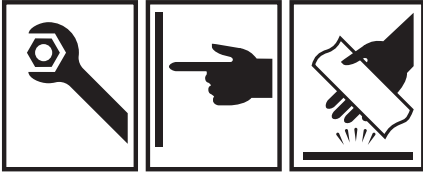

Lever operated sequential thermostatic
monobloc mixers taps

**INSTALLATION
INSTRUCTIONS**



AUTHORISED
USER NO. 00865
Applies to
A4131AA only

**CONTOUR 21: A4131AA, A4169AA
& A6430AA.
NUASTYLE: S7449AA**

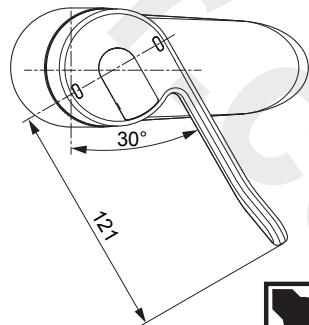
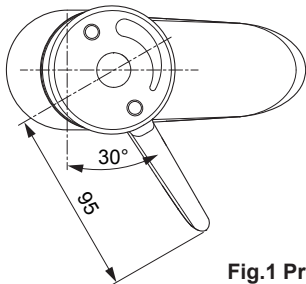
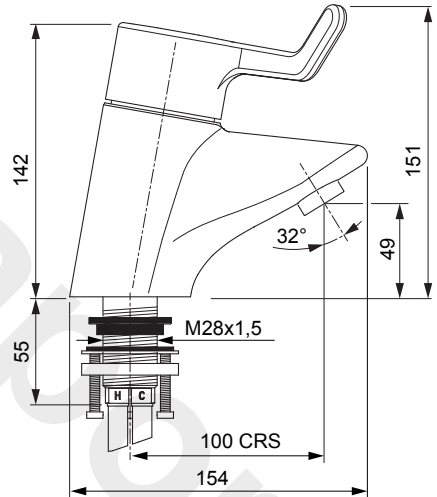
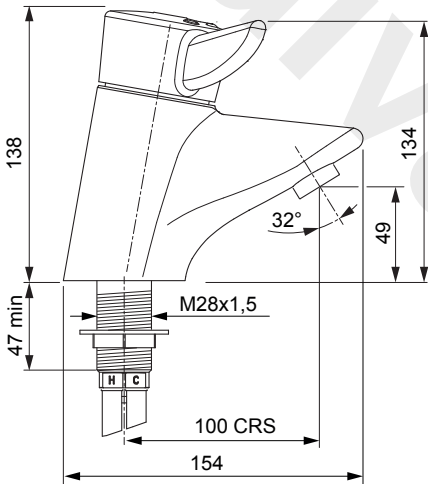

Fig.1 Product dimensions

INSTALLER: After installation please pass this instruction booklet to user



TABLE OF CONTENT

2	DESCRIPTION.....	3
3	DIMENSIONS	3
4	WATER SUPPLY CONDITIONS	3
4.1	INTRODUCTION	3
4.2	SUPPLY PRESSURE REQUIREMENTS	3
4.3	HEALTHCARE ESTABLISHMENTS	4
5	INSTALLATION	5
6	OPERATION	6
7	COMMISSIONING AND AUDITS	6
7.1	PURPOSE OF COMMISSIONING	6
7.2	COMMISSIONING PROCESS	7
7.3	AUDIT CHECKS ON TMV'S	8
7.4	AUDIT PROCEDURE	9
7.5	IN-FIELD 'COLD WATER ISOLATION'(CWI) TEST.....	9
8	SERVICING - TVM3 SCHEME	10
8.1	FREQUENCY OF REGULAR SERVICING	10
9	MAINTENANCE	11
9.1	ADJUSTMENT OF THE MIX TEMPERATURE	11
9.2	REMOVAL AND INSPECTION OF CARTRIDGE	11
9.3	IMPORTANT NOTES ON DEBRIS	12
9.4	THERMOSTATIC CARTRIDGE AGEING	12
9.5	MAINTENANCE CLEANING	12
10	SERVICE VALVES	13
11	SPARE PARTS.....	14
12	SPARE PARTS LIST	15
13	CLEANING CHROME SURFACES	16

The fittings covered by this installation and maintenance instruction should be installed in accordance with the Water Regulations published in 1999*, therefore Armitage Shanks would strongly recommends that these fittings are installed by a professional installer.

*A guide to the Water Supply (Water Fittings) Regulations 1999 and the Water Byelaws 2000, Scotland is published by WRAS (Water Regulations Advisory Scheme) Fern Close, Pen-y-Fan Industrial Estate, Oakdale, Newport, NP11 3EH. ISBN 0-9539708-0-9

2 DESCRIPTION

A4131AA	Contour 21 sequential lever operated thermostatic monobloc mixer tap flexible tails
A4169AA	Contour 21 sequential lever operated thermostatic monobloc mixer tap copper tails
A6430AA	Contour 21 sequential lever operated thermostatic monobloc mixer with Armitage Bioguard outlet & copper inlet tails
S7449AA	Nuastyle sequential lever operated thermostatic monobloc mixer flexible tails

This manual covers the A4131AA, A4169AA, A6430AA & S7449AA thermostatically controlled, lever operated, sequential mixing taps. They are designed to provide water from ambient cold up to a safe maximum temperature for hand washing.

These products are intended to be installed on single hole or two taphole washbasins with a tap hole size of 30 to 36mm.

The product comes complete with flexible inlet tails or alternatively rigid copper inlet tails, isolation valves with strainers, check valves and flow regulators.

Avoid using heat for soldering near the mixer inlets, to prevent damage to internal components.

3 DIMENSIONS

Product dimensions are shown on front page, see Fig.1.

4 WATER SUPPLY CONDITIONS

4.1 Introduction

This sequential thermostatic lever operated mixer is manufactured to the highest standards and has approval to TMV3 which permits it to be installed in healthcare establishments such as hospitals, nursing homes and residential care homes. When installed in healthcare establishments the supply conditions detailed in Table 1 must be observed and the commissioning and servicing requirements detailed on section 7 & 8 must be followed.

For other installations this is not a requirement.

4.2 Supply Pressure Requirements









This mixer is designed to be installed on all types of plumbing systems.

Hot and cold water supply pressures should be reasonably balanced, however, the mixer will function within specification on unequal pressures up to 5 :1.

The fitting should be installed as permit the operation of isolation valves and give access for servicing the strainer elements.

The minimum pressure for the correct operation is 0.2 bar. For supply pressures less than 0.4 bar it may be necessary to remove the flow regulators elements. See figure 12, Sect.10.

Table 2 shows the flow rate performance of the flow straightener and flow regulators outlets

Q (3,0 bar)		6,8 l/min Ref 7D	
Q (3,0 bar)		4,7 l/min Ref 7C (fitted)	
Q (3,0 bar)		1,8 l/min Ref 7E	
Q (3,0 bar)		6,8 l/min Ref 7B	

**Table 2: Flow rate data
(Q=flow rate)**

Note:

A4131AA - Fitted outlet is Water Technology Listed approved flow regulator. Unregulated flow straightener is separately supplied.

When using 7B or 7D flow rate is determined by the regulators fitted in the service valves: Delivering at least 6.8 l/min.



Optional Bioguard Outlet (Except A6430AA)

It has been established that certain designs of outlet devices harbour planktonic bacteria, thereby encouraging the development of bio film & the bacteria colonisation process.

This new Armitage Bioguard outlet replaces the traditional flow straightener with a fully open copper-lined waterway. This greatly reduces the risk of bacteria build-up, whilst the copper lining has natural anti-microbial properties.

With the exception of A6430AA, Contour 21 & Nuastyle basin mixers from Armitage Shanks are factory fitted with an M24 anti-vandal outlet. These can be removed with a special outlet key & replaced with our retrofit Armitage Bioguard Outlet.

See section 11 for spares code (supplied in packs of 10).

4.3 Healthcare Establishments

In accordance with the NHS model engineering specifications DO8 this valve has approval for the following applications:-

High Pressure	HP-	-WE
Low Pressure	LP-	-WE

For this type of application the following supply conditions must apply:

Operating pressure range:	High Pressure	Low Pressure
Maximum static pressure	10 bar	10 bar
Flow pressure hot and cold	1 to 5.0 bar	0.2 to 1.0 bar
Hot supply temperature	55 to 65 °C	55 to 65 °C
Cold supply temperature	5 to 20 °C	5 to 20 °C

Note:

Fittings operating outside these conditions cannot be guaranteed by the scheme to operate as **TMV3**.

← *52°C absolute minimum can be used but not recommended

Table 1 Supply conditions for healthcare establishments

Effectively this means:

Differential between HOT and COLD inlet temperatures (Δt) must be 32°C min and 60°C max

Differential between HOT inlet temperature and MIXED temperature (Δt) must be 11°C absolute minimum but > 14°C preferred

See 7.3 Audit checks on TMV's.

5 INSTALLATION

FIXATION

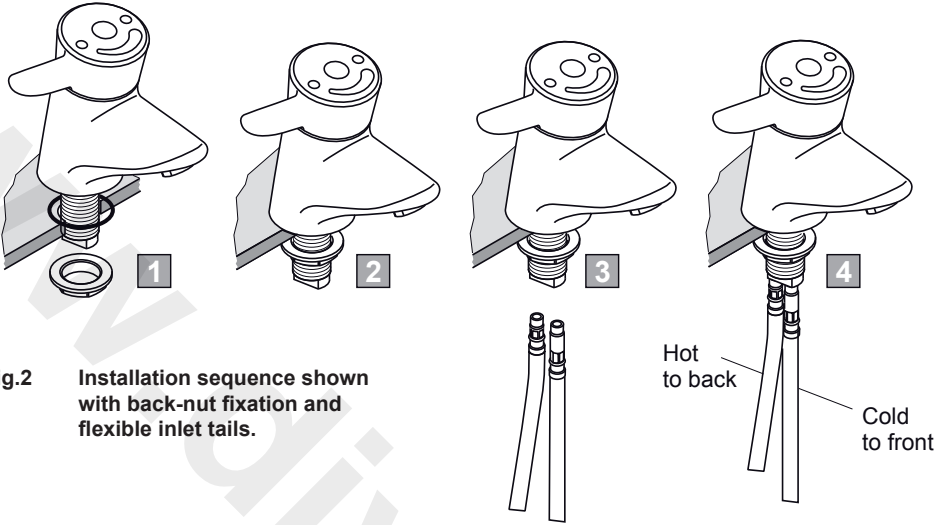

Fig.2 Installation sequence shown with back-nut fixation and flexible inlet tails.

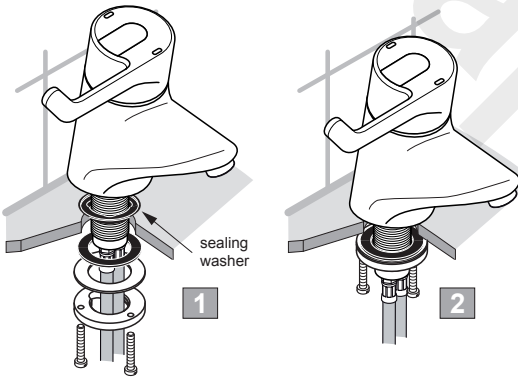

Fig.3 Installation sequence shown with clamping ring fixation

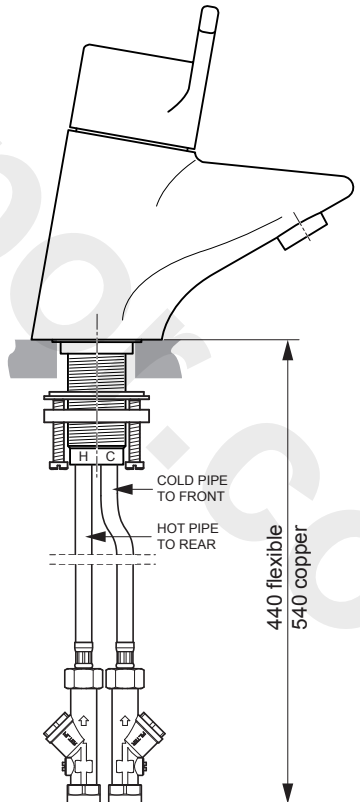

Fig.4 Inlet tail lengths

Note: Product may have clamping ring or back-nut type fixation.

- Insert the fitting into the tap hole ensuring that the seal is correctly seated in the groove on the underside of the fitting body.
- Screw on the backnut and tighten or alternatively:
Fit the clamping assembly to the tail and tighten the three screws till the fitting is secure.
- Screw in the flexible inlet tails (short thread extension first) - (For the rigid copper tail version the tails may be fitted before inserting into the tap hole and the tails may be fitted in any order)
- Fit the isolating valves to the flexible tails
- Connect the isolating valves to the supplies.
- Ensure all joints are tight and check for leaks.

IMPORTANT NOTE:

Before connecting the product, it is strongly recommended to flush the supply pipe-work to remove any residues or debris remaining after installation

6 OPERATION

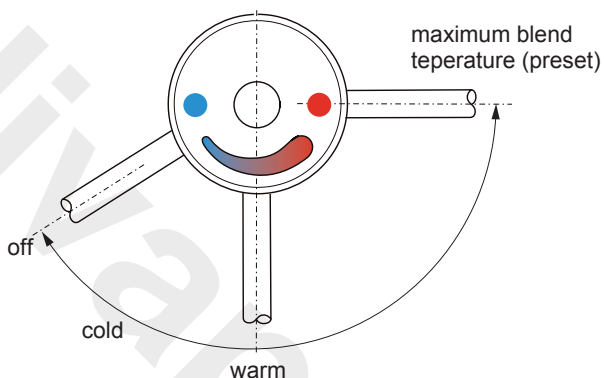

Fig.5 Showing the handle control positions. As the handle is rotated anti-clockwise from the off position the delivered water progresses from cold through warm to the preset maximum temperature of approximately 41°C

When installed as a TMV3 application it is requirement that the commissioning and maintenance procedures detailed here be carried out.

For non healthcare installations these checks are not requirements.

7 COMMISSIONING AND AUDITS

The following procedure should be conducted after installation to ensure the product is functioning correctly.

7.1 Purpose of commissioning

- To confirm the correct designation of product versus application.
- To confirm the correct supply water conditions for the product / installation.
- To adjust the mixed temperature if necessary to suit the water supply conditions of the installation.
- To check the product is performing properly.
- To start an audit log and record appropriate data.

This product is factory set at $40\pm 1^{\circ}\text{C}$ with supplies of circa; 3 bar balanced pressure and temperatures of 15°C cold & 65°C hot (i.e. an inlet Δt of 50°C & a hot / mix Δt of 24°C)

For supply requirements, see 4.0 Water Supply Conditions.

7.2 Commissioning Process (see decision tree FC1)

- Establish that the supply conditions are within the requirements outlined above. If not investigate.
- When conditions are acceptable record them, together with hot and cold temperatures. Establish Δt .

Check the outlet mix temperature is within $41^{\circ}\text{C} \pm 2^{\circ}\text{C}$, if not (probably due to $\Delta t > 5^{\circ}\text{C}$ difference to factory setting) adjust appropriately. (see 9.1)

- If mixed temperature is correct undertake an 'in field' cold water isolation (CWI) test: (see 7.5)

Pass – restore supply and record mixed temperature,

Fail – See 7.5 in-field 'Cold Water Isolation' test.

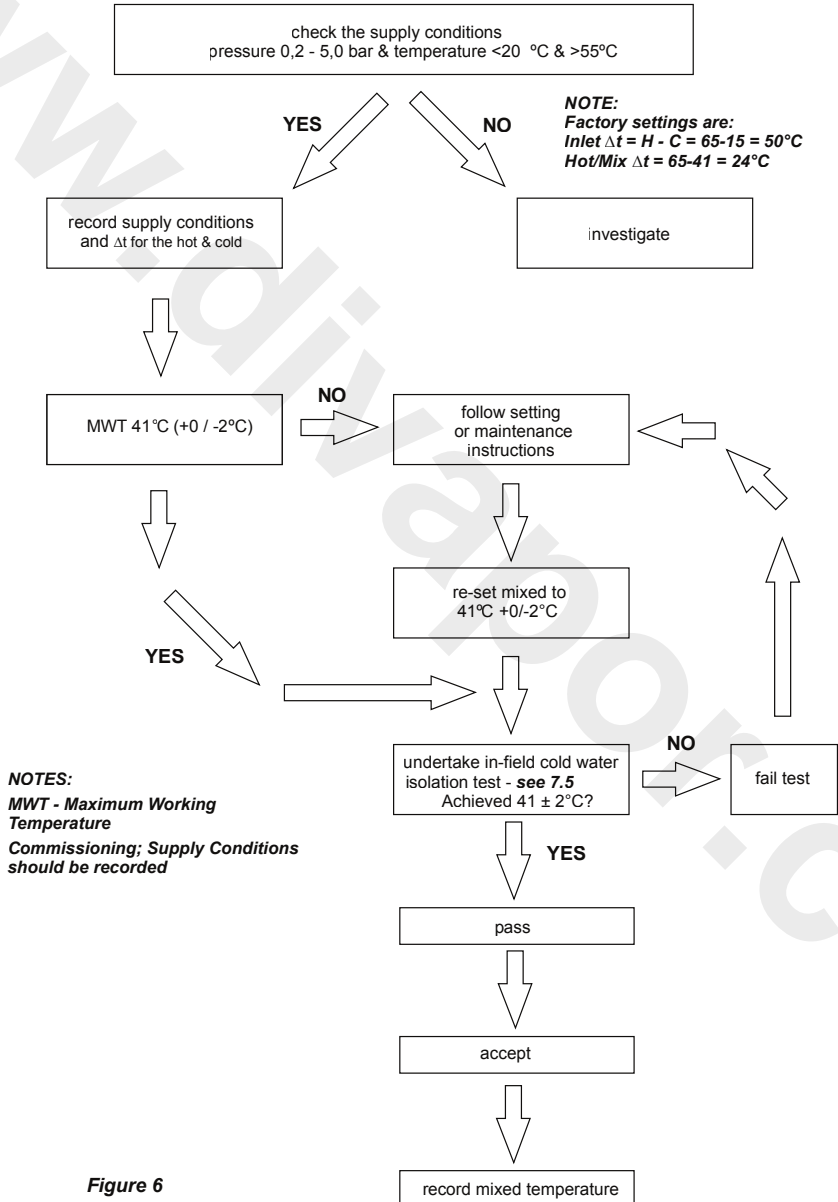

Figure 6

7.3 Audit Checks on TMV's

The purpose of a performance audit of a product is:

- ♦ To check the product continues to perform properly.
- ♦ To flag the need for the product to be adjusted due to supply condition changes or mechanism ageing.
- ♦ To ultimately identify the need for product maintenance.

Note - Additionally these audits facilitate regular verification of the supply conditions in accordance with section 4.3 requirements. (See decision tree FC3)

Audit of Supplies To Fittings (FC3)

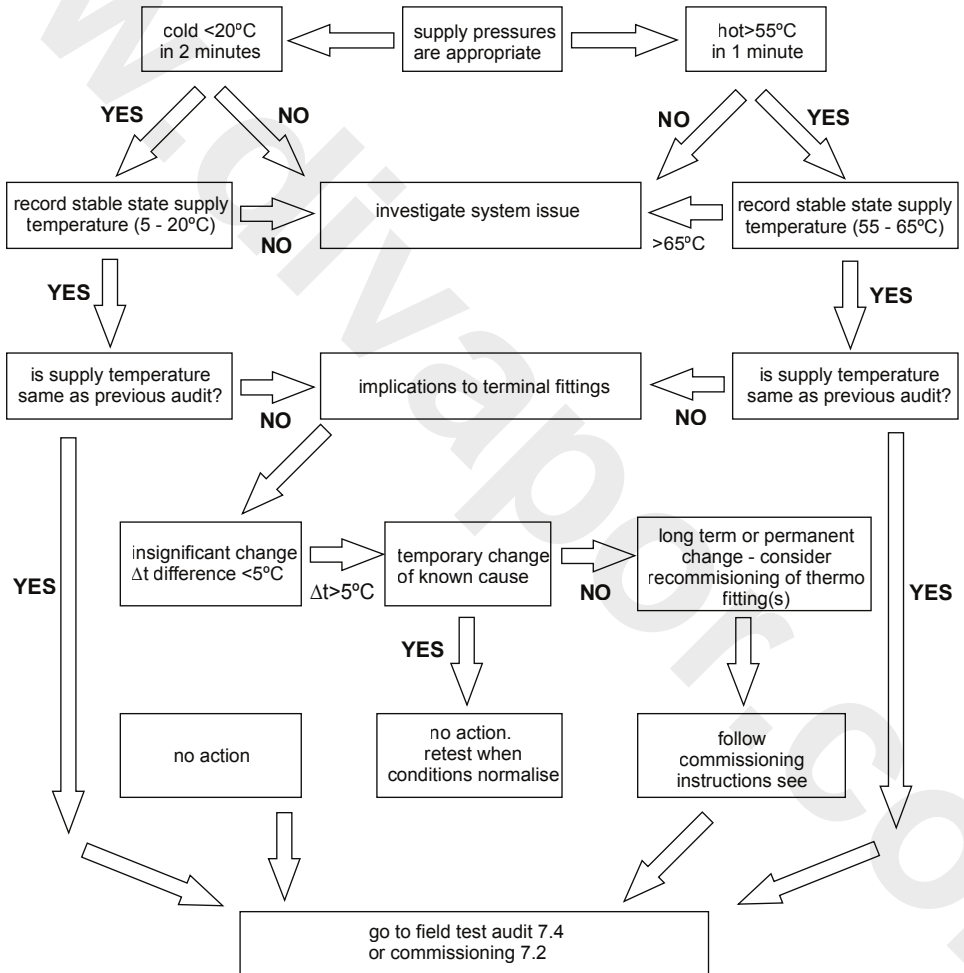

Figure 7

7.4 Audit procedure (see decision tree FC2)

- Verify the water supplies conditions are similar to when the product was commissioned i.e. inlet Δt as previous + / - 5°C

Note: If inlet Δt change is $> 5^{\circ}\text{C}$ consider the cause of the change. If it is seen as a long term or permanent change, re-commission the product. If however, it is only a temporary change, retest when normal conditions resume.

- If inlet Δt differs from the commissioning Δt by $< 5^{\circ}\text{C}$ carry out field 'cold water isolation' (CWI) test as D-08:2009. (see 7.5 in field **Cold Water Isolation test failure**).
- Pass - restore the cold supply and move on to check the mix temperature.

Note: If the product fails CWI test, refer to 7.5 and then re-commission the valve.

- Mixed Temperature is as commissioned $\pm 2^{\circ}\text{C}$, Accept and record the temperature.

Note: If mixed Deviation $> \pm 2^{\circ}\text{C}$ (1st instance) reset mix as instructions and redo the test from start. See 9.1 Adjustment of the mix temperature.

- 2nd & subsequent instances follow maintenance instructions.

7.5 In-field 'Cold Water Isolation' (CWI) test.

Using a flat-blade screw driver, the screw can be rotated 90° anti-clockwise to isolate the cold water supply.

Before commencing the CWI test, ensure:

- The water supply conditions are met either:
 - For commissioning a new product (see table 1, section 4).
 - Or the inlet Δt is within $\pm 5^{\circ}\text{C}$ to when the product was commissioned (see 7.4).

NOTE It is important that the hot temperature is greater than 55°C

- Mixed water outlet temperature is correct (see table 2, section 8).

Fitting Field Test Audit (FC2)

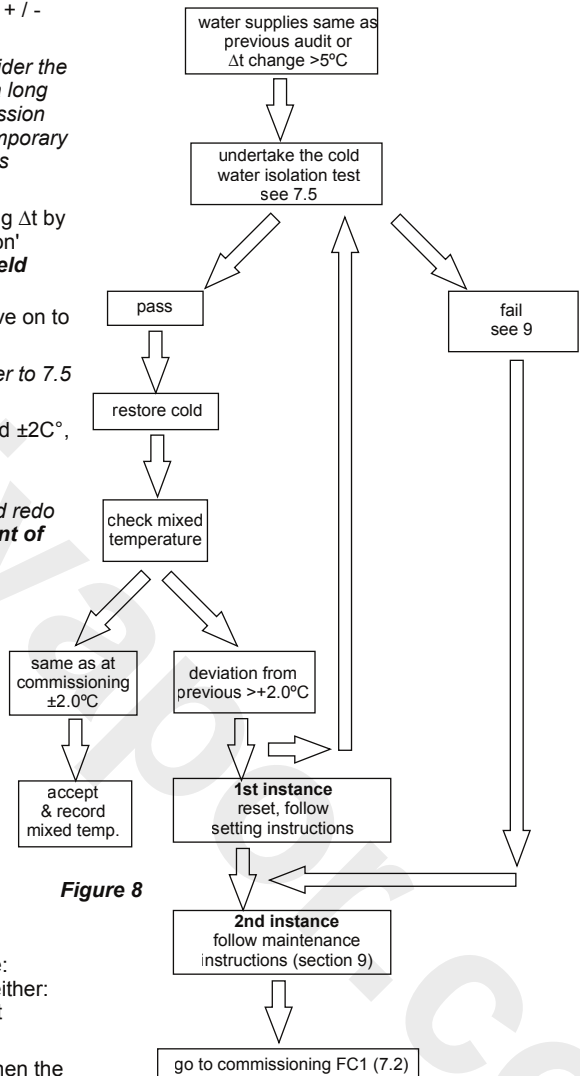

Figure 8

To perform a CWI test, operate the product by rotating the lever fully to the right.

Then conduct the following procedure:

1. Record the steady state temperature of both hot and cold water supplies. Note the Δt .
2. Record the temperature of the mixed water at the outlet.
3. Isolate the cold water supply (by rotating the isolating screw 90° & monitor the flow of water from the outlet).

If the flow ceases, CWI test passed:

1. Restore the cold water supply by rotating the isolator screw 90° clockwise.
2. Re-check the temperature of the stabilised mixed water at the outlet to ensure it is still correct.

Accept & record mixed temperature.

If there is an ongoing flow of water from the mixed water outlet, then 5 seconds after CWI collect the discharging water into a measuring vessel for 60 seconds. To pass the CWI test the volume of collected water should be less than 120ml.

If the product fails CWI test, see FC2 (see section 7.4). Follow product maintenance (see section 9) and servicing (see section 8) instructions.

8 SERVICING - TVM3 SCHEME

The need for servicing is normally identified as a result of the regular performance auditing.

Application	Maximum mixed water temperature during normal operation	Permitted maximum stabilised temperature recorded during site testing – excluding transient spikes
Washbasin	41°C	43°C

Table 2 A guide to maximum temperature sets

8.1 FREQUENCY OF REGULAR SERVICING

The purpose of servicing regularly is to monitor any changes in performance due to changes in either the system or the product. This may highlight the need to adjust either the supply system or the product. These products should be audited 6 to 8 weeks and again 12 to 15 weeks after commissioning. The results are to be compared against original commissioning settings.

If there are no significant changes at the mixed temperature outlet then a 6 monthly servicing cycle may be adopted. Otherwise, servicing checks should be carried out more frequently (e.g. every 4 months).

Follow the recommended auditing and maintenance procedures detailed in sections 7 & 9.

During servicing, note the following:

1. Repeat the procedure of recording and checking supply temperatures. (The same type of measuring equipment should be used)
2. If the temperature has changed significantly from the previously recorded valves, the following should be checked:
 - a. All in-line or integral valve filters are clear of obstruction.
 - b. All in-line or integral check valves are clean and working properly to prevent backflow.
 - c. Any isolating valves are fully open.
 - d. The thermostat is free of debris
3. When satisfied with the mixed outlet temperatures re-record the temperatures.

9 MAINTENANCE

When installed in a TMV3 application, we recommend that the commissioning and maintenance procedures, detailed under 7 & 8, be carried out.

9.1 Adjustment of the mix temperature

♦ **Note: Cartridge is factory pre-set at $40\pm 1^{\circ}\text{C}$.**

1. Move the lever to the fully on (max) position.
2. Remove the lever by prising out the cover button and unscrewing the retaining screw using a 4mm Allen key.
3. Remove the upper Anti clockwise stop ring (slide off spindle).
4. Rotate spindle (using lever handle) to achieve correct mix temperature. ($40\pm 1^{\circ}\text{C}$) Rotate clockwise to reduce and anti-clockwise to increase
5. Refit the upper stop ring against cartridge stop face.

Note:1. This is the normal maximum temperature range for the product and as such there is a wide zone of spindle movement that gives this mix temperature. For best performance you should refit the stop at the first point of anticlockwise rotation that achieves the desired setting.

Note:2. If you are unable to achieve $40\pm 1^{\circ}\text{C}$ Max and you have the correct Δt 's it may be due to fine debris. See 9.2 Removal and inspection of cartridge.

6. Upon successful completion of the temperature adjustment, conduct the **Cold Water Isolation (CWI) test (See 7.5)** to ensure product is working properly.
7. Refit the lever and record the mix temperature.

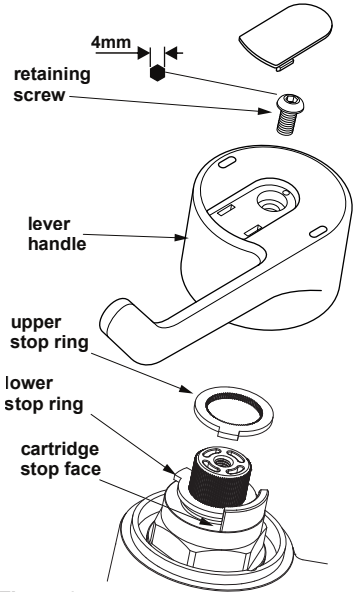

Figure 9
Adjusting the pre-set temperature

9.2 Removal and inspection of cartridge

After checking that supply conditions are within the specified parameters (see table 1), if the fitting malfunctions or should the test results fail to fall within the specified limits consider replacing the cartridge with a new one. **See 9.3 Important notes on debris.**

Isolate the fitting by turning the isolating valves 90° anti-clockwise (viewed facing the iso-valve).

Remove the lever handle as described in 9.1. Unscrew the cartridge from the body with a 36mm a/f deep socket. Inspect cartridge for damage.

Replace cartridge if necessary and reassemble cartridge into body.

The replacement cartridge should be tightened to a torque of 15Nm. (To re-secure the cartridge we recommend the use of Permabond A011 or equivalent applied to the thread of the cartridge)

Replace lever handle and reinstate the supplies.

After fitting the new cartridge start the test procedure from the section on commissioning.

- ♦ Redo the Cold Water Isolation (CWI) test (**See 7.5**).
- ♦ Once satisfied with the CWI test, re-check and if necessary, adjust the maximum mix temperature, see (**See 9.1**).
- ♦ Record the mix temperature.

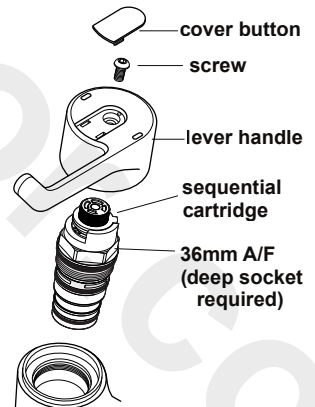

Figure 10
Exploded view showing sequential cartridge

9.3 Important notes on debris

Although this product is protected by the service valve filters, debris can still find its way to the thermostat housing area. This can happen during servicing for example. Remove cartridge (see section 9.2) and carry out an inspection.

9.4 Thermostatic Cartridge Ageing

Following many years of normal service you may notice the following:

1. The need to carry out more frequent adjustment of mixed temperature.
2. The thermostatic element may not pass the CWI test.

These issues could be due to the ageing of the thermostat which loses some expansion capability over time.

These are the principle objectives of testing, as they serve to indicate to maintenance staff the declining performance capability of the thermostatic cartridge.

For this reason the audit testing flow chart highlights that 2nd Instance CWI test failure or 2nd instance mixed deviation even with stable 'as commissioned' supply conditions and correct inlet supply Δ 's, is potentially the first indication of the need to replace the cartridge.

9.5 Maintenance cleaning

On a regular basis the anti-splash nozzle should be inspected and cleaned if necessary. This should be done immediately before sterilising is carried out.

In areas where lime scale build-up is prevalent this will have to be removed. An inhibited proprietary scale solvent can be used such a kettle descaling solvent but it is important to follow the manufacturer's guidelines. After descaling it is important to rinse the parts thoroughly in clean water. Clean carefully and do not use abrasive materials or scrapers

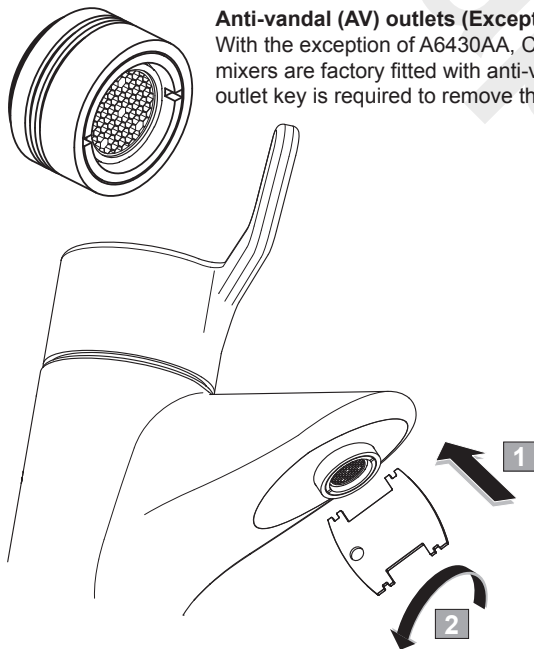

Anti-vandal (AV) outlets (Except A6430AA)

With the exception of A6430AA, Contour 21 & Nuastyle basin mixers are factory fitted with anti-vandal outlets. A special outlet key is required to remove these outlets from the mixer.

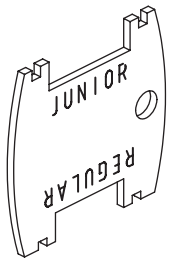

To remove the AV outlet, use this special outlet key (supplied) to unscrew the AV housing.

Using the side of the key marked "junior" locate the key into the slots in the inner ring of the housing and unscrew (anti-clockwise).

Remove the AV housing complete with flow straightener & seal.

Fitting the optional Armitage Bioguard Outlet (Except A6430AA)

The Armitage Bioguard Outlet (threaded M24x1 externally) can be fitted directly into the mixer outlet without a rubber seal (i.e.: metal to metal).

Simply screw the Armitage Bioguard outlet clockwise by hand into the mixer outlet.

Finally tighten gently using a 22mm A/F spanner on the flats until the outlet has bottomed in the bore. Take care not to over tighten.

Important – no seal required

This Armitage Bioguard Outlet has been designed with an open bore, which means there is very little back pressure in the spout chamber. Consequently the traditional rubber seal (washer) has been eliminated. A seal has not been provided & should not be necessary as a sound metal to metal joint is possible.

Patent pending for Armitage Bioguard antibacterial outlet, application

No: 10 2012 107 243.4

10 SERVICE VALVES

The service valves contain filter, check, isolating valve & 4lpm regulator

Isolation valves facilitate 4 activities:

- 1) Cleaning strainers & check valves
- 2) Servicing the cartridge
- 3) Disinfection
- 4) Audit cold water failure testing

Strainers

To ensure trouble free operation of the fitting, the strainer elements should be checked and cleaned in accordance with the commissioning and servicing guide (see section 8).

To access the strainer element, simply close the isolating valve and unscrew the strainer cap. The strainer element should be washed with clean water and refitted.

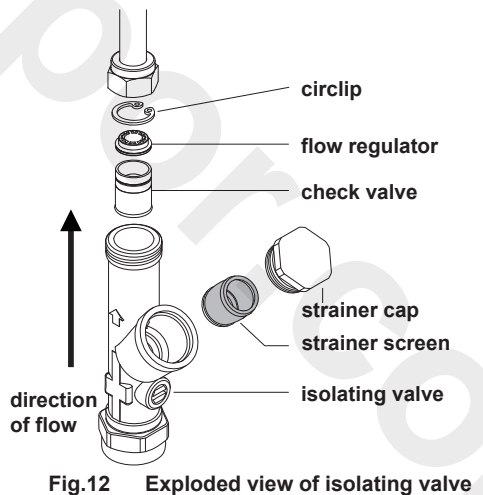
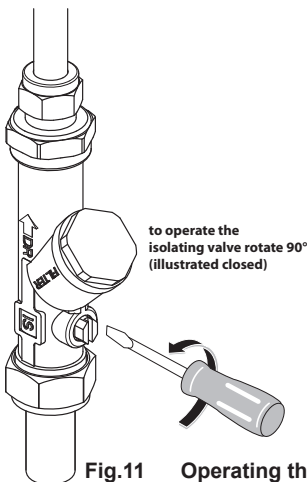

To achieve a suitable flow rate where supply pressures are very low it may be necessary to remove the inline flow regulator.

NOTE: The flow regulator is retained within the valve body by a small circlip. A pair of circlip pliers will be required to remove the regulator.

11 SPARE PARTS

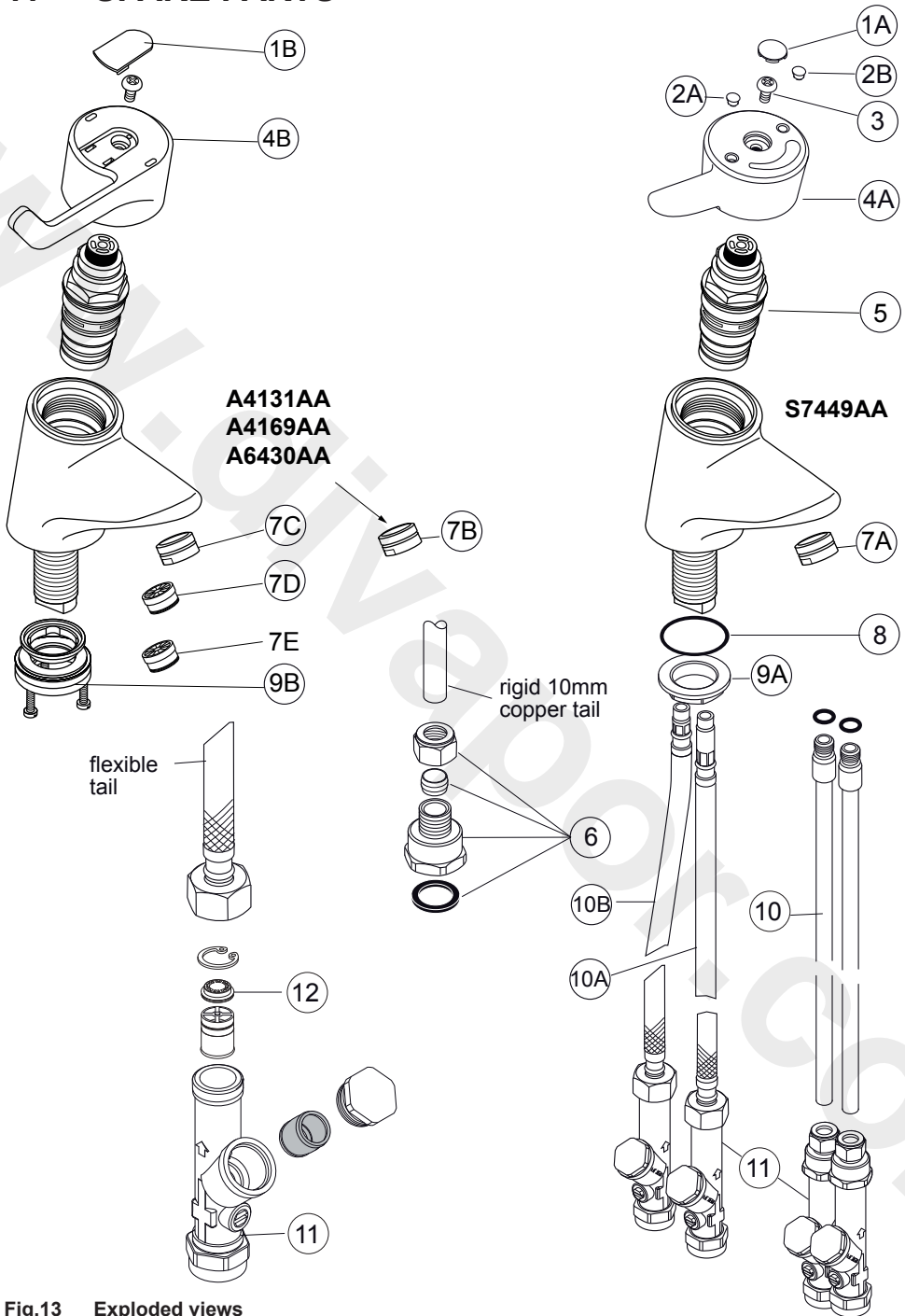

Fig.13 Exploded views

12 SPARE PARTS LIST

Ref.	Description	Product	Part No.
1A 2A 2B	Button, indice, & screw kit	Nuastyle	E960 615AA
1B	Cover cap, non-res, AS logo	Contour21	A962 017AA
3	Handle retaining screw	All	A961 950NU
4A	Lever handle	Nuastyle	E960 669AA
4B	Lever handle	Contour21	A961 823AA
5	Thermostatic cartridge	All	A962 280NU
5	Thermostatic cartridge (10 bulk pack)	All	F960 879NU
6	Couplers –copper tails PAIR	A4169/A6430	F960 882NU
7A	Complete outlet with STD, F/S insert & seal	Nuastyle	A961 625AA
7B	Optional Armitage Bioguard (10 bulk pack with AVK)	All	F961 138AA
7C	Outlet cpl. with AVH, 4.7 L/min PCA insert, seal & AVK.	Contour21	B960 859AA
7D	F/S insert only	Contour21	B960 860NU
7E	2 lpm Spray Insert	A4169	E960 735NU
8	Tap deck seal	Nuastyle	E960 059NU
9A	Back-nut M28x1.5	Nuastyle	H960 098NU
9B	Clamping kit & seal	Contour21	A963 381NU
10	10mm copper tails - PAIR	A4169/A6430	E960 644NU
10A	Flexible inlet tail M10 long	A4169/S7449	E960 642NU
10B	Flexible inlet tail M10 short	A4169/S7449	E960 589NU
11	Isolating valves-PAIR	All	E960 613NU
12	Flow regulator	All	A962 570NU

Abbreviations used:

STD : STandarD housing has spanner flats.

AVH : Anti-Vandal Housing requires special key.

AVK : Anti-Vandal key

F/S : Flow Straightener with full flow.

PCA: Pressure Compensating Aerator.

Most spares are interchangeable between products, please contact customer care.

13 CLEANING CHROME SURFACES

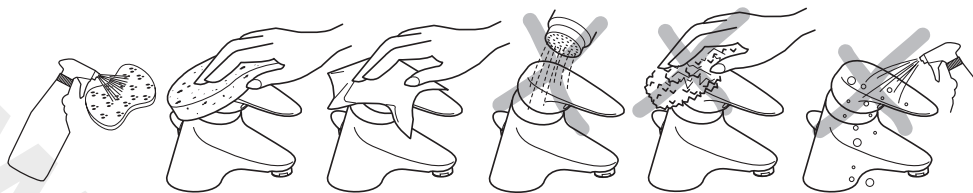

When cleaning chromed products use only a mild detergent, rinse & wipe dry with a soft cloth. Ideally clean after each use to maintain appearance.

Never use abrasive, scouring powders or scrapers. Never use cleaning agents containing alcohol, ammonia, hydrochloric acid, sulphuric acid, nitric acid, phosphoric acid or organic solvents. Use of incorrect cleaning products / methods may result in chrome damage which is not covered by the manufacturer's guarantee.

For more information about our products visit our websites:

www.armitage-shanks.co.uk

www.idealspec.co.uk

www.fastpart-spares.co.uk



AFTER SALES NON RESIDENTIAL HELPLINE
0870 122 8822

AFTER SALES NON RESIDENTIAL FAX
0870 122 8282

E-MAIL
aftersalesnonresidential@idealstandard.com

Armitage Shanks pursues a policy of continuing improvement in design and performance of its products.

This right is therefore reserved to vary specifications without notice.

Armitage Shanks is a division of
Ideal Standard (UK) Ltd

Ideal Standard International NV
Corporate Village - Gent Building
Da Vincilaan 2
1935 Zaventem
Belgium

www.idealstandardinternational.com

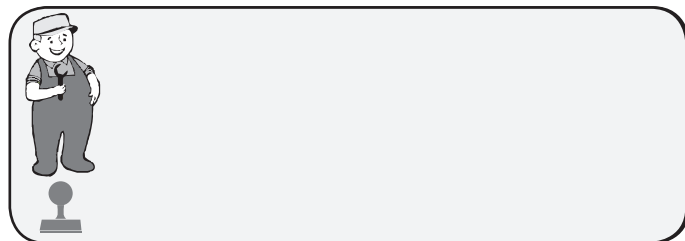

*Armitage
Shanks*

1116 / A 866 448
Made in Germany