

ASPIRANTE
by TRITON

**Aspirante Topaz
thermostatic control
electric shower**



Installation and Operating Instructions

INSTALLERS PLEASE NOTE THESE INSTRUCTIONS ARE TO BE LEFT WITH THE USER

CONTENTS	Page
Important safety information	1
Specifications.....	2
Electrical requirements.....	4
Water requirements	6
Siting of the shower	7
Fitting the shower to the wall.....	9
Plumbing connections	10
Electrical connections	11
Commissioning.....	12
Replacing the cover.....	13
Operating the shower.....	14
Operating functions.....	17
Cleaning.....	19
Instructions for installers and service engineers only	20 - 21
Spare parts	22 - 23
Fault finding	24 - 25
Guarantee, service policy, etc.	rear cover

⚠ WARNING ⚠

This appliance can be used by children aged from 8 years and above and persons with reduced physical, sensory or mental capabilities or lack of experience or knowledge if they have been given supervision or instruction concerning use of the appliance in a safe way and understand the hazards involved. Children may not play with the appliance. Cleaning and user maintenance shall not be made by children without supervision.

To check the product suitability for commercial and multiple installations, please contact Triton's specification advisory service before installation.

Telephone: 024 7637 2222

Facsimile: 024 7632 4504

E mail: technical@tritonshowers.co.uk

PLEASE READ THIS IMPORTANT SAFETY INFORMATION

Products manufactured by Triton are safe and without risk provided they are installed, used and maintained in good working order in accordance with our instructions and recommendations.

- ⚠ WARNING: DO NOT** operate shower if frozen, or suspected of being frozen. It must thaw out before using.
- ⚠ DO NOT** operate the unit if the showerhead or spray hose becomes damaged.
- ⚠ DO NOT** restrict flow out of shower by placing showerhead in direct contact with your body.
- ⚠ DO NOT** operate the shower if water ceases to flow during use or if water has entered inside the unit because of an incorrectly fitted cover.

1 GENERAL

- 1.1** Isolate the electrical and water supplies before removing the cover.
- 1.2** Read all of these instructions and retain them for later use.
- 1.3 DO NOT** take risks with plumbing or electrical equipment.
- 1.4** Isolate electrical and water supplies before proceeding with the installation.
- 1.5** The unit must be mounted onto the finished wall surface (on top of the tiles). **DO NOT** tile up to or seal around **ANY PART** of the unit using silicone sealer after fixing to the wall. Special care must be taken **NOT TO BLOCK OR SEAL ANY PRD VENTS ON THE UNIT.**
- 1.6** Contact Customer Service (*see back page*), if any of the following occur:
 - a)** *If it is intended to operate the shower at pressures above the maximum or below the minimum stated.*
 - b)** *If the unit shows a distinct change in performance.*
 - c)** *If the shower is frozen.*
- 1.7** If it is intended to operate the shower in areas of hard water (above 200 ppm temporary hardness), a scale inhibitor may have to be fitted. For advice on the Scale Inhibitor, contact Customer Service.
- 1.8** The showerhead must be cleaned regularly with descaler to remove scale and debris, otherwise restrictions to the flow on the outlet of the unit will result in higher temperatures and could also cause the (PRD) Pressure Relief Device in the unit to operate.
- 1.9** This product is not suitable for mounting into steam rooms or steam cubicles.

2 PLUMBING

- 2.1** The plumbing installation must comply with Water Regulations, Building Regulations or any particular regulations as specified by Local Water Company or Water Undertakers and should be in accordance with BS EN 806.
- 2.2** The supply pipe must be flushed to clear debris before connecting to the shower unit.

- 2.3 DO NOT** solder pipes or fittings within 300mm of the shower unit, as heat can transfer along the pipework and damage components.
- 2.4 DO NOT** fit any form of outlet flow control as the outlet acts as a vent for the heater can.
- 2.5 DO NOT** use excessive force when making connections to the flexible hose or showerhead, finger tight is sufficient.
- 2.6** All plumbing connections must be completed before making the electrical connections.
- 2.7** This appliance **MUST** not be connected to the inlet supply by a hose-set.

3 ELECTRICAL

- 3.1** The installation must comply with BS 7671 'Requirements for electrical installations' (IEE wiring regulations), building regulations or any particular regulations as specified by the local Electrical Supply Company.
- 3.2** This appliance **MUST** be earthed.
- 3.3** In accordance with 'The Plugs and Sockets etc. (Safety) Regulations 1994', this appliance is intended to be permanently connected to the fixed wiring of the electrical mains system.
- 3.4** Make sure all electrical connections are tight to prevent overheating.
- 3.5** A 30mA residual current device (RCD) **MUST** be installed in all UK electric and pumped shower circuits. This may be part of the consumer unit or a separate unit.
- 3.6** Switch off immediately at isolating switch if water ceases to flow during use.
- 3.7** Other electrical equipment i.e. extractor fans, pumps must not be connected to the circuits within the unit.
- 3.8** Switch off at isolating switch when not in use. This is a safety procedure recommended with all electrical appliances.

- 3.9** As with all electrical appliances it is recommended to have the shower and installation checked at least every two years by a competent electrician to ensure there is no deterioration due to age and usage.

INTRODUCTION

This book contains all the necessary installation and operating instructions for your thermostatic electric shower.

Take time to read this book thoroughly and familiarise yourself with all instructions before installation. Please keep it for future reference.

The shower installation must be carried out by a suitably qualified person and in the sequence of this instruction book.

Care taken during the installation will provide a long, trouble-free life from your shower.

SPECIFICATIONS

Electrical

Nominal power rating at 240V	Nominal power rating at 230V
9.5kW – (40A MCB rating)	8.7kW – (40A MCB rating)
10.5kW – (45A MCB rating)	9.6kW – (45A MCB rating)

Water

Inlet connection – 15 mm diameter.
Outlet connection – ½" BSP male thread.

Entry Points

Water – **Right:** middle back, bottom, top.
Cable – **Right:** middle back, bottom, top.

Materials

Backplate, cover, controls, showerhead – ABS.
Sprayplate – Acetal.
Elements – Minerally insulated corrosion resistant metal sheathing.

Dimensions

Height – 335 mm
Width – 225 mm
Depth – 95 mm

Standards and Approvals

Waterproof rating IPX4.

Complies with the requirements of current British and European safety standards for household and similar electrical appliances.

Complies with requirements of the British Electrotechnical Approvals Board (BEAB).

Meets with Compliance with European Community Directives (CE).

UNDERSTANDING YOUR SHOWER

IMPORTANT: When first installed the unit will be empty. It is essential the unit should contain water before the elements are switched on. As this unit has electronic control, it is vital that the commissioning procedure is followed. Failure to carry out this operation will result in damage to the unit and will invalidate the guarantee.

Temperature/flow rate

The temperature control on the unit can be adjusted to provide shower temperatures nominally between 35°C and 47°C. The unit will give higher and lower temperatures if given extreme supply conditions.

Note: The maximum flow rate for the given temperature will be greater in the summer than in winter because of ambient temperature variance of the mains water supply.

It is strongly advised to select economy power during periods of hot weather, otherwise at all other times, leave the power setting at full to provide the maximum flow rate.

Safety cut-out

The unit is fitted with a non-resettable over-temperature safety device. In the event of abnormal operation which could cause unsafe temperatures within the unit, the device will disconnect the heating elements. It will require a visit from a qualified engineer to determine the nature of the fault and replace the safety device, once the unit has been repaired.

Replacement parts can be ordered from Customer Service. See 'spare parts' for details and part numbers.

MAIN COMPONENTS

Inside unit (fig.1)

1. Top cable/pipe entry
2. Bottom cable/pipe entry
3. Wall screw fixings
4. Power printed circuit board
5. Thermal cut-out
6. Can and element assembly
7. Ribbon cable connector
8. Terminal block
9. Earth connection
10. PRD
11. Solenoid valve
12. Trimplate
13. Thermostatic valve
14. Scale trap
15. Pressure switch
16. Shower outlet
17. Guide pockets

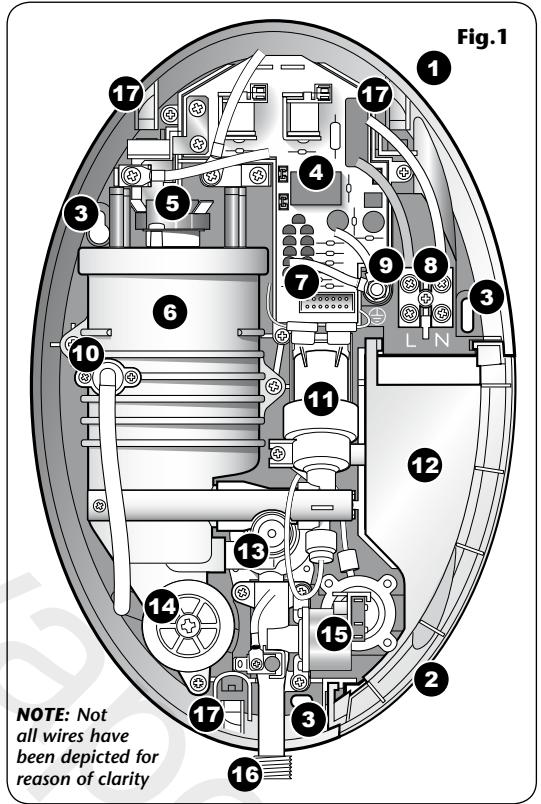

Inside cover (fig.2)

18. Control printed circuit board
19. Start/Stop printed circuit board
20. Cover tags
21. Ribbon cable

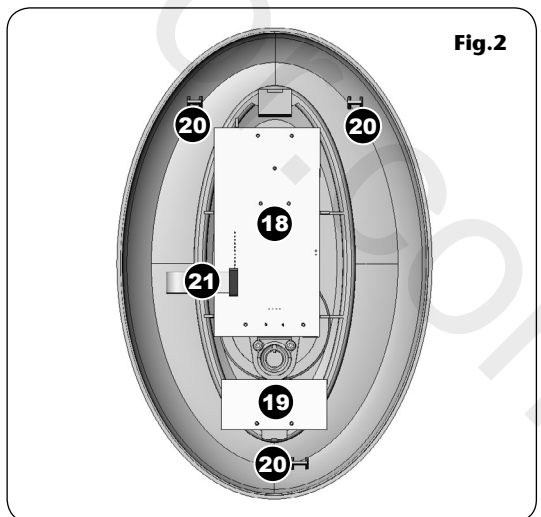

ELECTRICAL REQUIREMENTS

⚠ WARNING! ⚠
THIS APPLIANCE MUST BE EARTHED

The installation, supply cable and circuit protection must conform with BS 7671 (IEE wiring regulations) and be sufficient for the amperage required.

The following notes are for guidance only:

- 1 The shower must only be connected to a 230-240V ac supply. If you are installing a shower with a kilowatt rating above 9kW, it is advisable to contact the local electricity supply company.
- 1.1 The electrical rating of the shower is shown on the rating label (**Fig.3**) within the unit.
- 2 Before making any sort of electrical connection within the installation make sure that no terminal is live. If in any doubt, switch off the whole installation at the mains supply and remove the correct fuse.
- 3 The shower must be connected to its own independent electrical circuit. **IT MUST NOT** be connected to a ring main, spur, socket outlet, lighting circuit or cooker circuit.
- 3.1 The electrical supply must be adequate for the loading of the unit and existing circuits.
- 4 Check your consumer unit (main fuse box) has a main switch rating of 80A or above and that it has a spare fuse way which will take the fuse or Miniature Circuit Breaker (MCB) necessary for the shower (**Fig.4**).
- 4.1 If your consumer unit has a rating below 80A or if there is no spare fuse way, then the installation will not be straightforward and may require a new consumer unit serving the house or just the shower.
- 4.2 You will need to contact the local electricity company. They will check the supply and carry out what is necessary.
- 5 For close circuit protection **DO NOT** use a rewirable fuse. Instead use a suitably rated Miniature Circuit Breaker (MCB) or cartridge fuse (**see Table A**).
- 5.1 A 30mA residual current device (RCD) **MUST** be installed in all UK electric and pumped shower circuits. This may be part of the consumer unit or a separate unit.

Fig.3

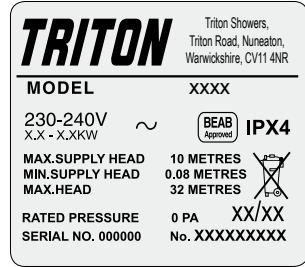

Fig.4 Schematic of installation circuit

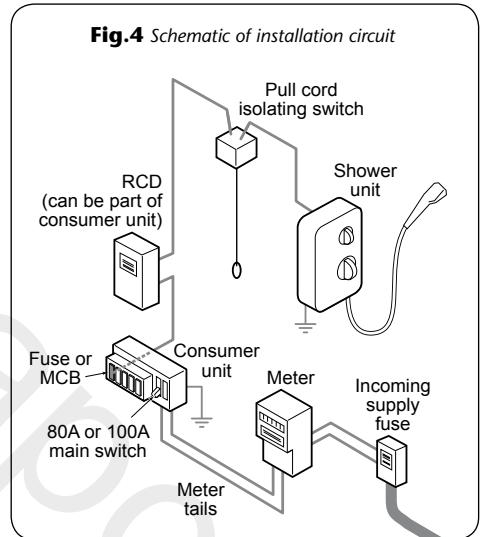

Table A

unit rating	CIRCUIT PROTECTION	
	MCB	cartridge fuse
7.0kW	30/32A	30A
7.5kW	32A	35A
8.0kW	40A	35A
8.5kW	40A	45A
9.0kW	40A	45A
9.5kW	40/45A	45A
10.5kW	45A	45A

- 6 A 45 amp double pole isolating switch with a minimum contact gap of 3 mm in both poles must be incorporated in the circuit.
- 6.1 It must have a mechanical indicator showing when the switch is in the OFF position, and the wiring must be connected to the switch without the use of a plug or socket outlet.
- 6.2 The switch must be accessible and clearly identifiable, but out of reach of a person using a fixed bath or shower, except for the cord of a cord operated switch, and should be placed so that it is not possible to touch the switch body while standing in a bath or shower cubicle. It should be readily accessible to switch off after using the shower.
- 7 Where shower cubicles are located in any rooms other than bathrooms, all socket outlets in those rooms must be protected by a 30mA RCD.
- 8 The current carrying capacity of the cable must be at least that of the shower circuit protection (see Table B).
- 8.1 To obtain full advantage of the power provided by the shower, use the shortest cable route possible from the consumer unit to the shower.
- 8.2 It is also necessary to satisfy the disconnection time and thermal constraints which means that for any given combination of current demand, voltage drop and cable size, there is a maximum permissible circuit length.
- 9 The shower circuit should be separated from other circuits by at least twice the diameter of the cable or conduit.
- 9.1 The current rating will be reduced if the cabling is bunched with others, surrounded by thermal loft or wall insulation or placed in areas where the ambient temperature is above 30°C. Under these conditions, derating factors apply and it is necessary to select a larger cable size.
- 9.2 In the majority of installations (see Table B), the cable will unavoidably be placed in one or more of the above conditions. This being so, it is strongly recommended to use a minimum of 10mm cabling throughout the shower installation.

- 9.3 In any event, it is essential that individual site conditions are assessed by a competent electrician in order to determine the correct cable size and permissible circuit length.

Table B

**Twin and earth PVC insulated cable
Current carrying capacity**

Installed in an insulated wall	In conduit trunking	Clipped direct or buried in a non-insulated wall
6mm ² 32A	6mm ² 38A	6mm ² 46A
10mm ² 43A	10mm ² 52A	10mm ² 63A
16mm ² 57A	16mm ² 69A	16mm ² 85A

Note: Cable selection is dependent on derating factors

***The method below may be used by installers to determine the approximate size of the incoming cable.**

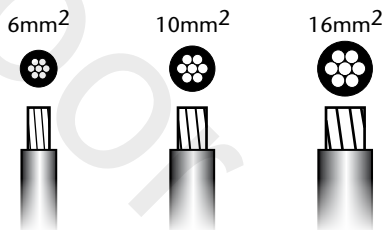

1. Measure the width of an individual strand, and half that measurement to find (r), e.g: $1.34\text{mm} \div 2 = (r) 0.67\text{mm}$
2. Multiply (r) x (r) x 3.14, e.g: $(r) 0.67 \times (r) 0.67 \times 3.14 = 1.41\text{mm}^2$
3. Multiply this by the number of wire strands (usually 7), e.g: $1.41\text{mm}^2 \times 7 = 9.87\text{mm}^2$.
4. The number obtained would suggest 10mm² wiring.

***PLEASE NOTE:** If unsure, consult a qualified Electrician.

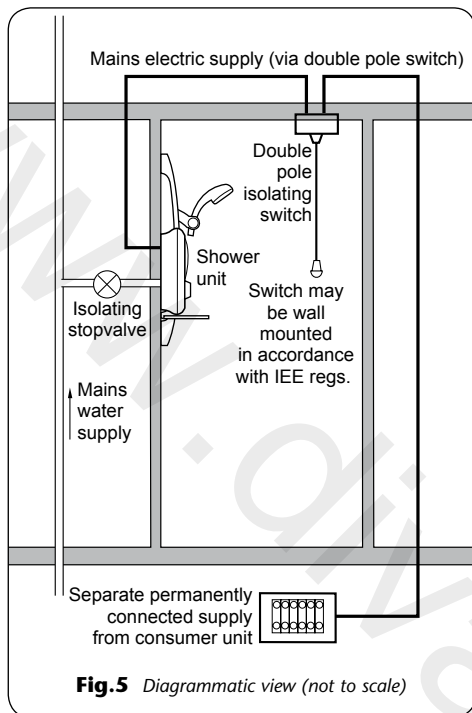

Fig.5 Diagrammatic view (not to scale)

WARNING!

The shower must not be positioned where it will be subjected to freezing conditions.

WATER REQUIREMENTS

The installation must be in accordance with Water Regulations/Bylaws.

To guarantee activating the heating elements, the shower must be connected to a mains water supply with a minimum running pressure of 100kPa (1.0 bar) at a minimum flow rate of nine litres per minute with a maximum static pressure of 1 000kPa (10 bar).

Note: For the 10.5kW rated shower, the minimum running pressure must be 150kPa (1.5 bar) at a minimum flow rate of eleven litres per minute with a maximum static pressure of 1 000kPa (10 bar). If the stated flow rates are not available, it may not be possible to achieve ideal performance from the unit throughout the year.

For guidance on the running and static pressures contact the local Water Authority or consult a competent plumber.

Under site conditions where the power supply is below 220 volts and the mains water pressure is above 5 bar, it is recommended to fit a pressure reducing valve set at 3.5 bar.

A typical system layout is shown in **fig.5**.

DO NOT use jointing compounds on any pipe fittings for the installation.

During periods of high ambient water temperatures it may be necessary to select a low power setting to achieve your preferred shower temperature. The water supply can be taken from a cold water storage cistern provided there is a minimum head of ten metres above the showerhead (fifteen metres for the 10.5kW rated shower). It must be an independent supply to the shower only.

If it is intended to operate the shower at pressures above the maximum or below the minimum stated, contact Customer Service.

SITING OF THE SHOWER

WARNING!

The shower must not be positioned where it will be subjected to freezing conditions.

always mount the unit on the surface of the tiles. NEVER tile up to the unit.

Refer to **fig.6** for correct siting of the shower.

Position the unit where it will NOT be in direct contact with water from the showerhead.

Position the shower unit vertically.

Allow enough room between the ceiling and the shower to access the cover top screws.

Note: Water regulations require the showerhead be 'constrained by a fixed or sliding attachment so that it can only discharge water at a point not less than 25 mm above the spill-over level of the relevant bath, shower tray or other fixed appliance'. The use of the supplied soap dish will in most cases meet this requirement, but if the showerhead can be placed within a bath, basin or shower tray, then a double check valve, or similar, must be fitted in the supply pipework to prevent back-flow.

IMPORTANT: Using a suitable sealant, always seal around the incoming pipework to prevent water entering the wall.

Liquid Crystal Display

This shower unit has a LCD which has an optimum viewing angle that is slightly below eye level. Therefore position the unit so the display is at nose level. For multiple users of varying heights, an optimum shower height must be arrived at.

Pressure relief safety device

A pressure relief device (PRD) is designed into the shower unit which complies with European standards. The PRD provides a level of appliance protection should an excessive build up of pressure occur within the shower.

DO NOT operate the shower with a damaged or kinked shower hose, or a blocked showerhead which can cause the PRD to operate.

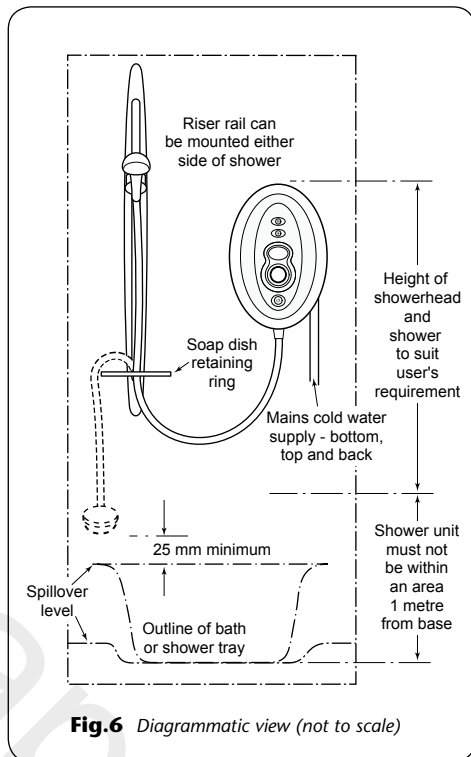
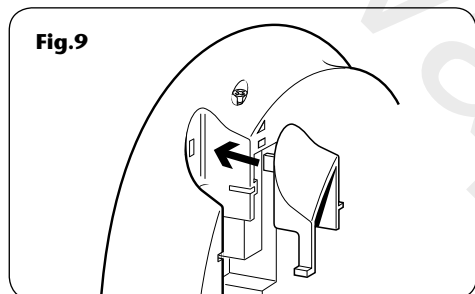
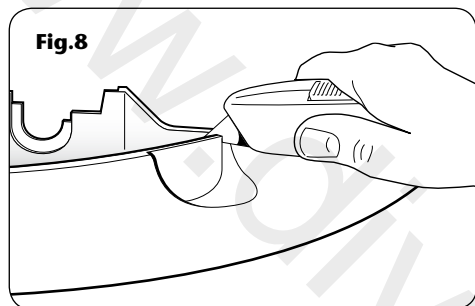
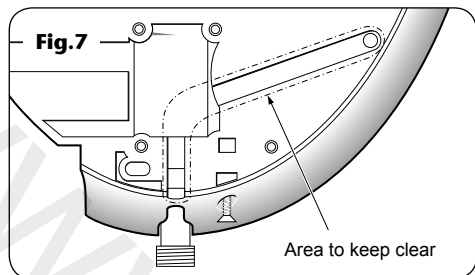

Fig.6 Diagrammatic view (not to scale)

IMPORTANT: The unit must be mounted on a flat surface which covers the full width and length of the backplate, otherwise difficulty may arise when fitting the cover and subsequent operation of the unit may be impaired.



Make sure the PRD outlet at the bottom of the unit is not blocked (**fig.7**).

When commissioning, the showerhead must be removed from the flexible hose. Failure to follow this procedure may cause the PRD to operate.

Make sure the shower is positioned over a bath or shower tray because if the PRD operates, then water will eject from the bottom of the unit.

Should this happen, turn off the electricity and water supplies to the shower at the isolating switch and stopvalve. Contact Customer Service for advice on replacing the PRD.

WARNING!

If using a silicon seal around the backplate edge, make sure the PRD exit behind the outlet pipe is kept clear.

FITTING THE SHOWER TO THE WALL

Note: The control knob is an integral part of the cover – DO NOT attempt to remove it.

Unscrew the two top and one bottom retaining screws. There is no need to completely remove the screws, just enough to lift the cover from the backplate. To allow access to the pipe and cable connections remove the trimplate by lifting away from the backplate.

Entry positions for the mains water are from the top, bottom or back. Cable entry is via the top, bottom or back.

Note: Deviations from the designated entry points will invalidate product approvals.

If bottom surface entry is required, then the necessary hole will need to be cut out in the 'thinned section' of the trimplate using a suitable tool and file (**fig.8**).

If bottom or rear entry is chosen, the pipe trim will need to be fitted in the top entry position on the backplate (**fig.9**).

If installing a supply pipe from the rear or bottom, the centre of the inlet valve to the wall surface is 21 mm (**fig.10**).

Note: If entry is from the rear, the nut of the compression fitting will be partially behind the surface of the wall. This area MUST be left clear when plastering over the pipework in order to make the nut accessible for future adjustments.

After choosing the site for the shower, use the backplate as a template and mark the three wall fixing holes (**fig.11**).

Drill and plug the wall.

(An appropriate drill bit should be used. If the wall is brick, plasterboard or a soft building block, appropriate wall plugs and screws should be fitted).

Screw the top left-hand fixing screw into position leaving the base of the screw head protruding 6 mm out from the wall.

Hook the backplate over this screw, then fit the other two fixing screws into position.

Do not fully tighten the screws at this stage, as the fixing holes are elongated to allow for out of square adjustment after the plumbing connections have been completed.

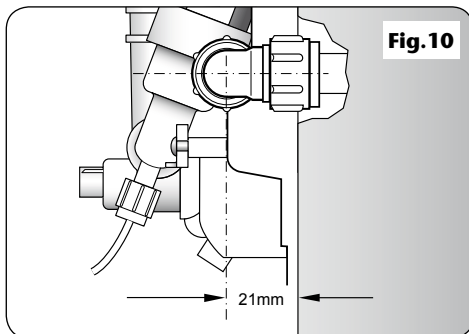

Fig.10

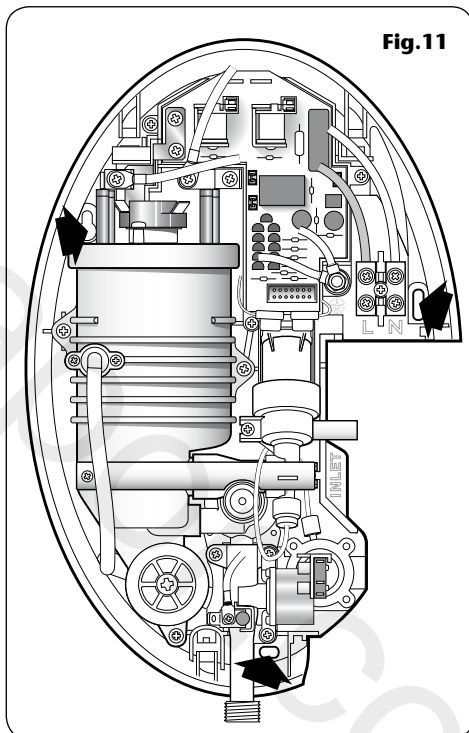
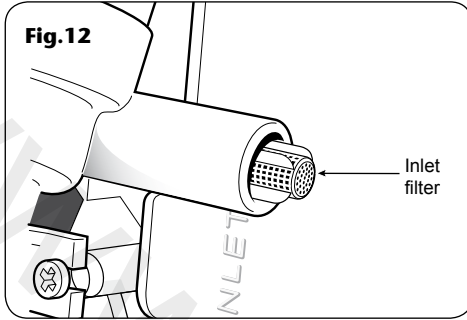

Fig.11



WARNING!

The outlet of the shower acts as a vent and must not be connected to anything other than the hose and showerhead supplied.

PLUMBING CONNECTIONS

Plumbing to be carried out before wiring

DO NOT use jointing compounds on any pipe fittings for the installation.

DO NOT solder fittings near the shower unit as heat can transfer along the pipework and damage components

Standard brass compression fittings MUST be used to connect to the inlet of the shower.

Note: An additional stopvalve (complying with Water Bylaws/Regulations) MUST be fitted in the mains water supply to the shower as an independent means of isolating the water in order to carry out maintenance or servicing.

IMPORTANT: Before completing the connection of the water supply to the inlet of the shower, and in compliance with Water Regulations, flush out the pipework to remove all swarf and system debris. To do this, connect a hose to the pipework and turn on the mains water supply long enough to clear the debris to waste.

Procedure

Turn off the water supply either at the mains stopvalve or the isolating stopvalve. Connect the mains water supply to the inlet (**fig.12**) of the shower via 15 mm copper, stainless steel or plastic pipe using a 15 mm x 15 mm brass compression fitting. The plastic filter protrudes from the inlet so check it is in place before connection.

Note: The inlet fitting is designed to enter a compression fitting only. DO NOT use push fit connectors as full engagement cannot be guaranteed. DO NOT use excessive force when making these connections.

Make sure the backplate is square on the wall and tighten the two retaining screws which hold it to the wall.

Turn on the mains water supply and check for leaks in the pipework connection to the shower.

IMPORTANT: Using a suitable sealant, always seal around the incoming pipework to prevent water entering the wall.

Note: At this stage no water can flow through the unit.

ELECTRICAL CONNECTIONS

SWITCH OFF THE ELECTRICITY SUPPLY AT THE MAINS.

Fig.13 shows a schematic wiring diagram.

The cable entry points are shown in **fig.1**.

The cable can be surface clipped, hidden or via 20 mm conduit.

Note: Conduit entry can only be from rear. Route the cable into the shower unit and connect to the terminal block as follows:

Earth cable to terminal marked **E** 

Neutral cable to terminal marked **N**

Live cable to terminal marked **L**

IMPORTANT: Fully tighten the terminal block screws and make sure that no cable insulation is trapped under the screws. Loose connections can result in cable overheating.

Note: The supply cable earth conductor must be sleeved. The outer sheath of the supply cable must be stripped back to the minimum.

The supply cable must be secured either by routing through conduit or in trunking or by embedding in the wall, in accordance with current IEE regulations.

The use of connections within the unit, or other points in the shower circuit, to supply power to other equipment i.e. extractor fans, pumps etc. will invalidate the guarantee.

DO NOT switch on the electricity supply until the cover has been fitted.

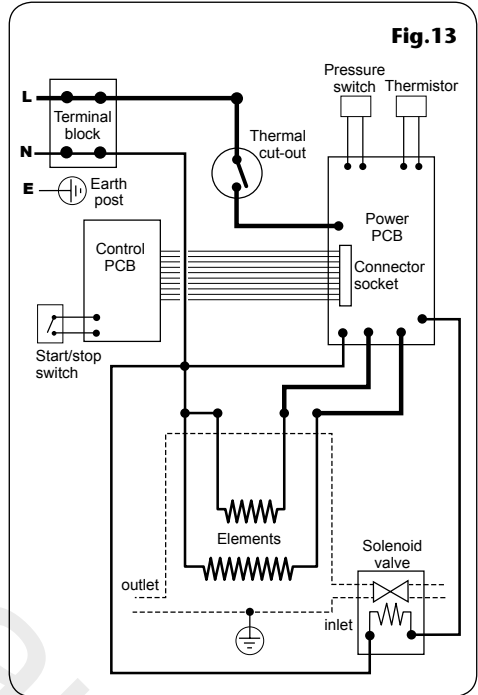

Note: The elements on UK models are to 240V specification and will give a lower kW rating if the voltage supply is below 240V.

WARNING!

Before normal operation of the shower, it is essential the following commissioning procedure is completed correctly.

Fig.14

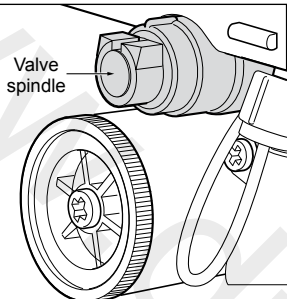

Fig.15



COMMISSIONING

The first operation of the shower is intended to flush out any remaining system debris and to make sure water is purged through the unit so that the heater unit contains water before the elements are switched on.

Refit the trimplate by carefully guiding into the locating slots in the backplate.

At this stage, the cover is temporarily fitted in order to carry out the commissioning procedure.

- a.** Offer the cover to the unit. DO NOT connect the 14-way ribbon cable at this stage.
- b.** Make sure the valve spindle has the 'flat' and keyway slot uppermost (12 o'clock position). See **fig.14**.
- c.** Make sure the temperature control knob on the cover has 'TRITON' horizontal with the blue/red graphics at the top – the knob 'flat' inside the cover should be uppermost (**fig.15**).
- d.** Carefully locate the cover tags into the guide pockets on the backplate and check the wires are not trapped.
- e.** Guide into position so that the control spindle locates correctly (the 'flats' only allow the spindle and knob only fit one way).

Should any difficulty arise, recheck the points above.

While applying slight pressure to the front cover, secure in position with the three retaining screws.

Fit the flexible hose, *without* the showerhead, to the shower outlet, with the outlet of the hose directed to waste. Check the supplied sealing washer is in place.

Turn on the water supply to the shower at the isolating stopvalve. Switch on the electricity supply to the shower at the isolating switch. Water will start to flow through the unit and discharge from the flexible hose.

It will take about thirty seconds for a smooth flow of water to be obtained while air and any debris is being flushed from the shower. When a smooth flow of water is obtained, disconnect the electricity supply to the shower at the isolating switch. This will stop the water flow.

Unscrew the cover retaining screws again and lift the cover from the backplate.

Attached to the control PCB, inside the cover, is a 14-way ribbon cable. The ribbon cable connector must be plugged into the socket located on the power PCB inside the unit (**fig.16**). The connector can only be correctly plugged in one way by virtue of a location lug on the plug. The ribbon cable also has a coloured edge which is on the right-hand side when correctly fitted to the socket.

REPLACING THE COVER

IMPORTANT: Before finally fitting the cover, the following steps must be taken:

- a. Check all plumbing connections are water tight.
- b. Check terminal block screws are fully tightened.
- c. Make sure the pipe and cable entering the unit do not prevent the cover locating correctly to the backplate.
- d. Make sure the valve spindle has the 'flat' and keyway slot uppermost (12 o'clock position).
- e. Make sure the temperature control knob on the cover has 'ASPIRANTE' horizontal with the blue/red graphics at the top (the knob 'flat' inside the cover should be uppermost).

Offer the cover to the unit. Carefully locate the cover tags into the guide pockets on the backplate and check the wires are not trapped. Guide into position so that the control spindle locates correctly (the 'flats' only allow the spindle and knob will only fit one way). While applying slight pressure to the front cover, secure in position with the three retaining screws.

The flexible hose can be left attached to the shower outlet. Make sure the supplied sealing washer is fitted.

Once the riser rail kit is installed, the shower is ready for normal operation.

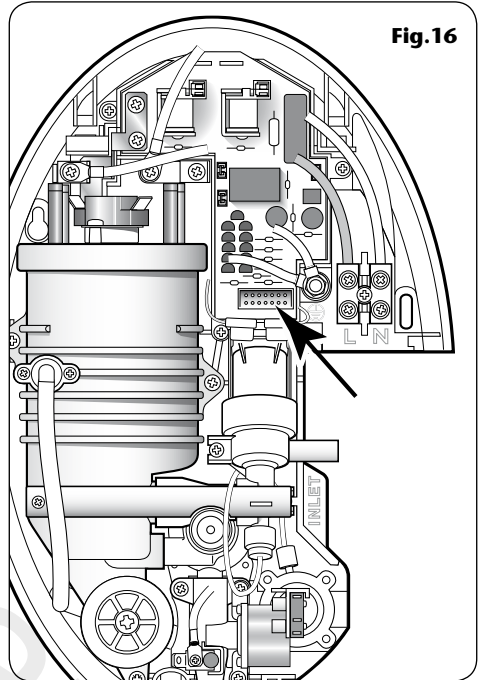

Fig.16

When positioning the trimplate into the locating grooves on the backplate, make sure the cable protector is pushed in sufficiently, so it does not catch on the trimplate.



COVER RETAINING SCREWS

ONLY the **SUPPLIED SCREWS** should be used. The use of none supplied screws **WILL** invalidate product specifications & warranty.

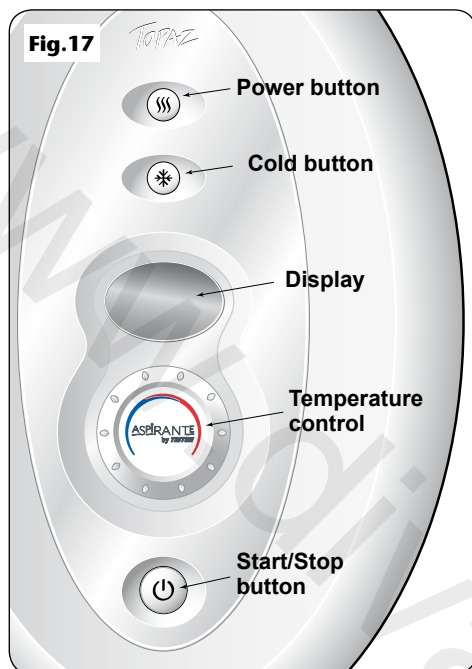

OPERATING THE SHOWER

WARNING!

Before normal operation of the shower, it is essential that the commissioning procedure has been completed correctly.

The shower controls are shown in **fig.17**.

CAUTION: It is recommended that persons who may have difficulty understanding or operating the shower controls should not be left unattended while using the shower. Special consideration should be given to young children and the less able bodied.

Make sure the water supply is turned fully on. Switch the electric supply back on at the isolating switch.

Immediately, the start up routine commences and the display flashes all information for three seconds (**fig.18**).

The display then shows 'OK' in a blue backlight (**fig.19**). It will remain in this standby mode until the shower is started.

To start the shower

Press the START/STOP button  and water will flow.

The display shows 'FUL' (**fig.20**) indicating full power is being used.

After a few seconds, two 'up arrows' start flashing indicating the unit is working towards its preset showering temperature (**fig.21**). This is achieved shortly when the display shows the temperature as °C.

To stop the shower

Press the START/STOP button and the phased shutdown will begin. The current temperature and segments are replaced with a flashing 'SD' and 'SHUTTING DOWN' alternating on the display (**fig.22**). Water stops flowing after a few seconds after which the display returns to 'OK'.

The shower can be left in this standby mode ready for the next immediate user, otherwise, switch off at the isolating switch.

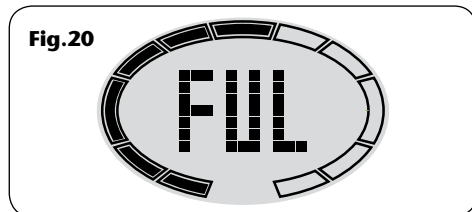
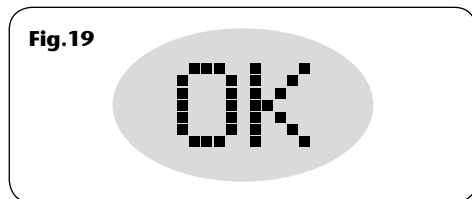
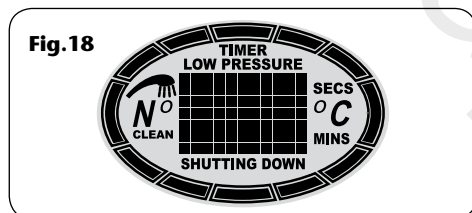

Control buttons

Apart from the START/STOP button, there are two other control buttons – POWER and COLD.

The button marked ☼ is for COLD water only. When pressed the current display is replaced by 'CLD' (fig.23). It remains in this state until the power button is pressed. Adjusting the temperature control at this setting has no effect on the force of the water from the showerhead.

The button marked Ⓜ is the POWER button which is a toggle switch between full power and economy power.

Economy is for using less power when the ambient mains water temperature is high during hot months.

If the shower is on full power and the power button is pressed, the current display is replaced by 'ECO' for five seconds (fig.24). During this time, the flow rate decreases to try to achieve the same temperature as before.

Note: If the setting was high at full power, then it will not be possible to obtain the same temperature on economy power. The shower will try to provide the highest temperature at the best flow rate.

Note: If the stated flow rate required for the unit cannot be met due to low water pressure, it will be necessary to operate the shower on economy power during hot months because of flow rate limitations entering the unit.

Full is the maximum power setting which allows the highest flow achievable for your preferred temperature.

If the shower is on economy power or the cold setting and the power button is pressed, the current display is replaced by 'FUL' for five seconds (fig.25). During this time the flow rate increases to achieve the same temperature as before or to correspond to the current temperature control position.

It is advisable to leave the power setting at full at all times, except during periods of hot weather.

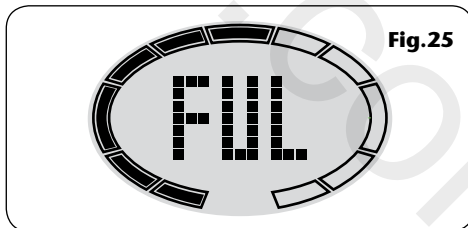
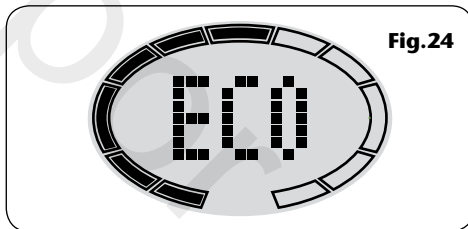
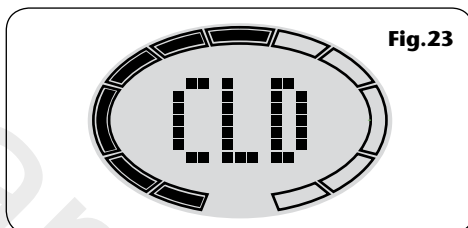
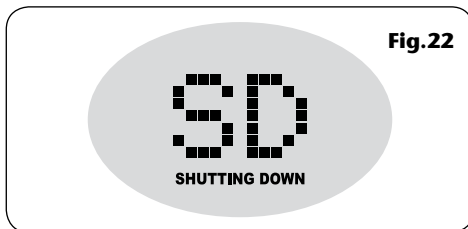
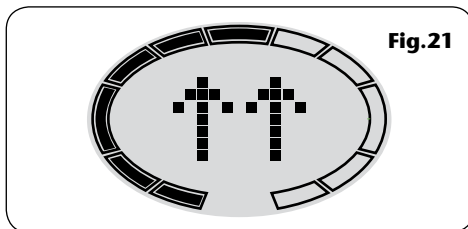

Fig.26

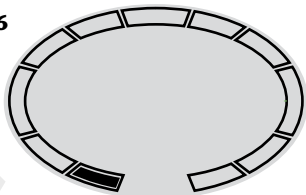

Fig.27



Fig.28

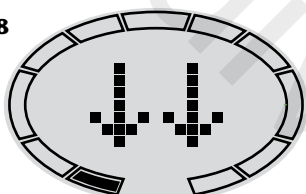
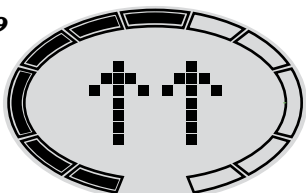

Fig.29



To adjust the shower temperature

The showering temperature is varied by turning the temperature control which changes the mix of hot water coming from the heater can and the incoming cold water. On the display circumference are eleven outer segments which represent the total angular movement of the temperature control. Rotating the temperature control causes inner segments to fill, indicating the actual position of the control relative to its minimum and maximum limits.

Minimum temperature (**fig.26**) position (one inner segment full that corresponds to the control position).

Maximum temperature (**fig.27**) position (all inner segments full that corresponds to the control position).

To decrease the shower temperature

Turn the temperature control anti-clockwise; the current temperature display is replaced by two flashing 'down arrows' (**fig.28**). Five seconds later the display shows the revised temperature.

To increase the shower temperature

Turn the temperature control clockwise; the current temperature display is replaced by two flashing 'up arrows' (**fig.29**). A few seconds later the display shows the revised temperature.

Note: It is advisable to be certain that the showering temperature is satisfactory by testing with your hand before stepping under the showerhead.

There will always be a time delay of a few seconds between selecting a temperature and the water reaching the stable selected temperature.

OPERATING FUNCTIONS

Clean showerhead

After a preset number of START/STOP button operations (nominally 75), the start up routine acts as normal but instead of a blue 'OK' the display backlight turns red and a flashing 'CS' the display backlight turns red and a flashing 'showerhead symbol' alternating with a flashing 'showerhead symbol' and 'CLEAN' appear (**fig.30**).

This is a reminder to clean the showerhead. It does NOT indicate a defect to the shower.

To remove the red 'CS' from the display, press the power and cold buttons simultaneously for three seconds. Alternatively you can choose not to remove the flashing indication and carry on by pressing the START/STOP button and showering as normal, but the 'symbol' and 'CLEAN' will continue to flash at the side of the °C figure for a further five shower operations after which time it will stop (whether you clean the showerhead or not). The shower will then reset automatically for a further preset number of shower operations before flashing the reminder again.

Low pressure

When the display backlight turns red and 'LP' and 'LOW PRESSURE' flash alternately, it means the water pressure has fallen below the minimum required for correct operation of the shower (**fig.31**). This causes the low pressure switch to operate and this turns off power to the heating elements preventing any maintained temperature rises. Water will no longer flow until the unit has been reset.

Press the START/STOP button once to reset the shower. The shower will shut down and then begin its start up routine.

If there is still not enough pressure for correct operation the 'LOW PRESSURE' display will flash once more and the shower will require resetting again.

If there is enough pressure the display will change to show 'OK' in a blue backlight and the shower will run as normal.

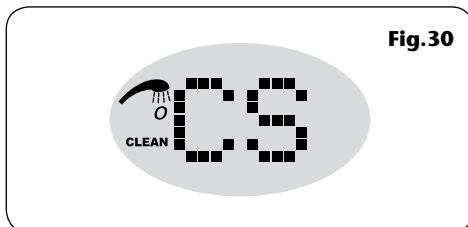

Fig.30

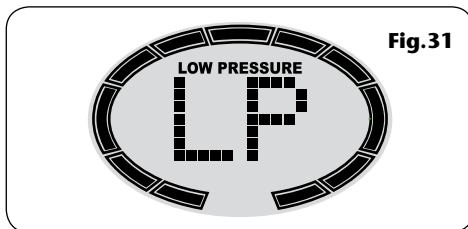

Fig.31

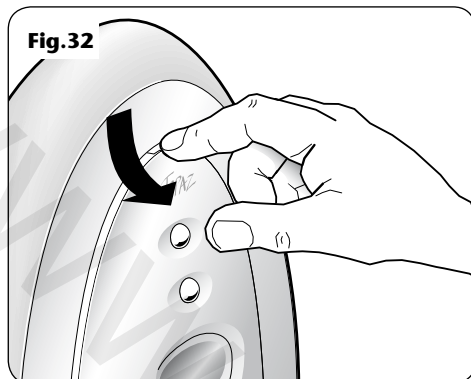

Fig.32

WARNING!

After any servicing of mains water supply, always make sure the unit is started on COLD in order to purge any air in the pipework.

Phased shutdown

In use, when the START/STOP button is pressed, power is switched off to the elements and the power indicator will extinguish. The display will change to a flashing 'SD'. Water continues to flow for a few seconds, flushing out any remaining hot water. This makes sure the next immediate user will not receive a slug of hot water if standing under the showerhead when starting the shower.

Safety cut-out

The shower is fitted with a thermal cut-out safety device. In the event of abnormal operation which could cause unsafe temperatures within the unit, the device will disconnect the heating elements.

It will require a visit from a qualified engineer to determine the nature of the fault and replace the safety device, once the unit has been repaired.

Changing the fascia

This shower unit has the facility for the coloured fascia to be simply changed for another colour of your choice. The coloured options are available as low cost accessories and are listed in the 'parts list' section at the rear of this booklet.

The top of the fascia has a recessed cutaway. With your finger, just press down in the cutaway and pull away (**fig.32**). To replace the fascia, position the lower end into the recess of the cover and push fit the top into position.

Note: In normal use, it is in order to leave the water supply permanently on to the shower unit, but as with most electrical appliances, **the unit must be switched off at the isolating switch when not in use.**

CLEANING

Before cleaning, turn off the unit at the isolation switch to avoid the shower being accidentally switched on.

Triton recommends that all products are cleaned using warm, soapy water.

DO NOT use abrasive or aggressive chemical cleaning products as this may affect the product surface finish and invalidate your guarantee.

IT IS IMPORTANT TO KEEP THE SHOWERHEAD CLEAN TO MAINTAIN THE PERFORMANCE OF THE SHOWER. The hardness of the water will determine the frequency of cleaning. For example, if the shower is used every day in a very hard water area, it may be necessary to clean the showerhead on a weekly basis.

WARNING!

DO NOT use abrasive or aggressive cleaning products when cleaning the shower as they may damage the unit.

INSTRUCTIONS FOR INSTALLERS AND SERVICE ENGINEERS ONLY

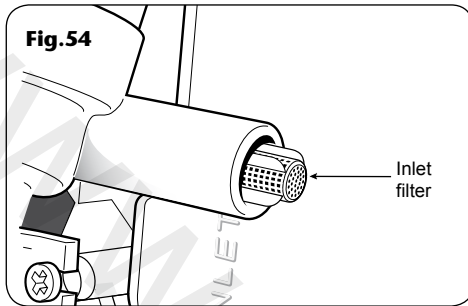

CLEANING THE INLET FILTER

It is recommended that the filter is periodically cleaned in order to maintain the performance of the shower. It is essential that this operation is carried out by a competent person.

SWITCH OFF THE ELECTRICITY SUPPLY AT THE MAINS.

Remove the cover. The inlet filter is situated in the solenoid inlet (**fig.54**) and can be removed to clean.

To gain access to the filter will require the trimplate to be removed and disconnection and removal of the compression fitting. Also, depending on the incoming pipework arrangements, if there is not enough slack in the pipework, it could mean the removal of the unit from the wall.

When cleaning the plastic filter, DO NOT use a sharp object, as it will cause damage. It is preferable to use an old toothbrush or similar.

INSTRUCTIONS FOR INSTALLERS AND SERVICE ENGINEERS ONLY

CLEANING THE SCALE TRAP

It is recommended in hard water areas, the scale trap is periodically cleaned to maintain the performance of the shower.

It is essential that this operation is carried out by a competent person.

SWITCH OFF THE ELECTRICITY SUPPLY AT THE MAINS.

Remove the cover and unplug the ribbon cable. The scale trap is located at the lower left-hand side of the unit. Unscrew the single central screw (**fig.55**) then pull off the cap complete with 'O' rings.

Be aware of water discharging as the heater can exhausts.

Clean out the trap and remove all sediment. Flush the can through by leaving the cap off and switching on the power at the isolating switch.

Note: Check the water that flows out of the scale trap will safely flow to waste.

Switch the power off at the isolating switch. Replace the cap, making sure the 'O' rings are in place and free from debris. Secure with the central screw.

Switch the power back on again at the isolating switch to enable the can to fill with water. Check for water leakage at the scale trap. When water flows smoothly from the showerhead, stop the flow by switching the power off at the isolating switch.

Reconnect the ribbon cable and replace the cover and secure with the three screws.

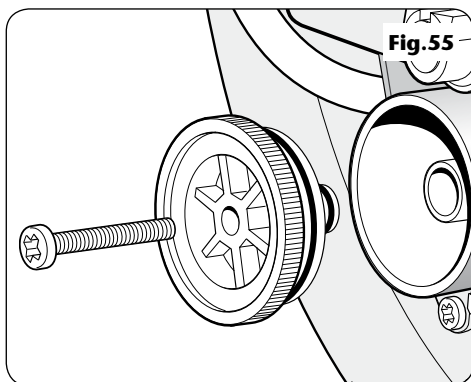

SPARE PARTS

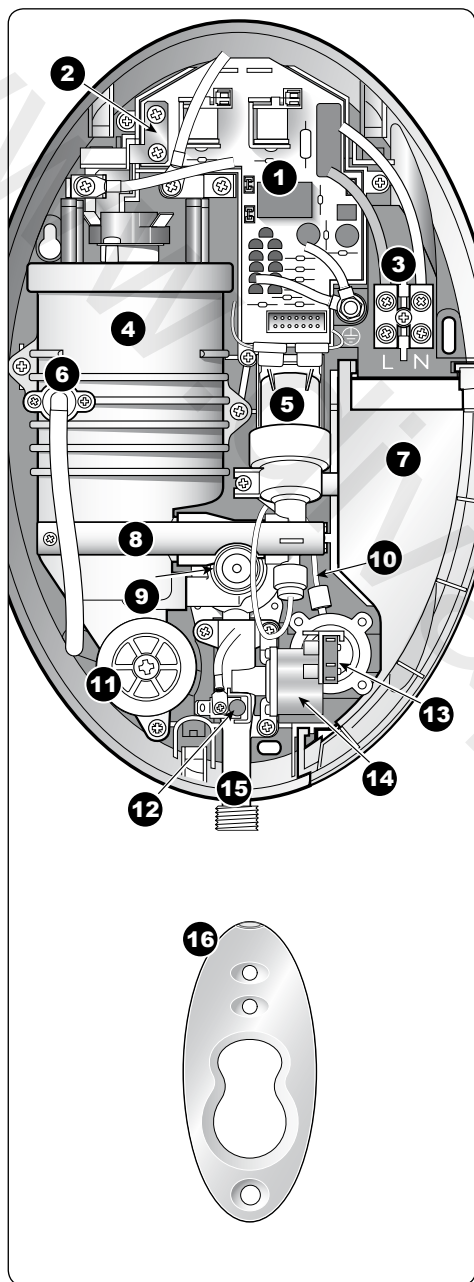

Ref. Description	Part No.
1. Power PCB	7073730
2. Copper Bus Bar	7023005
3. Terminal Block & Wires.....	S07720905
4. Can Assembly 9.5kW.....	83307090
10.5kW	83307100
Flow Regulator 3.0L/M (9.5KW) ...	22010310
Flow Regulator 3.5L/M (10.5KW) .	22010410
5. Solenoid Valve Assembly.....	83307110
6. Pressure Relief Device	82800450
7. Trimplate.....	7053138
8. Can Brace.....	7053008
9. Thermostatic Valve Assembly.....	83307130
10. Connecting Tube.....	22010260
11. Scale Trap Cover.....	83307140
12. Thermistor	22010300
13. Microswitch & Wires	P07710904
14. Pressure switch Assembly	83307120
15. Outlet Pipe Assembly	S07711000
– Cover Assembly.....	S07720605

SPARE PARTS

Ref. Description	Part No.
- Wire Set	83307150
- Power PCB Housing	7052991
- Switch cover	7063046
- Inlet Filter	7053009
16. Coloured fascias	
Seaspray	TSTZFSEA
Lilac	TSTZFLIL
Midnight	TSTZFMID
Chrome	P07721007

FAULT FINDING

IMPORTANT: Switch off the electricity at the mains supply and remove the circuit fuse before attempting any fault finding inside the unit.

Problem/Symptom	Cause	Action/Cure
1 Shower inoperable.	1.1 Interrupted power supply.	1.1.1 Blown fuse or circuit breaker. Check supply. Renew or reset fuse or circuit breaker. If it fails again, consult a qualified electrician.
	1.2 Unit malfunction.	1.2.1 Power cut? Check other appliances and if necessary, contact local Electric Supply Co. 1.2.1 Have unit checked by suitably qualified electrician or contact Customer Service.
2 Water flows when isolating switch is switched on.	2.1 Ribbon cable is not connected.	2.1.1 Switch off the electric supply, remove the shower cover and plug in ribbon cable.
	2.2 Unit malfunction.	2.2.1 Contact Customer Service.
3 Water too hot.	3.1 Temperature control incorrect setting.	3.1.1 Turn anti-clockwise.
	3.2 Unit malfunction.	3.2.1 Contact Customer Service.
4 Unstable shower temperature or flow.	4.1 Blockages.	4.1.1 Clean showerhead. Check inlet filter.
	4.2 Loose ribbon cable connection.	4.2.1 Check connections on PCB.
	4.3 Unit malfunction.	4.3.1 Contact Customer Service.
5 Water too cool or cold.	5.1 Temperature control incorrect setting.	5.1.1 Turn clockwise.
	5.2 Unit malfunction.	5.2.1 Contact Customer Service.
	5.3 Safety cut-out operated.	5.3.1 The thermal safety cut-out device has operated. Have unit checked by suitably qualified electrician or contact Customer Service.
6 Low pressure indicator flashing.	6.1 Water pressure has dropped below minimum required.	6.1.1 Wait until water pressure has returned to normal.
	6.2 Blockage in outlet.	6.2.1 Check and clean outlet and/or showerhead.
	6.3 Loose connection on PCB.	6.3.1 Check connection on PCB from pressure switch.

FAULT FINDING

Problem/Symptom	Cause	Action/Cure
6 Low pressure indicator flashing.	6.4 Blocked connecting tube to pressure switch.	6.4.1 Make sure the tube from solenoid valve to pressure switch is not kinked or blocked.
7 Water continues to flow when unit is isolated at isolating switch.	7.1 Debris in solenoid.	7.1.1 Contact Customer Service for advice.
8 Pressure relief device has operated (water ejected from PRD tube).	8.1 Blocked showerhead.	8.1.1 Clean or replace blocked showerhead cartridge and then fit a new PRD.
	8.2 Twisted/blocked flexible shower hose.	8.2.1 Check for free passage through hose. Replace the hose if necessary, then fit new PRD.
	8.3 Showerhead not removed whilst commissioning.	8.3.1 Fit new PRD. Commission unit with showerhead removed.

Note: Identify cause of operation before fitting new PRD unit. When fitting a new PRD, follow the commissioning procedure.

It is advised all electrical maintenance/repairs to the shower should be carried out by a suitably qualified person.

In the unlikely event of unit failure other than detailed in the fault finding page, please contact Customer Service for advice.

WEEE Directive – Policy Statement

As a producer and a supplier of electric showers, Triton Showers is committed to the protection of the environment via our own environmental policy and the compliance with the **WEEE directive**.

Triton Showers is fully registered with the Environment Agency under the following schemes:

Repic: Producers take-back scheme (PTS), registration number WEE/EJ3466QV

Valpak: Distributor take-back scheme (DTS), registration number 9659

All our electric products are labelled accordingly with the crossed out wheeled bin symbol. This indicates, for disposal purposes at end of life, that these products must be taken to a recognised collection points, such as local authority sites/local recycling centres; this will be free of any charges. **Do not return to Triton Showers.**



UK SERVICE POLICY

In the event of a product fault or complaint occurring, the following procedure should be followed:

1. Telephone Customer Service on **02476 378495** having available, your details including post code, the model number and power rating of the product, together with the date of purchase and, where applicable, details of the particular fault.
2. If required, the Customer Service Advisor will arrange for a qualified engineer to call.
3. All products attended to by a Triton service engineer must be installed in full accordance with the Triton installation guide applicable to the product. (Every product pack contains an installation guide, however, they can also be bought via our Customer Service Spares Department).
4. Our engineer will require local parking and if a permit is required this must be available to the engineer on arrival at the call.
5. It is essential that you or an appointed representative (who must be over 18 years of age) is present for the duration of the service engineer's visit. If the product is in guarantee you must produce proof of purchase.
6. Where a call under the terms of guarantee has been booked and the failure is not product related (i.e. scaling and furring, incorrect water pressure, pressure relief device operation or electrical/plumbing installation fault) a charge will be made. A charge will also be issued if nobody is at home when the service engineer calls or adequate parking/permit is not available.
7. If the product is no longer covered by the guarantee an up front fixed fee will be charged before the site visit.
8. Should proof of purchase not be available on an "in-guarantee" call, or should the service engineer find that the product is no longer under guarantee, the engineer will charge the same fixed price and the customer will be expected to pay the engineer before he leaves. If payment is not made on the day an administration charge will be added to the fixed charge.
9. If a debt is outstanding from a previous visit, or from any other Triton purchase, Triton reserves the right to withhold service until the debt has been settled.
10. Triton takes the health, safety and wellbeing of its employees very seriously and expects customers to treat all staff members with respect. Should any employee feel threatened or receive abuse, either verbally or physically, Triton reserves the right to withhold service

Replacement Parts Policy

Availability: It is the policy of the manufacturer to maintain parts availability for the duration of production and a period of five years thereafter, in accordance with industry standards.

Spare parts are available via our website, www.tritonshowers.co.uk, or by telephoning Triton Customer Service Spares Department. Payment should be made by credit/debit card (excluding American Express or Diners Card). Payment can also be made by pre-payment of a pro forma invoice by cheque or money order.

Telephone orders are based on information given during of the call.

Before contacting Triton, please verify your requirements using the information contained in the supplied user guide. Triton cannot accept liability for incorrect part identification.

TRITON STANDARD GUARANTEE

With the exception of accessories, Triton guarantee the product against all manufacturing defects for a period of

2 years (for domestic use only) from the date of purchase, provided that it has been installed by a competent person in full accordance with the fitting instructions.

All accessories such as shower heads, hoses and riser rails carry a **1 year** parts only guarantee against manufacturing defects.

Any part found to be defective during this guarantee period we undertake to repair or replace at our option without charge so long as it has been properly maintained and operated in accordance with the operating instructions, and has not been subject to misuse or damage. This product must not be taken apart, modified or repaired except by a person authorised by Triton. This guarantee applies only to products installed within the United Kingdom and does not apply to products used commercially. This guarantee does not affect your statutory rights.

What is not covered:

1. Breakdown due to: **a)** use other than domestic use by you or your resident family; **b)** wilful act or neglect; **c)** any malfunction resulting from the incorrect use or quality of electricity, gas or water or incorrect setting of controls; **d)** failure to install in accordance with this installation guide
2. Claims for missing parts once the product has been installed.
3. Repair costs for damage caused by foreign objects or substances.
4. Total loss of the product due to non-availability of parts.
5. Compensation for loss of use of the product or consequential loss of any kind.
6. Call out charges where no fault has been found with the appliance.
7. The cost of repair or replacement of pressure relief devices, showerheads, hoses, riser rails and/or wall brackets, isolating switches, electrical cable, fuses and/or circuit breakers or any other accessories installed at the same time.
8. The cost of routine maintenance, adjustments, overhaul modifications or loss or damage arising therefrom, including the cost of repairing damage, breakdown, malfunction caused by corrosion, furring,
9. Call out charges where the water supply cannot be isolated, this includes consequential losses arising from unserviceable supply valves.

For the latest Terms & Conditions, please see:
www.tritonshowers.co.uk

Customer Service: 02476 378495

Trade Installer Hotline: 02476 378344

Fax: 02476 324504

www.tritonshowers.co.uk

E-mail: serviceenquiries@tritonshowers.co.uk

Triton Showers
Triton Road
Nuneaton
Warwickshire CV11 4NR

Triton is a division of Norcross Group (Holdings) Limited

Extended Warranty AVAILABLE NOW. Call 02476 378495 for more details.