

ASPIRANTE

Aspirante ***power shower***



Installation and operating instructions

INSTALLERS PLEASE NOTE THESE
INSTRUCTIONS ARE TO BE LEFT WITH
THE USER



! The showerhead and hose supplied with this product are an integral part of the safety of your shower. Failure to use genuine Triton parts may cause injury and will invalidate your warranty !

CONTENTS	Page
Plumbing and electrical notes.....	1
Introduction	2
Safety warnings	2
Main components	3
Specifications.....	3
Site requirements – water	4
General installation notes	5
Siting of the shower	6
Removing the cover.....	7
Plumbing connections	8
Fitting the shower to the wall.....	10
Electrical connections	12
Commissioning and setup procedure	13
Replacing the cover	15
Temperature control spindle setting	16
Operating the shower.....	17
Adjusting the maximum temperature stop	18
Cleaning.....	19
Instructions for installers and service engineers only	20
Spare parts	21
Fault finding	22 - 23
Water/Cable entry points diagram	24
Guarantee, service policy, etc.	rear cover

⚠ WARNING ⚠

This appliance can be used by children aged from 8 years and above and persons with reduced physical, sensory or mental capabilities or lack of experience or knowledge if they have been given supervision or instruction concerning use of the appliance in a safe way and understand the hazards involved. Children may not play with the appliance. Cleaning and user maintenance shall not be made by children without supervision.

To check the product suitability for commercial and multiple installations, please contact Triton's specification advisory service before installation.

Telephone: 024 7637 2222

Facsimile: 024 7632 4504

E mail: technical@tritonshowers.co.uk

1 PLUMBING NOTES

- 1.1** All installations must comply with Water Regulations or Water Bylaws.
- 1.2** Supply pipes must be flushed to clear debris before connecting the shower unit.
- 1.3** DO NOT connect the shower unit to the mains cold water supply as it would damage the unit and also, the installation would be in breach of Water Regulations.
- 1.4** DO NOT use excessive force when making connections to the flexible hose or showerhead – finger tight is sufficient.
- 1.5** ALL plumbing connections are to be completed and water supplies turned on BEFORE switching on the electricity supply. The shower must not be operated dry without water.
- 1.6** DO NOT solder pipes or fittings within 300 mm of the shower appliance, as heat transfer can damage components.
- 1.7** When installed, the top of the shower unit must be at least 75 mm lower than the base of the cold water storage cistern to prevent the pump being run dry without water.
- 1.8** A dedicated cold water supply must be taken directly from the cold water cistern to the shower. This draw-off must be on the opposite side of the cistern to the float operated valve to reduce the risk of air entering the unit.
- 1.9** The action of the pump is to increase the flow rate. If the supply pipework cannot handle the resulting flow rate then:
 - 1.9.1** The anticipated flow rate may not be achieved.
 - 1.9.2** Air may be drawn into the hot supply from the vent pipe causing spluttering and temperature fluctuations at the showerhead.
- 1.10** Fullway isolating valves MUST be fitted on the hot and cold water supplies to the shower as an independent means of isolating the water supplies should maintenance or servicing be necessary. DO NOT use stop taps or ball-o-fix type valves which restrict flow.

2 ELECTRICAL NOTES

- 2.1** The installation must comply with BS 7671 'Requirements for electrical installations' (IEE wiring regulations). Make sure the incoming hot and cold water supplies to the shower are adequately earth bonded.
- 2.2** DO NOT turn on the electrical supply until the plumbing connections have been completed. Only then can the electricity be switched on in order to power the solenoid to turn water on to the shower when commissioning. The shower must not be operated dry without water.
- 2.3** The mains supply must be 230/240V, at 50Hz, connected to the unit via a double pole switched 3 Amp fused connection unit (not supplied) with a minimum 3 mm contact separation gap in each pole.
- 2.4** In accordance with 'The Plugs and Sockets etc. (Safety) Regulations 1994', this unit is intended to be permanently connected to the fixed electrical wiring of the mains system.
- 2.5** Fuses do not give personal protection against electric shock.
- 2.6** A 30mA residual current device (RCD) MUST be installed. This may be part of the consumer unit or a separate unit.

INTRODUCTION

This book contains all the necessary fitting and operating instructions for your Aspirante thermostatic power shower. Please read them carefully.

The shower installation must be carried out by suitably competent person and in sequence of this instruction book.

Care taken during the installation will ensure a long and trouble free life from your shower

IMPORTANT: All plumbing connections must be completed BEFORE making the electrical connections.

Please read through the whole of this book before beginning your installation.

IMPORTANT: The fittings on the pipe inlet elbows are of the push-in type. The pipework must be cut with a pipe cutter and all burrs and rough edges removed from the end of the tube. The fittings can be used with copper and plastic pipe.

Where chrome plated pipe is used, remove the first 25 mm of plating.

Note: The pump inside this product is rated 15 minutes on/45 minutes off duty cycle.

SAFETY WARNINGS

1. Do not insert fingers into the push-in inlet fittings. Doing so could cause injury.
2. **Under no circumstances must this product be connected to mains cold or hot water supplies.** Failure to comply will invalidate the guarantee.
3. The shower MUST NOT be used if suspected of being frozen.
4. The outlet of this appliance must not be connected to any form of tap or fitting not recommended by the manufacturer.
5. The showerhead cartridge must be cleaned regularly to remove scale and debris.
6. This appliance must be earthed.
7. Switch off immediately at the isolating switch if water ceases to flow during use.
8. If it is intended to operate the shower outside the guidelines laid out in the site requirements, see NOTE below.

Note: In the event of items 3, 7 and 8, contact Customer Service for advice.

Replacement parts can be ordered from Triton Customer Service. See 'spare parts' for details and part numbers.

A 30mA residual current device (RCD) MUST be installed in all UK 230V electric and pumped shower circuits. This may be part of the consumer unit or a separate unit.

MAIN COMPONENTS

1. Top pipe entry and cable entry
2. Terminal block
3. Cover screw fixing
4. Motor retaining bracket
5. Rear pipe entry and cable entry
6. Wall fixing holes
7. Pipe inlet elbow – top (contains single check valves)
8. Filter cover – top
9. Pump
10. PCB housing
11. Setting adaptor
12. Temperature control valve
13. Solenoid
14. Filter cover - bottom
15. Pipe inlet elbow – bottom (contains single check valves)
16. Outlet
17. Bottom pipe entry

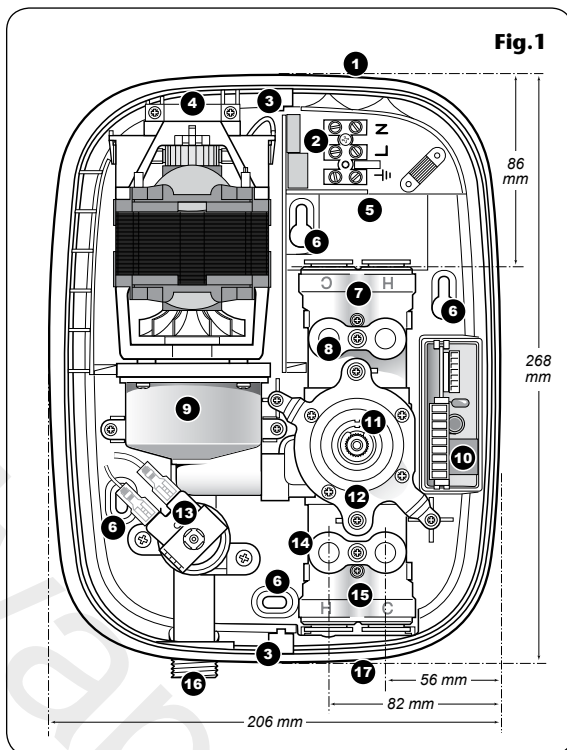

SPECIFICATIONS

Hot water temperature

Maximum temperature 65°C.

BS 6700 recommends that the temperature of stored water should never exceed 65°C. A stored water temperature of 60°C is considered sufficient to meet all normal requirements and will minimise the affects of scale in hard water areas.

Temperature control

To obtain the maximum performance, this unit should be installed, operated and maintained as instructed in this book. The full performance specification as below for the standard unit is achieved with a blend set between 35°C – 40°C and supplies of 15°C cold and 65°C hot with nominally equal pressures.

- 1) The blended water temperature is maintained within 2°C with a 10°C change in the hot and cold water supply.

- 2) The sensor effects a shut down to seepage in approximately 2 seconds if the cold supply fails.
- 3) Shut down to seepage is achieved even if the hot supply is only 12°C above the blend temperature.
- 4) The blended water temperature is maintained within 1°C when the pressure between inlet and outlet is halved (defined as a pressure loss ratio of 2:1) on either the hot or cold side.

Maximum static inlet pressures

100 Kpa (1 bar) or 10m (supplies must be gravity fed at nominally equal pressures).

Minimum static inlet pressure

0.75 Kpa (0.0075 bar) or 75mm (required to prime the integral centrifugal pump).

Maximum supply head 10m.

SITE REQUIREMENTS

Water

The installation must be in accordance with Water Regulations.

For correct operation of this shower unit, both hot and cold water supplies to the appliance must be gravity fed, at nominally equal pressures, from a cold water storage cistern and a hot water storage cylinder.

The water circuit should be installed so that the flow is not significantly affected by other taps and appliances being operated elsewhere on the premises.

Fig.2 shows a recommended installation where the hot water supply for the shower is made via a tee connection on the underside of the rising horizontal section of pipework from the cylinder. Alternatively, the connection can be taken from the hot supply pipe to other outlets as long as it is the first draw-off below the ventilation pipe tee.

Fig.3 illustrates all the incorrect connections that must be avoided.

All pipework to the shower unit must be routed where it remains below the level of water in the cistern. In the case of horizontal sections of pipework in lofts, it may be necessary to fit automatic air vents at high points on the supplies to remove the possibility of air locks.

For the operation of the shower only, it is recommended that the cold water storage cistern is capable of holding at least 114 litres (25 gallons). Where other hot and cold outlets are likely to be in use simultaneously, the storage capacity should be increased to 228 litres (50 gallons) in accordance with BS 6700.

Do check compliance with all the local Water Regulations/Bylaws.

DO NOT connect to a combination cylinder unless there is a guaranteed 114 litre cold supply to the cylinder as the shower can deliver up to 14 litres per minute. It is advisable to check that

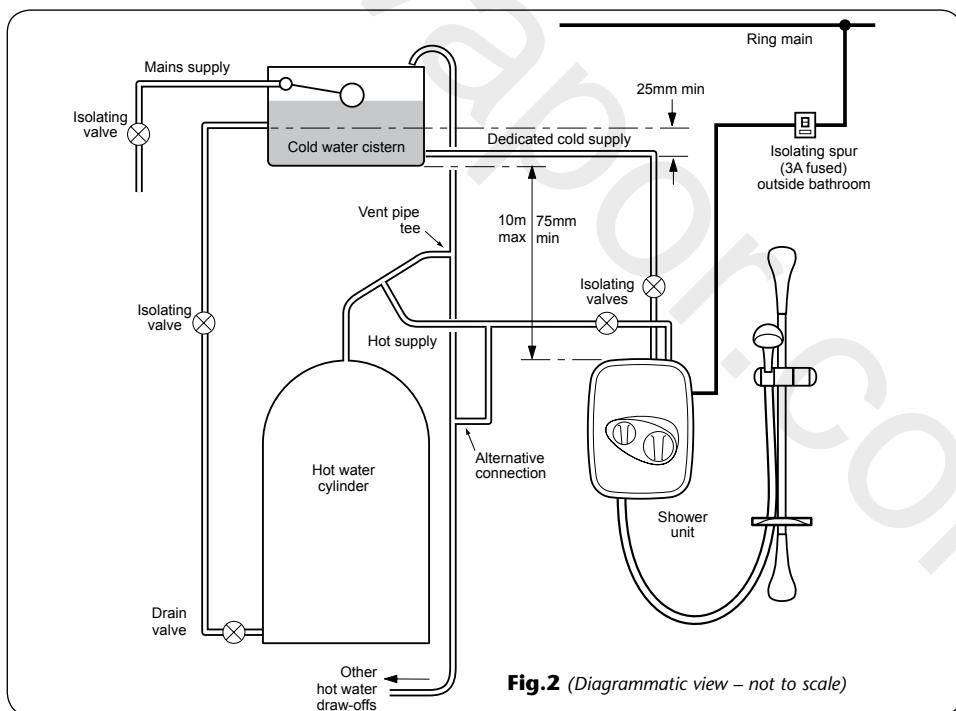

Aspirante thermostatic power shower

the infill rate from the float operated valve meets the output requirements.

It is recommended that there is a minimum of approximately 114 litres (25 gallons) of hot water storage per appliance.

The shower MUST NOT be connected to the mains cold water supply.

DO NOT use jointing compounds.

GENERAL INSTALLATION NOTES

1. DO NOT take risks with plumbing or electrical equipment.
2. DO NOT install this unit in a position where it could become frozen.
3. Isolate electrical and water supplies BEFORE proceeding with installation work.
4. Shower control MUST be fed from a cold water storage cistern and hot water cylinder that provides nominally equal pressures.

5. The unit must be mounted onto the finished wall surface (on top of tiles). DO NOT tile up to the unit after fixing to the wall.
6. If installing with rear inlet supplies, it is recommended the supply pipework is sealed to the wall to prevent water from leaking back into the wall.
7. In solid wall installations, the supply pipework should be housed within ducting in order to allow some free lateral movement when making connections and to make sure of compliance with the requirements of Water Regulations (accessibility of pipes and pipe fittings).

Fig.4 shows a schematic wiring diagram of the unit.

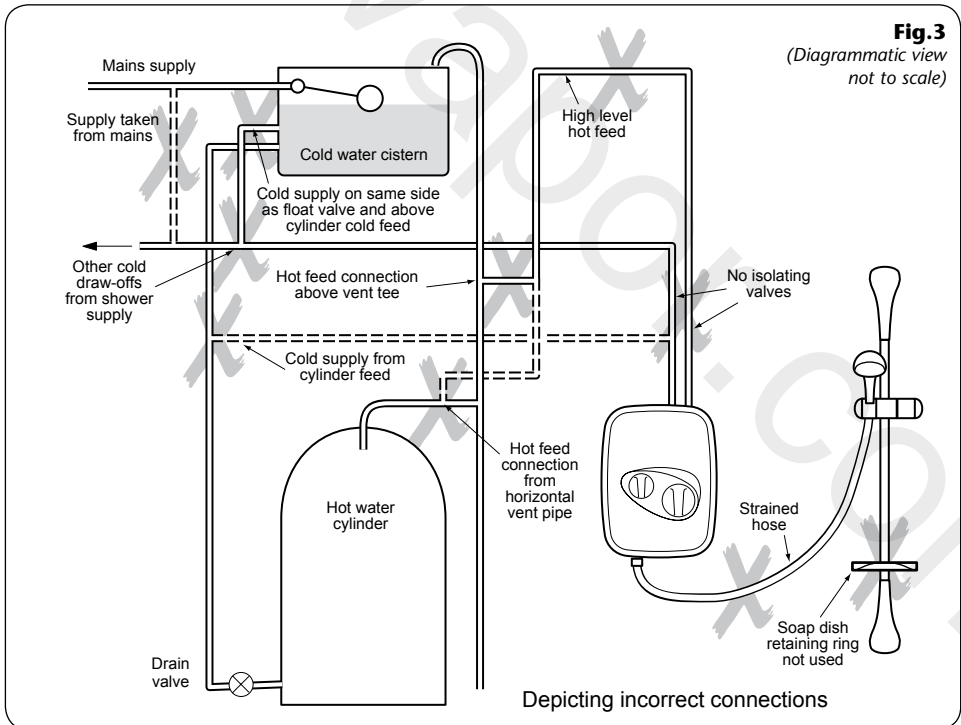
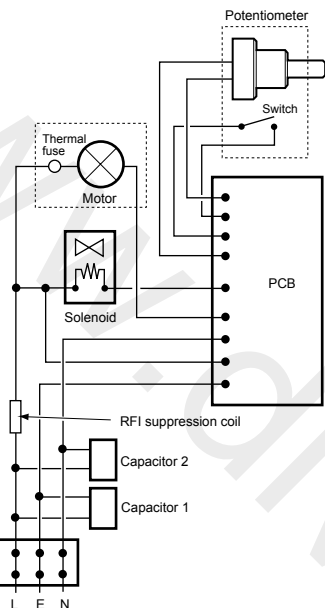

Fig.4 (schematic view)



SITING OF THE SHOWER

WARNING!

The shower must not be positioned where it will be subjected to freezing conditions.

FOR EASE OF SERVICING, THE APPLIANCE MUST ALWAYS BE MOUNTED ON THE SURFACE OF TILED WALLS. NEVER TILE UP TO THE APPLIANCE.

Refer to **fig.5** for correct siting of the shower. Position the appliance vertically where it will NOT be in direct contact with water from the showerhead.

Note: Allow enough room between the ceiling and the shower unit to access the top cover screw.

Position the shower and showerhead on the wall so that all controls are comfortably reached while using the shower.

The showerhead and riser rail can be positioned either side of the shower unit.

Note: Water Regulations require the showerhead be 'constrained by a fixed or sliding attachment so that it can only discharge water at a point not less than 25 mm above the spill-over level of the relevant bath, shower tray or other fixed appliance'.

Fig.5

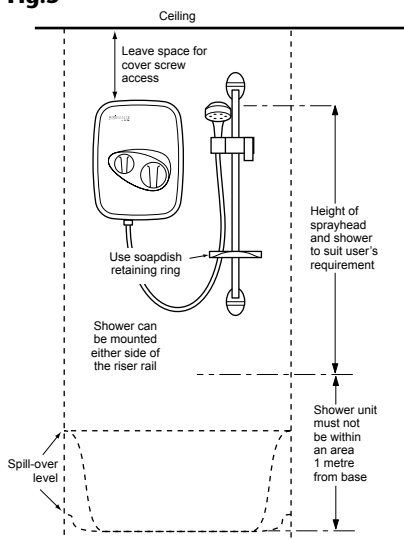

REMOVING THE COVER

Note: When you first receive your Aspirante power shower, the temperature control knob and cover fixing screws will be packaged separately within the box. In this instance just carefully remove the cover and proceed to 'Plumbing connections' below.

To remove the cover, first pull off the temperature control only (**fig.6**) – not the flow control.

This will reveal the maximum temperature stop (**fig.7**). This should be left in position.

Note: If adjustment of the maximum temperature stop is required, refer to section 'Adjusting the maximum temperature stop'.

Remove the two cover fixing screws – top and bottom (**fig.8**).

Carefully lift the cover away from the backplate. Lay aside the cover and screws until the unit is fully installed.

Note: When removing the cover for future maintenance purposes etc. be aware of the lead connected to the PCB unit. Carefully pull off the lead from the PCB.

DO NOT let the cover dangle by the lead.

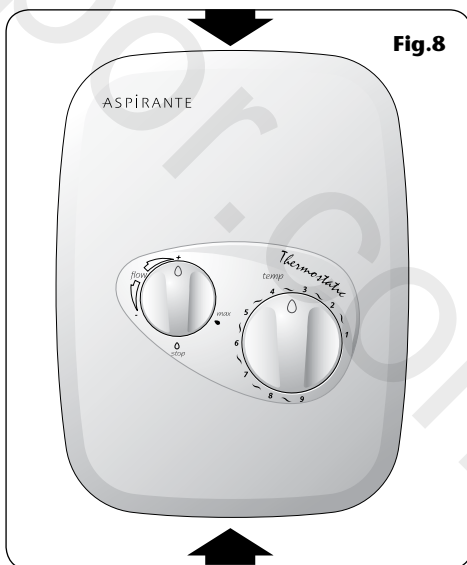
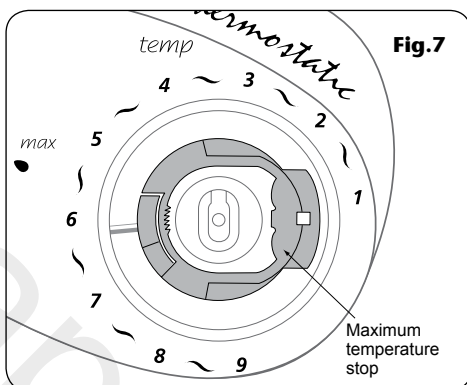
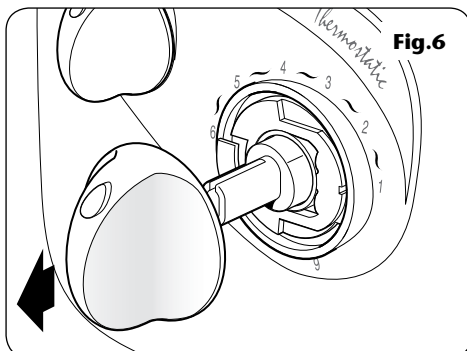
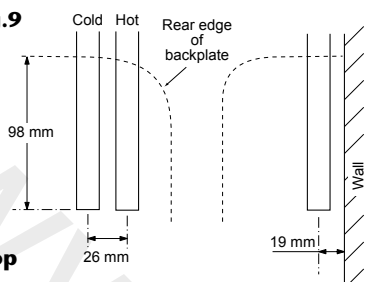
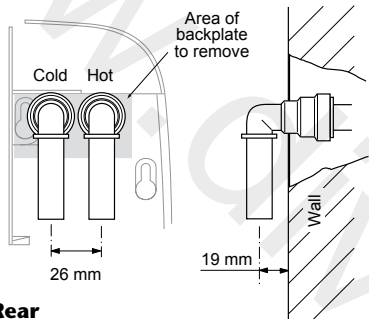

Fig.9



Top



Rear

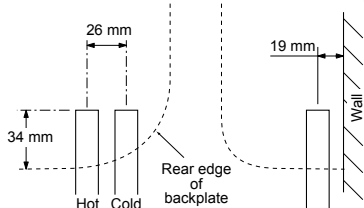

Bottom

Fig.10

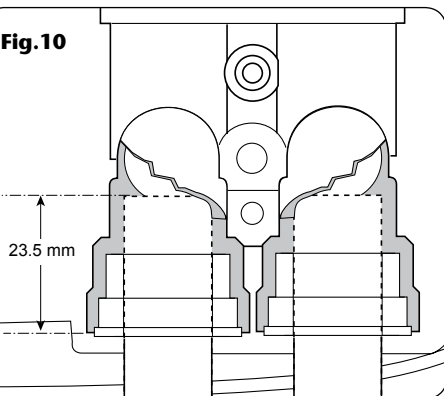

PLUMBING CONNECTIONS

Plumbing to be completed before wiring

Note: The outlet of the shower must not be connected to any tap or fitting not recommended by Triton Plc.

DO NOT use jointing compounds on any pipe fittings for the installation.

When connecting pipework avoid using tight 90° elbows. Swept or formed bends will guarantee optimum performance.

Isolate the mains water supply to the cold water cistern. Drain the hot and cold pipes by opening all taps.

The hot water supply can be taken from the hot supply pipe from the cylinder, checking that it is the first draw-off below the ventilation pipe tee in order to minimise the effects of water draw-off elsewhere in the house (see **fig.2**).

Note: There must not be any other draw-offs between the take-off point and the shower.

A dedicated cold water supply must be taken directly from the cold water cistern to the shower. This draw-off must be positioned 25 mm below the cold feed connection to the hot water cylinder on the opposite side of the cistern to the float operated valve (see **fig.2**). This minimises air ingress into the pipework.

Plumbing options other than those outlined in these fitting instructions could impair the performance. For example, if hot and cold connections are made after draw-off points to other outlets, (eg. washing machine, taps, etc.) it could result in unstable flows and temperatures should other appliances operate at the same time.

Run the hot and cold pipework to the shower position making sure that the pipework does not rise above the level of water in the cold cistern at any point to avoid air locks. Under normal site conditions 15 mm pipework will be adequate.

Decide the position of the shower. Cut the pipework to the dimensions relevant to the chosen direction of water entry into the shower.

IMPORTANT: For rear entry only, the supplied elbows must be used. For ease of installation, the backplate area adjacent to the top pipe

inlet must be cut out, including the top left wall fixing hole.

When fitting the elbows to incoming pipework, check that the elbow collets are fully engaged with the pipe.

Dimensions are shown in **fig.9** and **fig.10**.

Note: The pipe inlets are marked for hot and cold connections – left side for hot inlet on bottom entry (**fig.11**), but right side for hot inlet on top or rear entry (**fig.12**).

IMPORTANT: The fittings on the inlet elbows are the push-in type. The pipework must be cut with a pipe cutter and all burrs and rough edges removed from the end of the tube. The fittings can be used with copper and plastic pipe.

If using chrome plated copper pipe, remove the first 25 mm of plating completely from the connecting surfaces. If not completely removed then the collet will not grip the pipe and under pressure the pipe may be forced out.

Note: Pipework must be clipped or fixed to the wall so that it cannot be moved or removed without the aid of a tool.

Note: The pipe inlets contain filters. These should be periodically removed and cleaned in order to maintain the performance of the shower. See section 'cleaning' on how to access the filters.

Two factory fitted blanking plugs are fitted to the top pipe inlets. These should be left in position if bottom pipe entry is required. But for top or rear pipe entry, the two plugs must be removed and refitted into the bottom pipe inlets.

Insert the pipe removal tool supplied between the flange of the plug and the grey collet and lever the plug outward (**fig.13**). While holding back on the collet, pull out each plug by hand. When refitting the plugs in the bottom pipe inlets, make sure that they are pushed fully home.

IMPORTANT: The inlets contain check valves, so before completing the connection of the water supplies to the shower flush out the pipework to remove all swarf and system debris that may cause damage to internal parts. This can be achieved by connecting a hose to the pipework and turning on the water supplies long enough to clear the debris to waste.

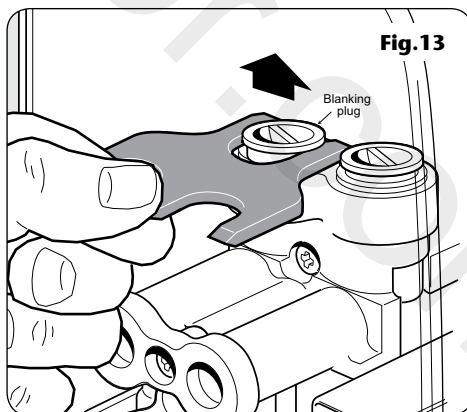
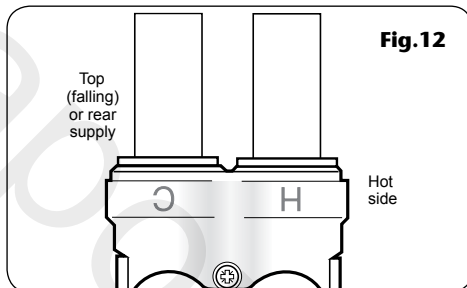
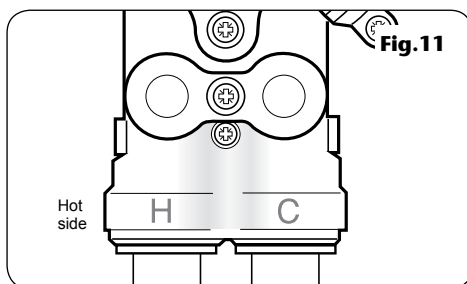
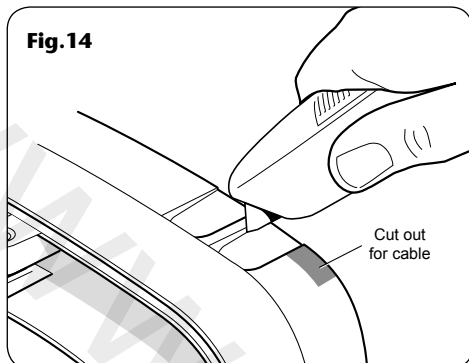

Fig.14



FITTING THE SHOWER TO THE WALL

IMPORTANT: Prior to fitting the shower, make sure that the plumbing is flushed out, removing all debris, flux, etc.

For top pipe entry or top cable entry, remove the relevant cut-outs by either breaking out or by using a knife or junior hack saw (**fig.14**).

If top entry for both pipe and cable is required, then additionally remove the shaded area (**fig.14**) by using a knife or junior hacksaw.

For bottom pipe entry, remove the cut-out and break off the two circular parts (**fig.15**). Replace the cut-out.

Fig.15

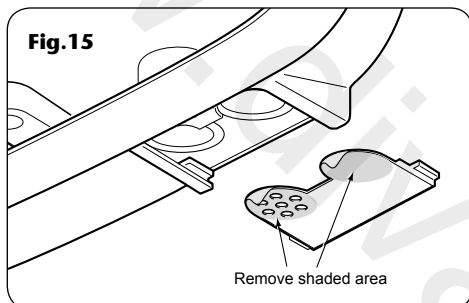

For rear pipe entry only, the supplied elbows must be used with the necessary portion of backplate cut away as shown in **fig.9**.

If rear cable entry is required, conduit or other routing of the electrical cable must be completed before fixing the shower to the wall.

Offer the backplate unit up to the completed pipework and manoeuvre so that the end of the pipes enter fully into the inlet fittings.

Mark positions for wall fixing holes using backplate as template (**fig.16**). Note that four fixing holes are provided but using only two should be adequate for most site conditions.

Using the pipe removal tool supplied, push back and hold the collets from the pipework (**fig.17**) in order to disengage pipework from the inlet elbows.

Remove unit from the wall.

IMPORTANT: Before fitting the shower to the wall check that the safety earth contact spring has not been damaged. If the spring has been damaged then **DO NOT** fit the shower and return the appliance for replacement.

Drill and plug the wall.

(An appropriate drill bit should be used. If the wall is brick, plasterboard or a soft building block, appropriate wall plugs and screws should be fitted).

Fig.16

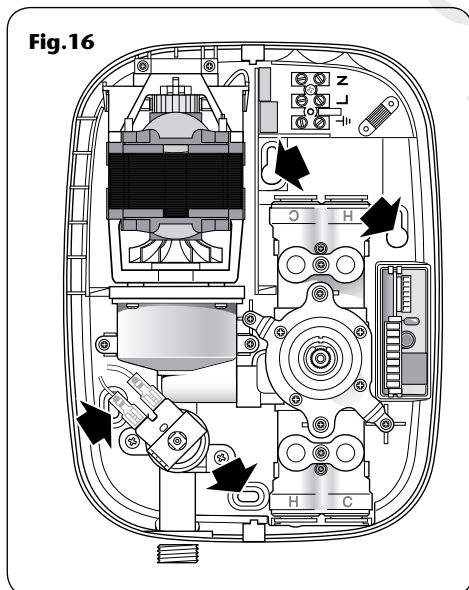

Note: If fitting rising supplies to the unit, make sure that debris does not enter the pipes when drilling the wall.

Offer the back plate unit up to the completed pipework and manoeuvre so that the end of the pipes enter fully into the inlet fittings. Check the backplate is square and the fixing holes are aligned and secure to the wall (**fig.16**).

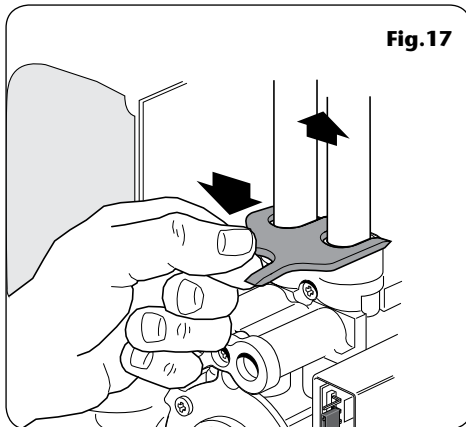
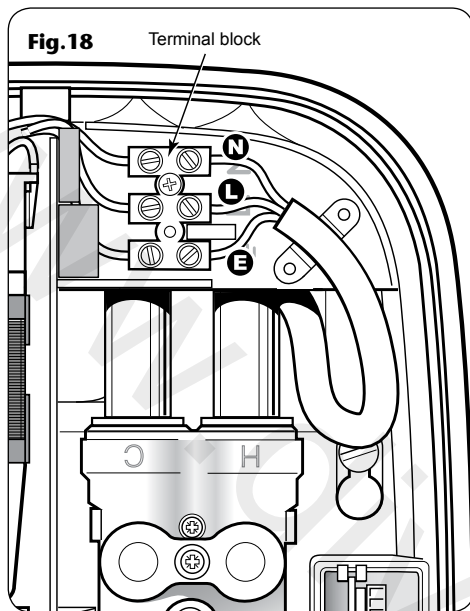

Fig.17



IMPORTANT: The earth continuity to the cover of the shower must be checked and approved, by a qualified electrician when the shower is installed, and at least every 2 years thereafter.

ELECTRICAL CONNECTIONS

WARNING!
THIS APPLIANCE MUST BE EARTHED

The supply cable must conform to relevant tables in current IEE regulations. In most cases 1 mm² twin and earth will be adequate.

The electrical rating of the shower is on the rating label within the unit.

Cable entry points are shown in **fig.1**. Conduit entry can only be from the rear.

Route the cable into the shower, taking care to avoid the area of the wall fixings and connect to the terminal block (**fig.18**) as follows:

Live cable to terminal marked **L**

Neutral cable to terminal marked **N**

Earth cable to terminal marked **E**

IMPORTANT: Fully tighten the terminal block screws and check that no cable insulation is trapped under the screws.

Note: The supply cable earth conductor must be sleeved.

The earth continuity conductor of the electrical installation must be effectively connected electrically to all exposed metal parts of other appliances and services in the room in which the shower is to be installed, to conform to current IEE regulations.

Note: Fuses do not guarantee user protection against electric shock. In the interest of electrical safety, all mains electric and pumped showers should be fitted with a 30mA residual current device (RCD). This may be part of the consumer unit or a separate unit.

DO NOT switch on the electricity supply until the water has been turned on to the unit and connections have been tested for leaks.

COMMISSIONING

WARNING!

Before normal operation of the shower, it is essential that the commissioning and setup procedure are correctly completed. Failure to do so could cause the pump to run dry without water and invalidate your guarantee.

THE COVER MAY BE LEFT OFF INITIALLY ONLY FOR COMMISSIONING.

The first operation of the shower is intended to flush out any remaining system debris and to make sure that water is purged through the unit. This operation must be carried out with the flexible hose screwed to the shower outlet but without the showerhead attached.

Direct the outlet of the flexible hose to waste. Check that the gate valves controlling the water supply to the unit are fully open. (There is no need to fit cover at this stage but be aware of live parts when the electricity is switched on temporarily).

Fit the temperature control onto the adaptor (**fig.19**). This is a push fit and will only fit one way.

On the PCB, make sure the commissioning link is positioned on the middle two pins (**fig.20**).

Switch on electric supply at isolating switch.

WARNING!

Be aware of live parts in the unit when the electricity is switched on. DO NOT tamper with any parts and DO NOT deviate from the following instructions.

Water will begin to flow under gravity pressure. In order to dispel air and to prime both supplies to the shower unit, turn the temperature control several times within its rotational limits.

ONCE RESISTANCE IS FELT, DO NOT FORCE THE CONTROL FURTHER.

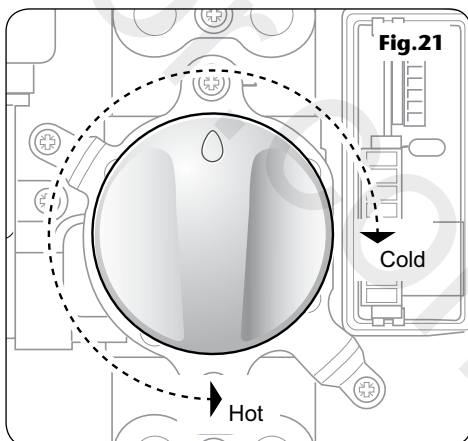
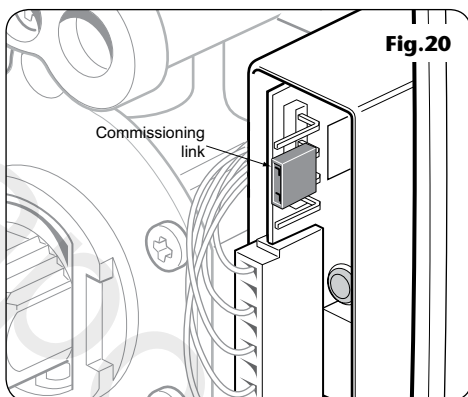
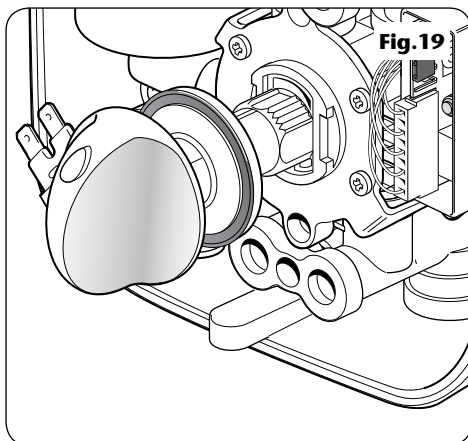

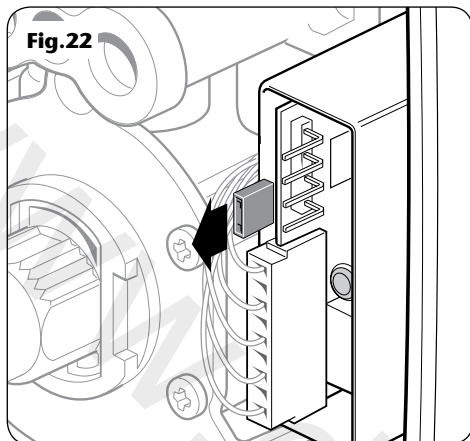

Note: The temperature control rotates less than one complete turn (**fig.21**) – from 3 o’ clock (cold) anti-clockwise to 6 o’ clock position (hot) and visa versa. DO NOT force it beyond these limits.

To stop the water flow, switch off the electricity supply at the isolating switch.

Check for leaks in the pipework and remedy if necessary. If rear entry has been used then seal around pipes with mastic to prevent the possibility of water entering the wall cavity. DO NOT use plaster as this could cause difficulty if maintenance is required at a later date.

Setup Procedure

CHECK THE ELECTRICITY TO THE UNIT IS SWITCHED OFF.

Pull off the temperature control knob.

Remove the commissioning link from the PCB (**fig.22**) and store safely for future use.

Offer the cover to the unit. Attached to the flow control potentiometer inside the cover is a 4-wire lead. Fit the connector on the end of this lead to the 4 pins on the PCB (**fig.23**) – it can fit either way.

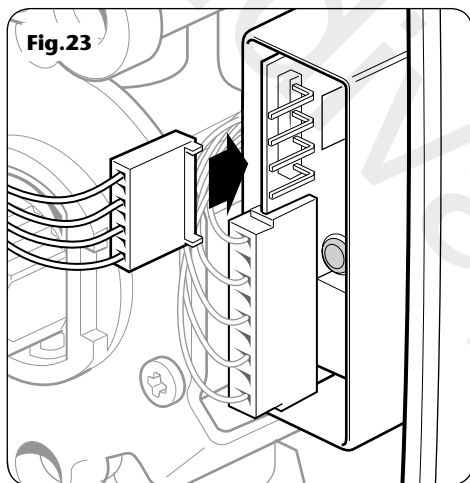

REPLACING THE COVER

IMPORTANT: Make sure that the earth contact spring within the unit is not distorted before replacing the cover.

Fit the cover, making sure the connector is fitted to the PCB and the wires are clear of the setting adaptor. Secure with the top and bottom fixing screws (**fig.24**). Make sure the maximum temperature stop is still in position.

Note: If adjustment of the maximum temperature stop is required, refer to section 'Adjusting the maximum temperature stop'.

Replace the temperature control knob by push fitting onto the adaptor shaft, noting that it will only fit one way.

Check that the flow control is positioned at 'stop' (**fig.25**).

Switch the electricity supply back on at the isolating switch. Check that both water supplies are still turned on.

Once the installation of the riser rail is complete, the shower is ready for normal operation.



Fig.24

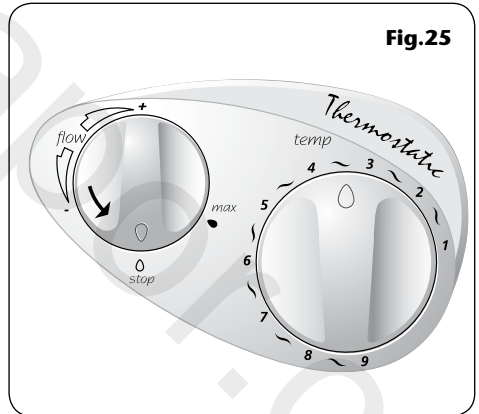

Fig.25



WARNING

COVER RETAINING SCREWS

ONLY the **SUPPLIED SCREWS** should be used. The use of none supplied screws **WILL** invalidate product specifications & warranty.

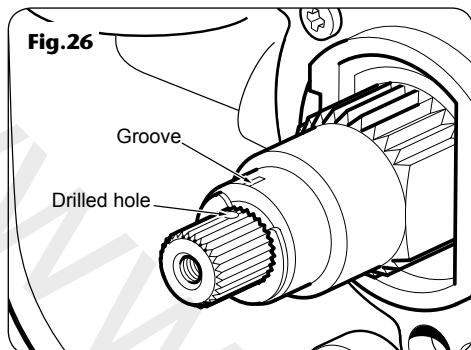

TEMPERATURE CONTROL SPINDLE SETTING

Occasionally the spindle may need adjusting when the temperature control and cover are removed from the unit. To reset the spindle to its correct alignment, please refer to the following:

With the cover and control knob removed, use your fingers to adjust the splined spindle until the small alignment hole drilled into the spindle lines up with the groove in the top of the valve spindle housing (**fig.26**).

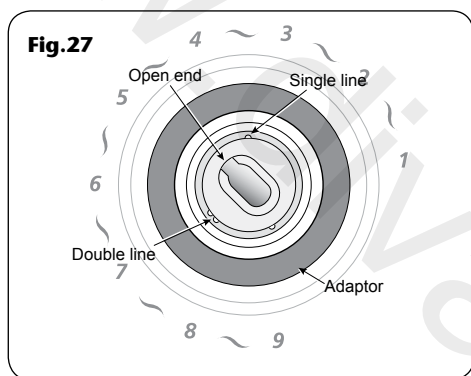

Refit the setting adaptor onto the brass splined spindle aligning the single line on the adaptor with both the black spindle mark and the housing groove (the 'double line' will be at the 8 o'clock position). The temperature control location 'open end' must relate to '5' on the temperature scale when the cover is fitted (**fig.27**).

Note: Incorrect positioning will result in excessive cold bleed.

OPERATING THE SHOWER

Make sure all plumbing and electrical supplies are connected and switched on.

To start the shower, rotate the flow control clockwise from the 'stop' position (**fig.28**). Adjust the control until the flow rate is satisfactory.

For maximum flow, turn the flow control fully clockwise to the 'max' position.

To adjust the temperature, rotate the control (**fig.29**). The temperature is numbered for ease of use. The temperature ranges from '1' – fully cold to '9' – fully hot.

Once the preferred temperature is reached, no further adjustment is required, providing the hot and cold water supplies remain constant.

To stop the shower, return the flow control to the 'stop' position by rotating anti-clockwise (**fig.30**). This stops the pump and water flow.

Unless the shower is to be used again immediately, the shower should also be switched off at the electricity isolating switch.

As a safety feature, the temperature control has a built-in stop to prevent you accidentally exceeding your highest desired temperature. If adjustment is required see section 'Adjusting the maximum temperature stop'.

To override this stop, depress the button (**fig.31**) while the control is up against the stop and turn the control anti-clockwise to the higher settings (pressing the button before the stop will not operate the override mechanism even if the control is turned with the button depressed).

To return to the normal temperature range turn the temperature control clockwise until it is past the maximum temperature stop. Make sure that the temperature control is in the normal temperature range when the shower is switched off. The stop comes in a factory set position based on 65°C stored hot water temperature.

Note: As the flow control is adjusted it is quite normal for the sound of the pump to alter in pitch.

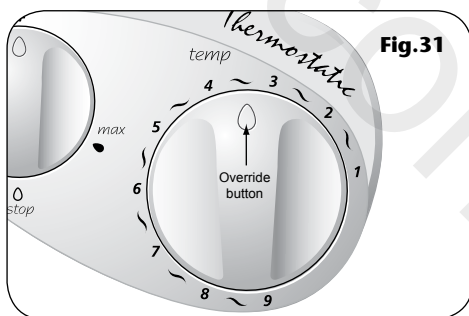
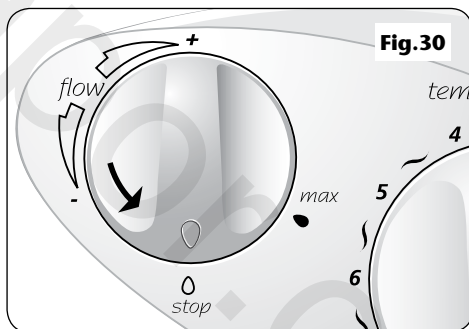
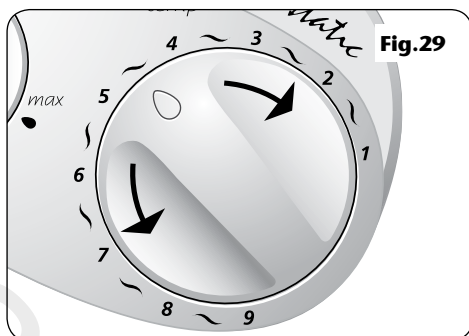
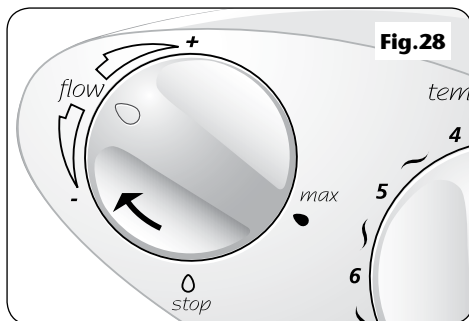

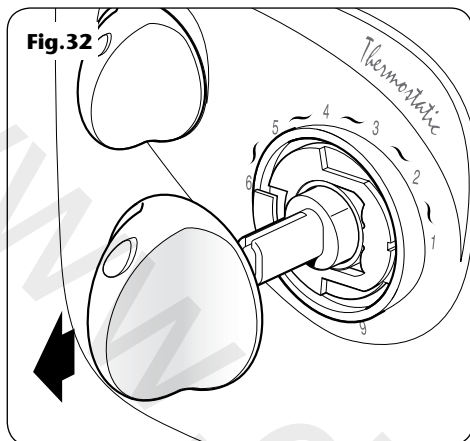

ADJUSTING THE MAXIMUM TEMPERATURE STOP

As a safety feature the shower has a built-in maximum temperature stop to prevent you accidentally exceeding your highest desired temperature. This is set in the factory to provide a maximum temperature based on the hot and cold water supplies being 65°C and 15°C respectively.

Procedure:

Pull off the temperature control (**fig.32**).

Carefully pull off the maximum temperature stop mechanism.

To increase the temperature stop setting, reposition the mechanism anti-clockwise within the arc of the grooves (**fig.33**).

To decrease the temperature stop setting, reposition the mechanism clockwise within the arc of the grooves (**fig.33**).

Replace the temperature control by push fitting onto the adaptor shaft, noting that it will only fit one way.

IMPORTANT: Only adjust the maximum temperature stop when the hot water is at its usual storage temperature.

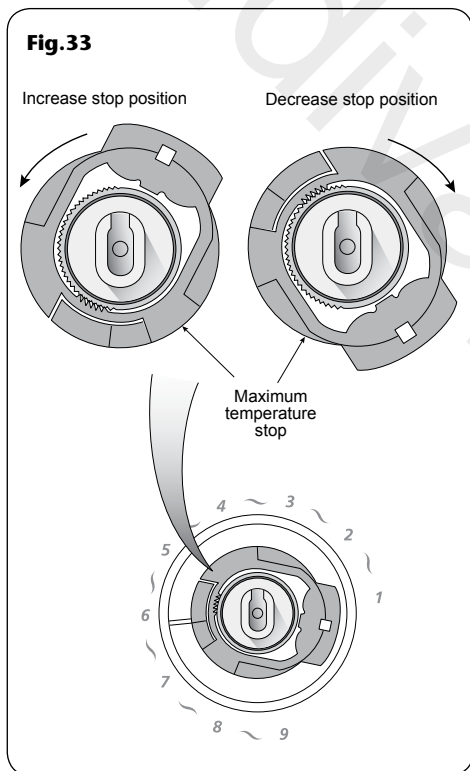

CLEANING

Before cleaning, turn off the unit at the isolation switch to avoid the shower being accidentally switched on.

Triton recommends that all products are cleaned using warm, soapy water.

DO NOT use abrasive or aggressive chemical cleaning products as this may affect the product surface finish and invalidate your guarantee.

IT IS IMPORTANT TO KEEP THE SHOWERHEAD CLEAN TO MAINTAIN THE PERFORMANCE OF THE SHOWER. The hardness of the water will determine the frequency of cleaning. For example, if the shower is used every day in a very hard water area, it may be necessary to clean the showerhead on a weekly basis.

Before replacing the showerhead on the hose, it is advisable to direct the hose to waste, turn the temperature control fully anti-clockwise and press the COLD button. This operation will flush out any loose scale deposits in the unit. Stop after about thirty seconds and replace the showerhead.

WARNING!

DO NOT use abrasive or aggressive cleaning products when cleaning the shower as they may damage the unit.

INSTRUCTIONS FOR INSTALLERS AND SERVICE ENGINEERS

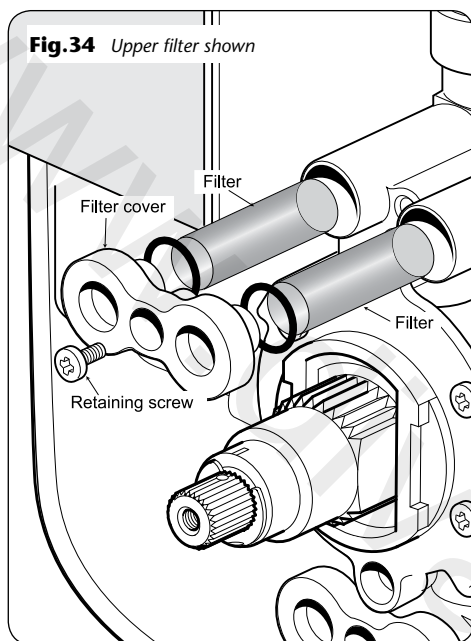

CLEANING THE FILTERS

Note: Isolate the electricity and both hot and cold water supplies to the unit before proceeding further.

Remove the shower unit cover by first pulling off the temperature control and then remove the two fixing screws – top and bottom.

Note: Be aware of the lead connected to the PCB unit. Carefully pull off the lead from the PCB. **DO NOT** let the cover dangle by the lead.

Remove the single retaining screw from either the upper or lower filter cover (fig.34), depending upon whether top/rear entry or bottom entry is used.

Pull off the filter cover.

Carefully hook out the filters together with 'O' rings. Thoroughly clean and replace ensuring the 'O' rings are in position.

Refit the filter cover and secure with the screw.

Offer the cover to the unit and replace the four wire lead to the PCB. Secure the cover with the top and bottom fixing screws. Replace the temperature control.

WARNING!

Switch off the electricity supply and turn off both hot and cold water supplies to the unit before proceeding further.

SPARE PARTS

Ref.	Description	Part No.
1.	Terminal block	22001320
2.	Plastic inlet elbow plug x1	7052140
3.	Pump & motor assembly.....	84000130
4.	Commissioning link.....	22009060
5.	PCB unit.....	7073738
6.	Temperature valve..... 83305270 (thermostatic)	
7.	Solenoid assembly.....	22012190
8.	Filter (pair)	83305330
9.	Cover – thermostatic..... 81700050 (c/w selector knob & potentiometer)	
10.	Setting adaptor..... 7052154	
-	Pipe inlet elbow	83305320 (c/w filters & check valves)
-	Temperature control	83300220 (c/w override button)
-	Maximum temperature stop ...	7052186
-	Pipe removing tool.....	7052144
-	Pipe trim	7052674
-	Wire kit	83311260
-	Rear entry elbow.....	22012890

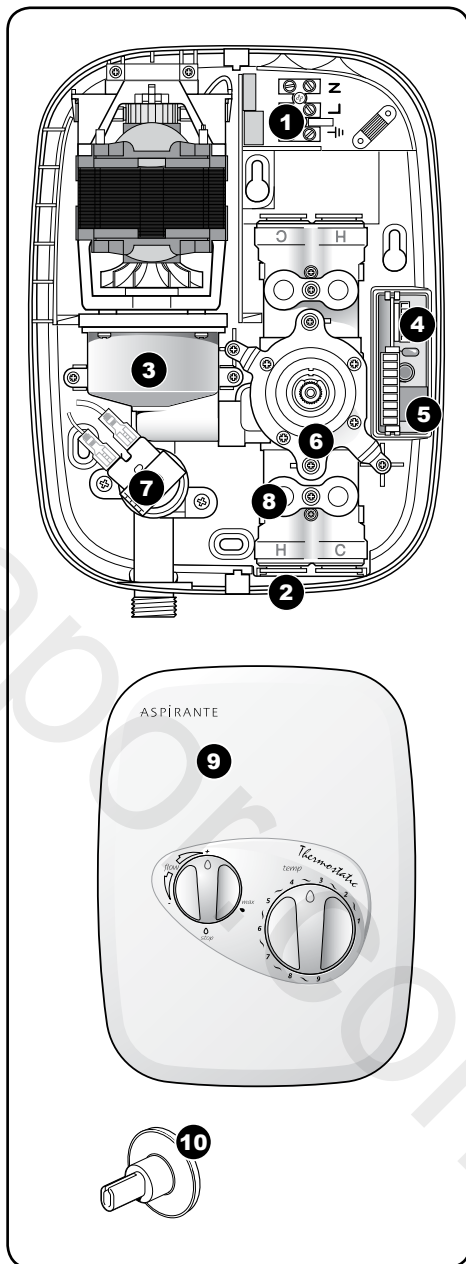

FAULT FINDING

Symptom	Cause	Action/Cure
1 Water too hot.	1.1 Not enough cold water flowing through shower.	1.1.1 Turn the temperature control clockwise.
	1.2 Increase in the ambient cold water temperature.	1.2.1 Turn the temperature control clockwise.
	1.3 Cold inlet filter blocked or check valve sticking.	1.3.1 Remove filter and clean. If problem is with check valve, contact Customer Service.
	1.4 Cold water supply blocked or cut off.	1.4.1 Isolate the shower and consult a competent plumber or contact Customer Service.
2 Water too cold.	2.1 Not enough hot water flowing through shower.	2.1.1 Turn temperature control anti-clockwise.
	2.2 Decrease in ambient cold water temperature.	2.2.1 Turn temperature control anti-clockwise.
	2.3 No hot water in the storage cylinder.	2.3.1 Turn off the shower and wait for hot water cylinder to reheat.
	2.4 Hot inlet filter blocked or check valve sticking.	2.4.1 Remove filter and clean. If problem is with check valve, contact Customer Service.
	2.5 Hot water supply blocked or otherwise cut off.	2.5.1 Turn off the shower. Consult a competent plumber or contact Customer Service.
3 Pump does not operate.	3.1 Interrupted power supply.	3.1.1 Blown fuse. Check supply. Renew fuse. If it fails again consult a competent electrician. 3.1.2 Power cut. Check other appliances and if necessary, contact local Electricity Supply Company.
	3.2 Electrical malfunction.	3.2.1 Consult a competent electrician or contact Customer Service.
	3.3 Motor overheated.	3.3.1 Thermal protection on motor has operated. Allow appliance to cool and reset itself. If it persists, contact Customer Service.

FAULT FINDING (continued)

Symptom	Cause	Action/Cure
4 Water does not flow or is reduced.	4.1 Water supplies cut off.	4.1.1 Check water elsewhere in house and if necessary contact the local Water Company.
	4.2 Shower blocked or air in the system.	4.2.1 Switch off shower and contact Customer Service.
	4.3 Showerhead blocked.	4.3.1 Clean showerhead.
	4.4 Blocked filters.	4.4.1 Clean filters.
5 Cross flow of hot and cold water into system.	5.1 Dirt/debris in check valves.	5.1.1 Isolate water to unit. Remove check valves. Clean and replace.
6 Water dripping from showerhead when turned off.	6.1 Debris in solenoid valve.	6.1.1 Call Customer Service.
	6.2 Potentiometer faulty.	6.2.1 Call Customer Service.

It is advised all electrical maintenance/repairs to the shower should be carried out by a suitably qualified person.

In the unlikely event of a fault occurring please contact Triton Customer Service. Do not remove the shower from the installation.

Entry Points

Diagram Key:



Water Entry Points

Right: bottom, back, top.



Cable Entry Points

Right: back, top.

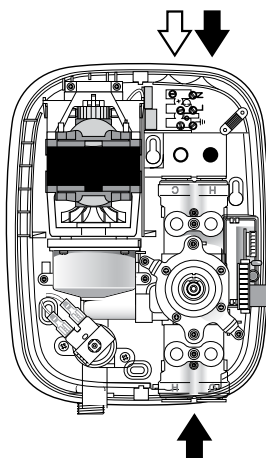

WEEE Directive – Policy Statement

As a producer and a supplier of electric showers, Triton Showers is committed to the protection of the environment via our own environmental policy and the compliance with the **WEEE directive**.

Triton Showers is fully registered with the Environment Agency under the following schemes:

Repic: Producers take-back scheme (PTS), registration number WEE/EJ3466QV

Valpak: Distributor take-back scheme (DTS), registration number 9659

All our electric products are labelled accordingly with the crossed out wheeled bin symbol. This indicates, for disposal purposes at end of life, that these products must be taken to a recognised collection points, such as local authority sites/local recycling centres; this will be free of any charges. **Do not return to Triton Showers.**



UK SERVICE POLICY

In the event of a product fault or complaint occurring, the following procedure should be followed:

1. Telephone Customer Service on **02476 378495** having available, your details including post code, the model number and power rating of the product, together with the date of purchase and, where applicable, details of the particular fault.
2. If required, the Customer Service Advisor will arrange for a qualified engineer to call.
3. All products attended to by a Triton service engineer must be installed in full accordance with the Triton installation guide applicable to the product. *(Every product pack contains an installation guide, however, they can also be bought via our Customer Service Spares Department).*
4. Our engineer will require local parking and if a permit is required this must be available to the engineer on arrival at the call.
5. It is essential that you or an appointed representative (*who must be over 18 years of age*) is present for the duration of the service engineer's visit. If the product is in guarantee you must produce proof of purchase.
6. Where a call under the terms of guarantee has been booked and the failure is not product related (*i.e. scaling and furring, incorrect water pressure, pressure relief device operation or electrical/plumbing installation fault*) a charge will be made. A charge will also be issued if nobody is at home when the service engineer calls or adequate parking/permit is not available.
7. If the product is no longer covered by the guarantee an up front fixed fee will be charged before the site visit.
8. Should proof of purchase not be available on an "in-guarantee" call, or should the service engineer find that the product is no longer under guarantee, the engineer will charge the same fixed price and the customer will be expected to pay the engineer before he leaves. If payment is not made on the day an administration charge will be added to the fixed charge.
9. If a debt is outstanding from a previous visit, or from any other Triton purchase, Triton reserves the right to withhold service until the debt has been settled.
10. Triton takes the health, safety and wellbeing of its employees very seriously and expects customers to treat all staff members with respect. Should any employee feel threatened or receive abuse, either verbally or physically, Triton reserves the right to withhold service and will support the employee with a legal prosecution.

Replacement Parts Policy

Availability: It is the policy of the manufacturer to maintain parts availability for the duration of production and a period of five years thereafter, in accordance with industry standards.

Spare parts are available via our website, www.tritonshowers.co.uk, or by telephoning Triton Customer Service Spares Department. Payment should be made by credit/debit card (excluding American Express or Diners Card). Payment can also be made by pre-payment of a pro forma invoice by cheque or money order.

Telephone orders are based on information given during of the call.

Before contacting Triton, please verify your requirements using the information contained in the supplied user guide. Triton cannot accept liability for incorrect part identification.

TRITON STANDARD GUARANTEE

With the exception of accessories, Triton guarantee the product against all manufacturing defects for a period of **1 year** (for domestic use only) from the date of purchase, provided that it has been installed by a competent person in full accordance with the fitting instructions.

All accessories such as shower heads, hoses and riser rails carry a **1 year** parts only guarantee against manufacturing defects.

Any part found to be defective during this guarantee period we undertake to repair or replace at our option without charge so long as it has been properly maintained and operated in accordance with the operating instructions, and has not been subject to misuse or damage. This product must not be taken apart, modified or repaired except by a person authorised by Triton. This guarantee applies only to products installed within the United Kingdom and does not apply to products used commercially. This guarantee does not affect your statutory rights.

What is not covered:

1. Breakdown due to: **a)** use other than domestic use by you or your resident family; **b)** wilful act or neglect; **c)** any malfunction resulting from the incorrect use or quality of electricity, gas or water or incorrect setting of controls; **d)** failure to install in accordance with this installation guide
2. Claims for missing parts once the product has been installed.
3. Repair costs for damage caused by foreign objects or substances.
4. Total loss of the product due to non-availability of parts.
5. Compensation for loss of use of the product or consequential loss of any kind.
6. Call out charges where no fault has been found with the appliance.
7. The cost of repair or replacement of pressure relief devices, showerheads, hoses, riser rails and/or wall brackets, isolating switches, electrical cable, fuses and/or circuit breakers or any other accessories installed at the same time.
8. The cost of routine maintenance, adjustments, overhaul modifications or loss or damage arising therefrom, including the cost of repairing damage, breakdown, malfunction caused by corrosion, furring,
9. Call out charges where the water supply cannot be isolated, this includes consequential losses arising from unserviceable supply valves.

For the latest Terms & Conditions, please see: www.tritonshowers.co.uk

Triton Showers
Triton Road
Nuneaton
Warwickshire CV11 4NR

Triton is a division of Norcross Group (Holdings) Limited

Customer Service: ☎ 02476 378495
Fax: 02476 324504

www.tritonshowers.co.uk

E-mail: serviceenquiries@tritonshowers.co.uk