

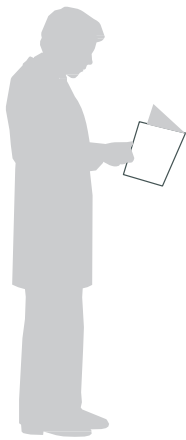

INSTRUCTION





MIXER PART:
≤ 5 bar
≤ 70°C

BOILING WATER PART:
≤ 3 bar
≤ 110°C

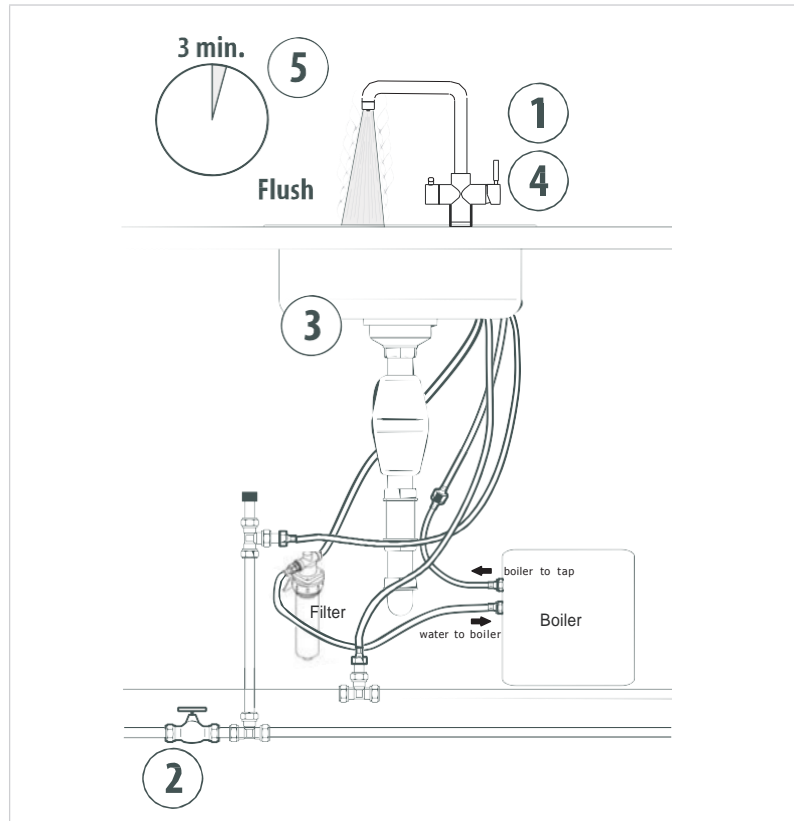
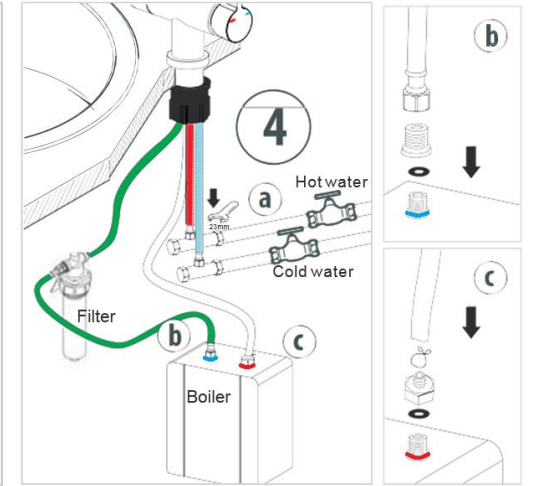
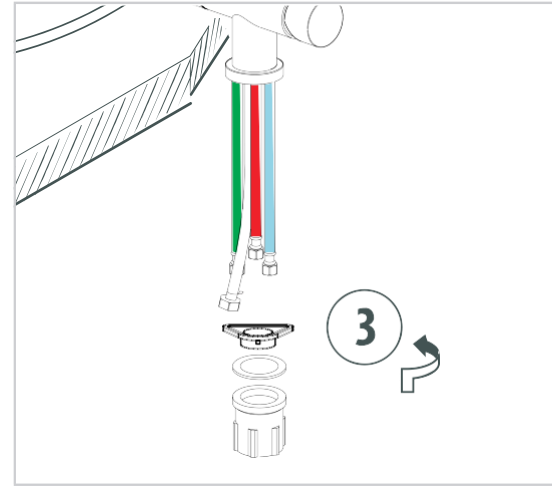
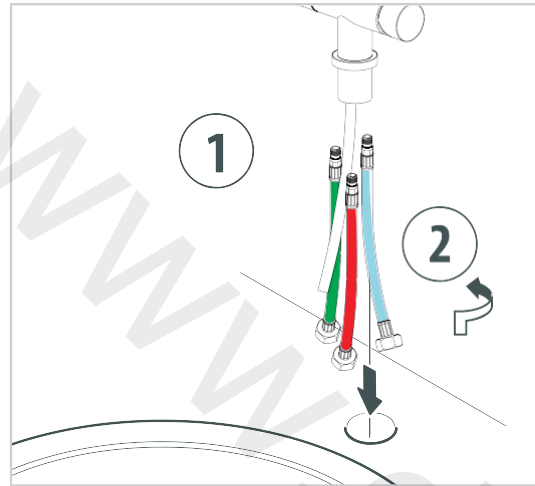

Installation Procedure:

1. Unscrew the fixing nut off the tap.
2. Install the hoses onto the tap.
3. Insert the hoses through the tap hole. Note: Insert hot/cold hose first, then the boiled in hose by inclining the nut. Insert the silicon tube lastly.
4. Slide the gasket and white retaining plate on the threaded tube. Tighten them firmly.
5. Connect the hoses as instructed (water to boiler connects to filter, silicon tube connects to C as shown above).

The picture illustrates these connections:

- a. cold water hose and hot water hose
- b. hose for cold water from tap to boiler
- c. hose for boiled water from boiler to tap

Option: If necessary, install a filter valve on either side of the water filter for easy access and maintenance.

Filling and venting the heating tank.

1. Close the boiling water tap.
2. Open the mains valve.
3. Open the cold tap side to purge water through the tap
4. Open the boiling water valve to fill in the tank until water flows out from the tap.
5. Let the water flow for 3 minutes until clear water flows from the tap. Check for leaks, rectify as necessary. Refer to boiler instructions for set up process

