

FORGE

stainless steel mini basin mixer

20004010565



INSTALLATION GUIDELINES

1. Installation should be carried out by a competent engineer, in accordance with water regulations.
2. If isolating valves aren't already fitted, fit them to the inlet feeds.
3. Before installation, ensure supply pipes are flushed clean. Debris or loose particles will affect the efficiency of the ceramic disc cartridge. Failure to flush through pipe work before installation of taps may cause serious damage to the ceramic disc cartridge and can cause the tap to drip for which bathstore will not be liable.
4. Hot & cold pressures should be equally balanced.
5. To prolong the life of the cartridge in hard water areas and reduce servicing periods we recommend that a suitable water softener is fitted.

Remember to turn off the mains water supply before connecting to any existing pipe work.

Screw the flexible pipes into the mixer body and fully hand tighten. Place the mixer in position to see if pipework needs altering. After making any necessary alternations to the pipework, pass the mixer base ring and washer over the flexible pipes and threaded stud to form a seal on the sink top. Pass the tails and fixing stud through the hole in the basin from above, and place the mixer in position on the basin. Slide the C-shaped black washer and then the metal retaining plate up the tails and secure screwing the fixing nut finger tight. Check that the mixer body is correctly positioned to the rear and tighten fixing but. The tap needs to be fixed firmly but do not over tighten as damage may be caused to the basin. Hot water should be connected to the left inlet when the tap is viewed from the front.

ATTENTION

Having first checked all new connections, turn on the mains water supply, close all taps except the new mixer and as the system starts to refill check for leaks.

Once you have satisfied yourself that there are no leaks, switch on the water heating.

DIMENSIONS:

Height of the body	158mm
Reach of the spout	89 mm

CARE AND MAINTENANCE:

To maintain the appearance of this product, ensure that it is regularly cleaned only using a clean, soft damp cloth. A solution of warm water and a mild detergent may be used where necessary, and then the fitting rinsed thoroughly and wiped dry. Any other cleaning action will invalidate your warranty.

If the mixer tap has a diffuser it should be unscrewed and cleaned periodically in warm water.

Abrasive cleaners, scouring cleaners and acidic cleaners must not be used under any circumstances. Avoid contact with all solvents (including chlorinated solvents, ketones or acetones as these may result in surface deterioration or etching). Read the instructions on any cleaning product before using it to ensure that it won't damage the surface.

Isolate the water to the tap before performing any form of internal maintenance.

CLEANING THE CARTRIDGE

The cartridge should give trouble free service, but in the event of any problems, servicing is straight forward.

Use an Allen key to loosen the screw on the handle but do not remove it. Pull off the handle and unscrew the cover. Using the correct size spanner unscrew and remove the retaining nut. Pull out the cartridge taking note of its orientation. Wash the cartridge with clean running water and make sure that any trapped debris has been removed. Dry and lightly grease the seal (only use silicone grease) and replace the cartridge followed by the nut, cover and handle.

DIMENSIONAL DRAWING

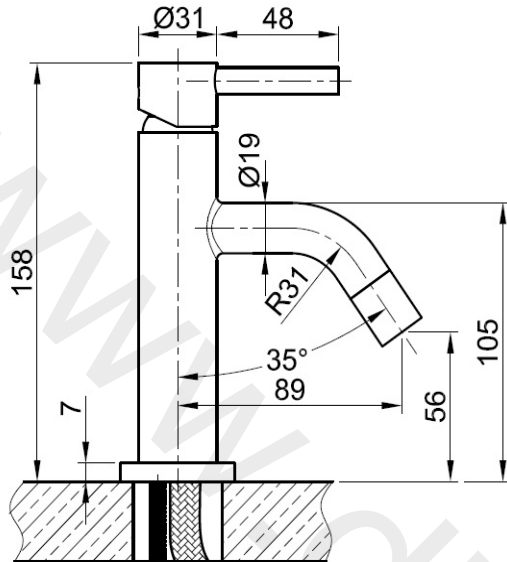

EXPLODED PARTS – DRAWING

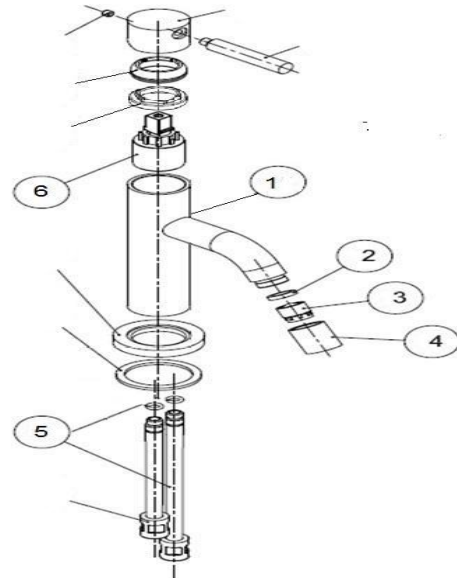

Please refer to part numbers when contacting Bathstore.

FLOW RATE & OPERATING CONDITIONS

Recommended water pressure 1 – 3 bar

Optimum water pressure 3 bar

0.5 bar	5.5 L/Min
1 bar	6.8 L/Min
2 bar	8.5 L/Min
3 bar	10.8 L/Min