

# 6

## PARTS - PILLAR TAPS AND S/L BATH FILLER

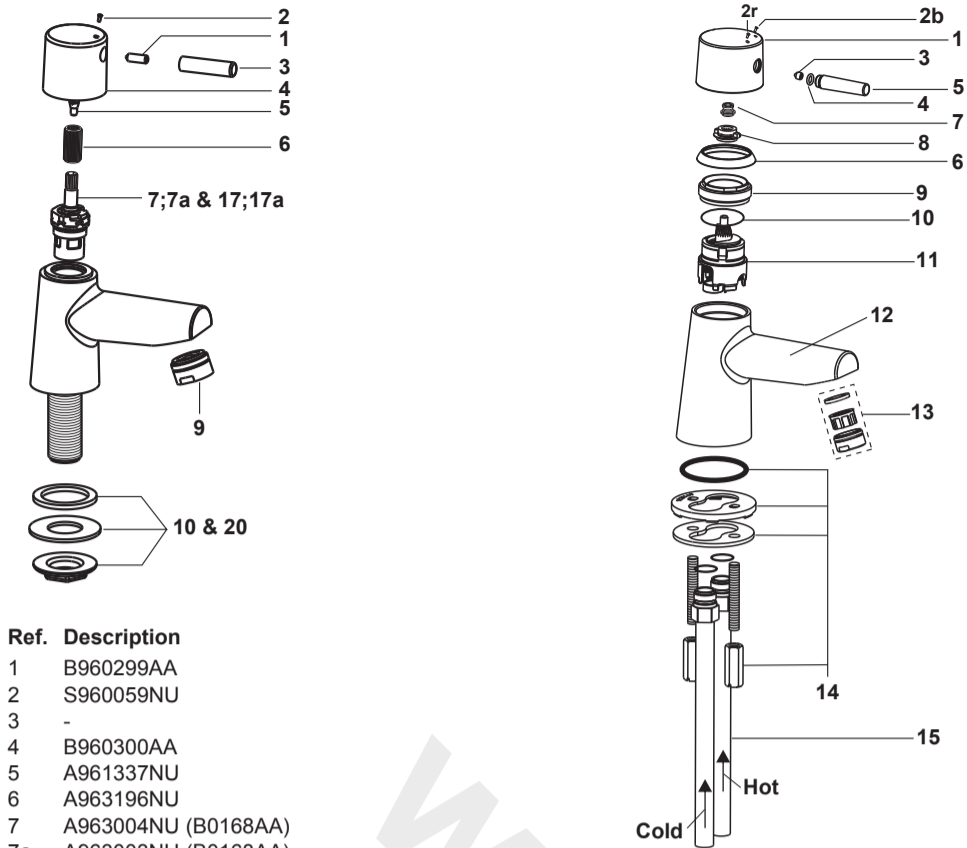

Ref.	Description
1	B960299AA
2	S960059NU
3	-
4	B960300AA
5	A961337NU
6	A963196NU
7	A963004NU (B0168AA)
7a	A963003NU (B0168AA)
8	-
9	A960932AA
10	B960480NU (B0168AA)
17	A961010NU (B0169AA)
17a	A960462NU (B0169AA)
20	B960471NU (B0169AA)

Figure 6 Pillar Taps - Basin B0168 & Bath B0169

# 7

## PARTS - S/L BASIN

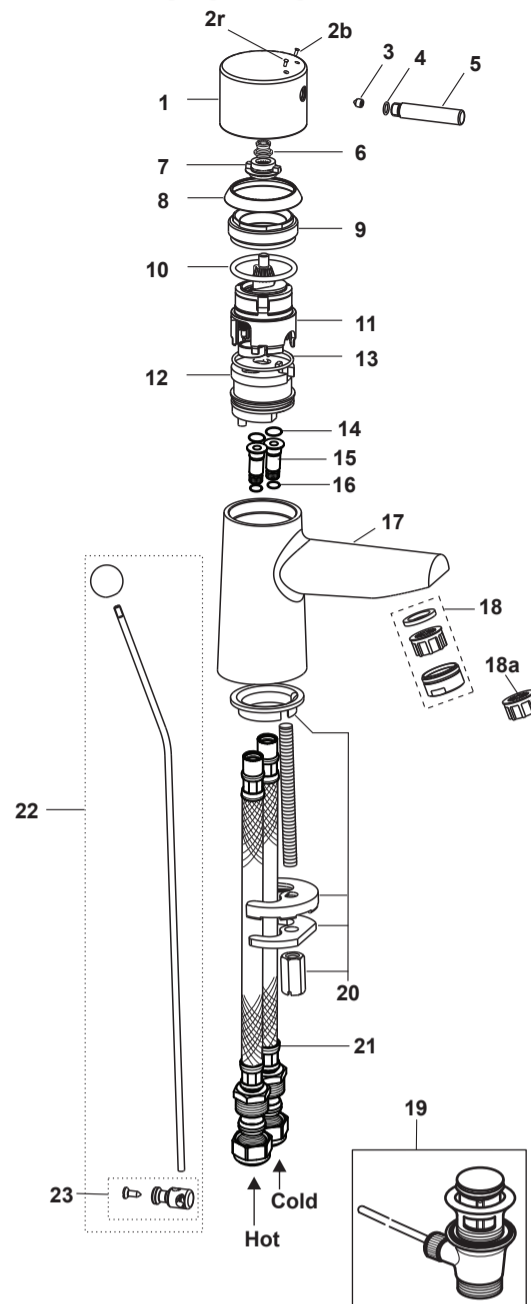

Ref.	Description
1	B960304AA
2	S960059NU
3	-
4	-
5	-
6	-
7	A960034NU
8	B960298AA
10	-
11	A962985NU
12	-
13	-
14	-
15	-
16	-
17	-
18	B960754AA
18a	A962713NU
19	S9636AA
20	B960608NU
21	A960485NU
22	B960839AA
23	-

Ref.	Description	Ref.	Description
1	B960304AA	12	-
2	S960059NU	13	A961625AA
3	-	14	B960492NU
4	-	15	A960133NU
5	-		
6	B960298AA		
7	-		
8	A960034NU		
9	-		
10	-		
11	A960145NU		

Figure 7 Single Lever Bath Filler B0171

Figure 8 Single Lever Basin B0170

# 8

## PARTS - BATH SHOWER MIXER & BATH FILLER

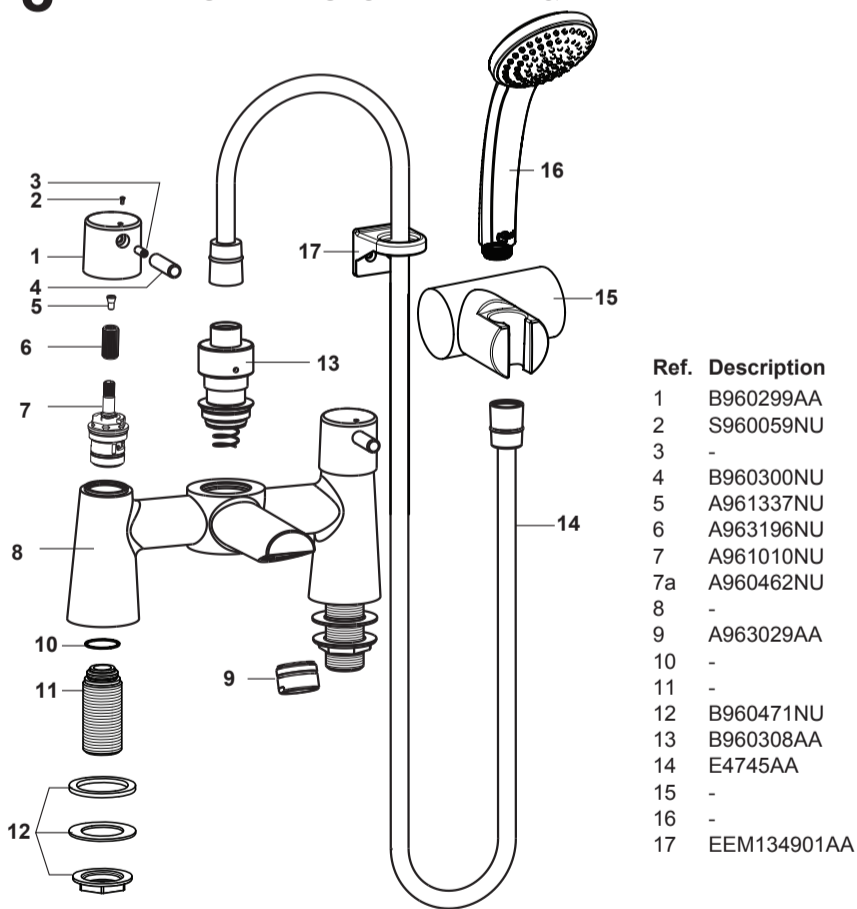

Ref.	Description
1	B960299AA
2	S960059NU
3	-
4	B960300NU
5	A961337NU
6	A963196NU
7	A961010NU
7a	A960462NU
8	-
9	A963029AA
10	-
11	-
12	B960471NU
13	B960308AA
14	E4745AA
15	-
16	-
17	EEM134901AA

Figure 9 Deck Mounted Bath Filler B0172 and Bath Shower Mixer B0173

## SENSES SPHERE

### SINGLE LEVER & DUAL CONTROL BATHROOM FITTINGS

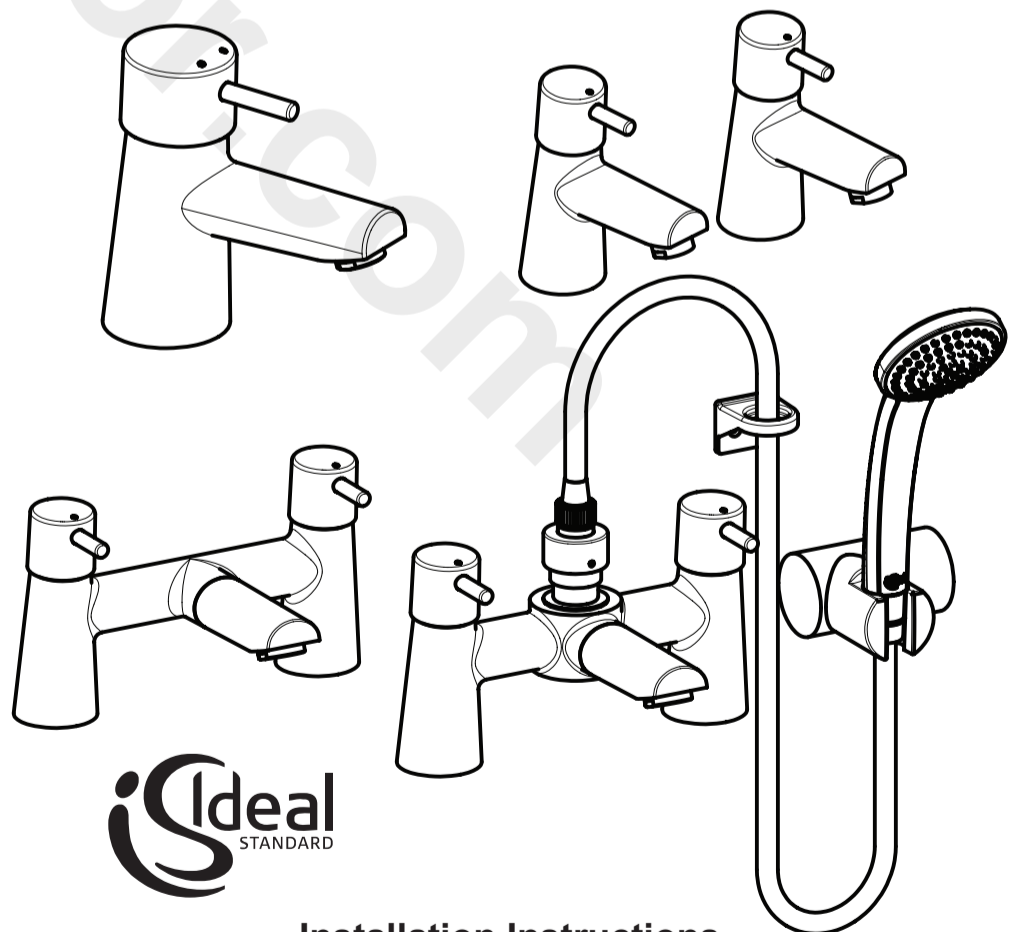

### Installation Instructions

- B0168** Senses Sphere Basin pillar taps
- B0169** Senses Sphere Bath pillar taps
- B0170** Senses Sphere S/L basin mixer with pop-up waste
- B0171** Senses Sphere S/L bath filler
- B0172** Senses Sphere 2 Hole bath filler
- B0173** Senses Sphere 2 Hole bath shower mixer with shower set

**INSTALLER:** After installation please pass this instruction booklet to user

### CUSTOMER CARE HELPLINE

**0870 125 8905**

Ideal Standard pursues a policy of continuing improvement in design and performance of its products. The right is therefore reserved to vary specification without notice. Ideal Standard is a division of Ideal Standard (UK) Ltd

Ideal Standard  
The Bathroom Works, National Avenue  
Kingston-upon-Hull, HU5 4HS England

### E-MAIL

**ukcustcare@idealstandard.com**

Ideal Standard International BVBA  
Corporate Village - Gent Building  
Da Vincilaan 2  
1935 Zaventem  
Belgium

The fittings covered by this installation and maintenance instruction should be installed in accordance with the water regulations published in 1999\*, therefore Ideal Standard would strongly recommend that these fittings are installed by a professional installer

\*A guide to the Water Supply (Water fittings) Regulations 1999 and the Water Byelaws 2000, Scotland is published by WRAS (Water Regulations Advisory Scheme) Fern Close, Pen-y-Fan Industrial Estate, Oakdale, Newport, NP11 3EH. ISBN 0-9539708-0-9

### Connections

Basin pillar taps	G ½
Bath pillar taps & two hole fittings	G ¾
SL Basin mixer	Flexible tails with 15mm compression connections
SL Bath filler	15mm copper tails

### IMPORTANT NOTE

All fittings except the Single Lever Bath Filler follow the convention of having the hot water connection on the left. The S/L Bath Filler (B0171) however, has the hot connection on the right.

### Water Supplies

All fittings are designed for installation on normal UK low pressure storage tank fed systems or unvented high pressure systems. With mixers, it is a requirement that hot and cold supplies be at reasonably balanced pressures and from a common source, i.e. both from a low pressure gravity fed system, or both from a high pressure unvented system.

B0168AA, B0170AA, B0171AA, B0172AA and B0173AA are designed to operate in the pressure range 0.1 bar to 5.0 bar. B0168AA are designed to operate in the pressure range 0.2 bar to 5.0 bar.

All mixer fittings are supplied with a flow straightener in the spout except the basin mixers B0170AA.

The basin mixers B0170AA have a 5 litre/min regulated aerator (B960754AA) and a flow straightener insert (A962713NU) When fitting on pressures below 1.0 bar it is recommended that the aerator insert (fitted) should be substituted with a flow straightener insert.

### Safety

To ensure safety with bath mixers installed on low pressure tank fed systems, it is strongly recommended that the cold water feed from the storage tank is connected below the feed to the hot water storage cylinder.

### Backflow Protection

The water regulations published in 1999\* take a new approach to backflow in that they look at different categories of risk.

The installer must assess the risk from the various categories of fluid in adjacent appliances before determining the level of backflow protection required for a particular installation.

A separate leaflet entitled

**Supplementary guidance on back flow prevention when installing bath shower mixers E965049**

which is packed with every bath shower mixer, gives full details of this requirement.

### Installation

Flush water through the pipework before connecting the fittings.

Insert the fitting through the tap hole ensuring the o-ring seal or gasket is positioned above the tap platform and is seated evenly on its top surface.

Tighten the backnuts or clamping nuts.

(Figure 2)

### IMPORTANT NOTE

The one hole bath filler is designed for a corner installation (see Fig 1) or a position along the front side rim of the bath. Do not fit in line with the overflow assembly.

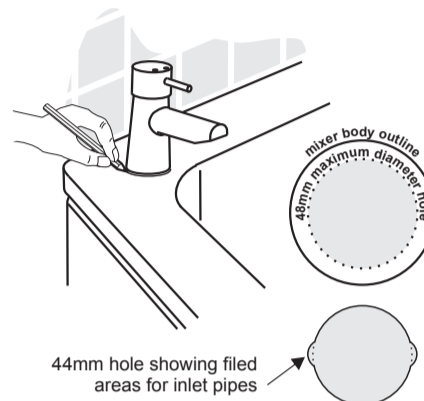

Figure 1 Tap hole details for S/L bath filler B0171

The Sphere monoblock bath fitting requires a bath supplied without tap holes. The installer will have to drill a 48mm diameter hole in the rim. Before this is done the following will have to be considered.

If located directly in line with the overflow the pop-up waste may foul the under-parts of the fitting.

If a shower screen is to be fitted it could foul the fitting.

### NOTE

Although 48mm cutters are available from most manufacturers, they are not yet as commonly available at trade counters as other sizes. It is important if making-do with a wrong size cutter to ensure that it is not greater than 48mm

e.g. A 1 1/4" (44mm) cutter can be used and the hole filed out locally to accommodate the inlet pipes. (Figure 1)

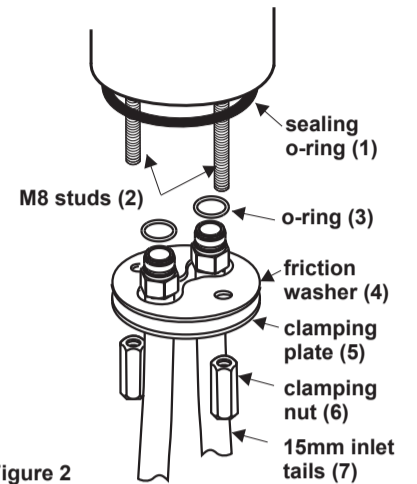

Figure 2

Before fitting the tails, offer up the bath S/L in the intended location and check for free movement of the lever. Draw a pencil line around the base (Figure 1)

In the center of the of the outline, drill the 48mm hole. (Figure 1)

Fit the supply tails (7) ensuring the O-rings (3) are correctly located in the groove below the M18 threads. Place the sealing o-ring (1) in the groove on the underside of the fitting base.

Place the fitting concentrically in the new tap hole and ensure the sealing o-ring (1) is seated correctly on top of the bath. The plate and washer (4 & 5) must be placed against the underneath surface of the bath tap deck. Tighten the clamping fixation nuts until the fitting is secure. (Figure 2)

Always turn off water supplies before replacing a cartridge

### Quarter turn cartridge

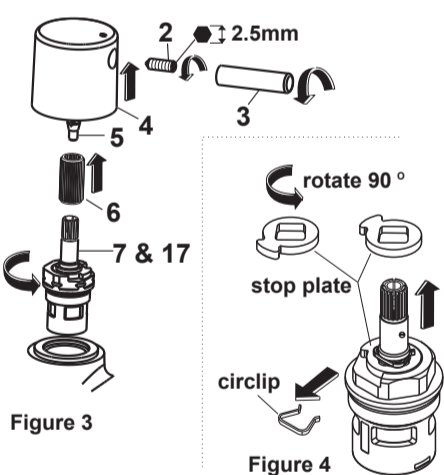

Figure 3

Figure 4

The pillar taps and 2 hole bath fittings employ SE quarter turn cartridges. These are replaced as follows (refer to Figure 3):

Remove handle by first unscrewing handle pin (3) - use several layers of masking tape if pliers have to be used - then unscrew grub screw (2). Lift off the handle (4).

Unscrew cartridge screw (5) and lift off drive insert (6). Cartridge (7 or 17) can then be unscrewed (counter clockwise). (Figure 3)

The direction of normal spindle rotation of the cartridge can be reversed by rotating the stop plate by 90° (refer to Figure 4).

Prise off circlip and lift off stop plate. Replace stop plate rotated by 90° and refit circlip. (Figure 4)

### Single lever cartridge

Refer to Figure 5. Unscrew handle pin (7) Wrap several layers of masking tape around it if pliers need to be used.

Unscrew grub screw (3) and lift off handle body (1). Unscrew retaining nut (4) and lift off drive insert (5). Lift off shroud (8) and retain to use on the replacement cartridge.

Unscrew cartridge retaining nut (9) and lift out the cartridge (11)

Replace in reverse order.

When fitting the new cartridge, care must be exercised to ensure the plastic location pin on the cartridge base engages in the location hole inside the fitting body and not into one of the water inlet ports.

When tightening the retaining nut which both locates and seals the cartridge, care must be taken not to over-tighten.

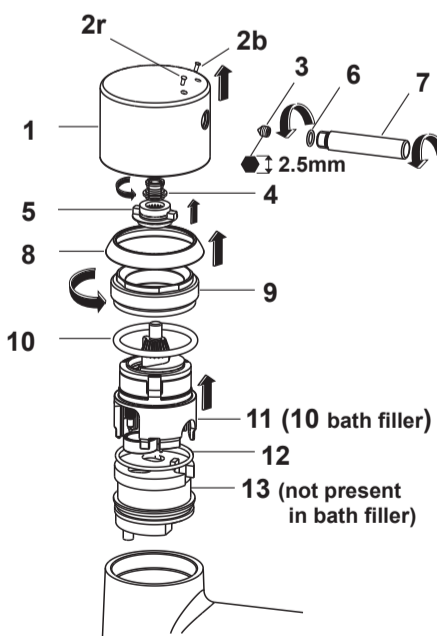

Figure 5 Single lever cartridge assembly (drawing shows basin monoblock)

The ideal torque is 4 Nm. This is only a little more than hand tight - indeed it is possible to tighten the nut sufficiently wearing stout gloves. If over-tightened the cartridge will be stiff to operate and will have a reduced life.

**Note: The bath cartridges, although they look similar to the basin cartridges, are constructed to give a higher flow rate and are therefore different.**

The single lever fittings employ multiport cartridges which have a blend control mechanism. This is a simple mechanical limit stop located under the single lever handle which restricts the angle to which the handle can be rotated towards the full hot position.

To set it, the hot water system should be on and the hot water up to normal working temperature. A thermometer will be required to measure the maximum blend temperature.

Remove the handle as previously described and pull off shroud. (Figure 5)

The blend control stop (white crescent shaped plastic moulding - shown shaded) can then be removed.

In its factory set position "0" - shown dotted in Figure 10 - it does not limit the lever handle movement therefore the water temperature will be at its highest.

Insert the limit stop in position 4 - shown shaded in Figure 10.

Operate the fitting and measure the mixed

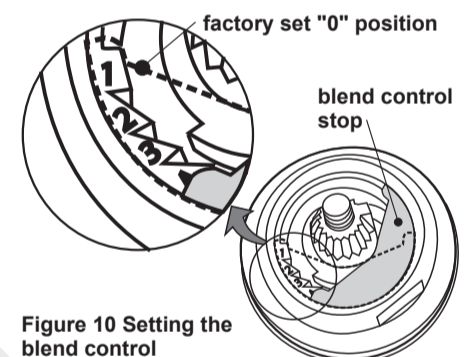

Figure 10 Setting the blend control

water temperature at the maximum setting.

If not high enough, reposition the stop in position 3 and check the temperature again.

Repeat the process until the temperature at the maximum temperature position is satisfactory. Refit the shield and handle and check that the maximum blend temperature remains unchanged.

### SAFETY FOR THE USER

The fittings are not thermostatically controlled and outlet temperatures depend on the position of the control handle, the hot and cold temperatures and pressures. If cold water supply fails for any reason, only hot water at its maximum temperature will be delivered.

Before using the handspray check that the temperature of the mixed water is satisfactory. Young children, the elderly and infirm should be supervised when using the bath or handspray.

### CLEANING

When cleaning the fittings always use soap based cleaners.

Never use abrasive or scouring powders and never use cleaners containing alcohol, ammonia, nitric acid, phosphoric acid or disinfectants.