

nabis
fits perfectly

Mono Kitchen Mixer

Instruction & Warranty Leaflet

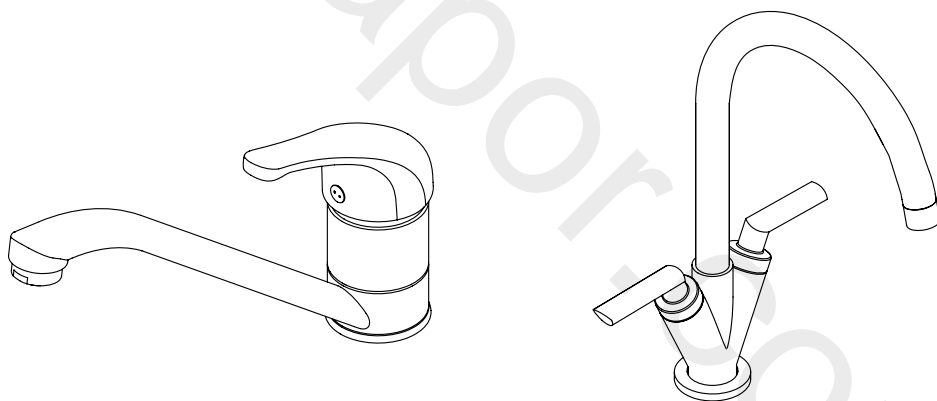

Product code:

B08911 B08912 B08913 B08914 B08915 B08917 B08921 B08923 B08925 B08926 B08927

Tap head shown is for illustration purposes only.

Please keep this instructions for future reference and request of replacement parts.

Water Regulations Requirements

It is important to ensure that the water supplies to your taps and mixers are connected in accordance with the water regulations (WRAS) requirements and good plumbing practice.

It is Wolseley's recommendation and good plumbing practice that the supplies of hot and cold water to the products should be equal (balanced) pressures in order to provide a consistent flow. Supplies should be from a common source. Either mains or tank fed. If supplies are not equal pressures then non return valves should be fitted (not supplied).

These products have been designed to function on all types of water of water systems.

Please note: if a pump is to be installed to boost gravity supplies please refer to the pump manufactures instructions.

The hot and cold inlets for any of the products are hot on the left and cold on the right when viewed from the front of the fitting. It is our recommendation and good plumbing practice that a service valve also should be installed up stream in the inlet supply lines.

Pipe Connections

IMPORTANT. Before making any inlet pipe connections all supplies MUST be thoroughly flushed to remove any debris.

Failure to do so could result in damage or low flow from the fitting.

It is a requirement of Byelaw 55 of the Water Fittings Byelaw Scheme that this function is undertaken before making any pipe connections to supplies.

General Installation Notes

- Care must be taken during installation to prevent any risk of damage to the product or injury to installer.
- Installation must be carried out by a qualified and competent person and in accordance with the instructions supplied.
- Installations must comply with all Local and National Water Authority Regulations and Building/Plumbing Regulations.
- Ensure that you have read and understood all sections of this manual before installation.

Water Supply Pressures

All fittings have been designed to function under the following conditions:

- Minimum supply pressure: 0.2 bar
- Maximum supply pressure: 5.0 bar

Generous flow rates are achieved at pressures as low as 0.2bar. At high pressures it maybe necessary to reduce excessive flow rates by fitting stop or servicing valves in the supply line before the mixer or tap. These stop valves facilitate ease of maintenance should it be necessary.

Installation Requirements

Flexible Pipes Connection

Please ensure flexible pipes are connected to the household pipework with extra care to avoid the flexi pipes are not kinked, twist or bent sharply.

Below are recommended ways to fit the flexible pipes during tap installation. Failure to follow the below recommended guidelines may damage the flexible pipes or poor taps performance.

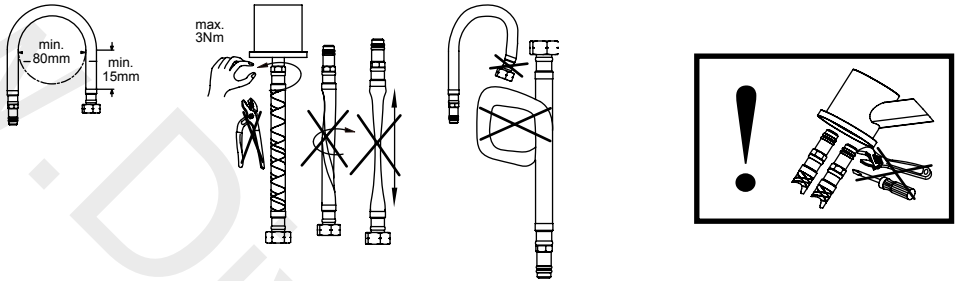

Mono kitchen mixer

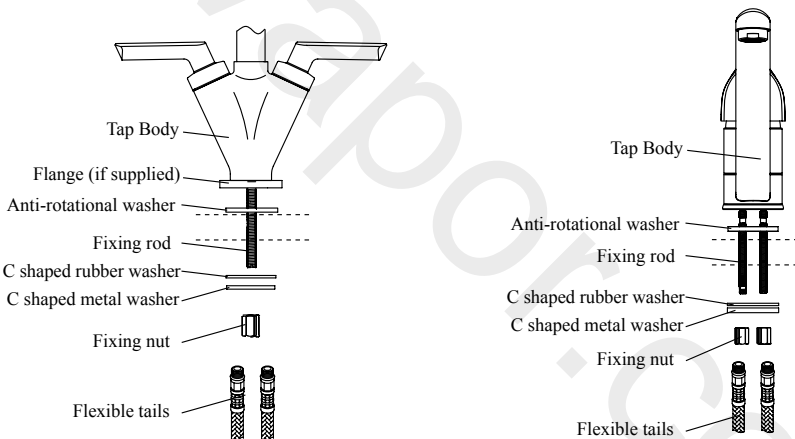

1. Identify all components and check for completeness, particularly before commencing installation.
2. Screw fixing rod to tap body and tighten it.
3. Fit flange to tap body, ensuring that the anti-rotational washer is fitted between the flange and the sink. if the flange is not supplied, fit anti-rotational washer directly to the tap body.
4. Screw 2x flexible tails into tap body, do not over tighten.
5. Locate the tap assembly down through the tap hole in sink.
6. Slide the C shaped rubber washer and the C shaped metal washer onto the fixing rod up to the underside of the sink. To secure the mixer in place tighten the fixing nut onto the fixing rods until they fully tightened against the C shaped metal washer.
A suitable spanner may be required to fully tighten the fixing nuts.
7. Connect the flexible tails to the hot and cold water supplies.
8. Turn on the mains water supply letting the water flow for a few minutes to flush through the system.
9. Check all joints and connections for any leaks.

Component Diagram

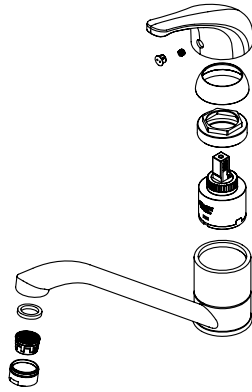
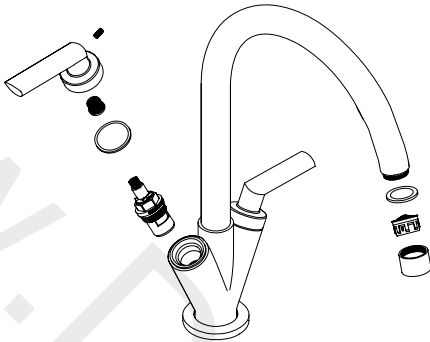

Care & Maintenance

To maintain the surface finishes, simply wipe occasionally with a mild detergent on a soft damp cloth. Dry using a soft cloth, never use abrasive cleaners or chemical household cleaners, and avoid contact with concentrated bleach.

Nabis products are manufactured to the highest of standards and should require little or no maintenance. In the unlikely event of any spare part requirements, please contact our free phone helpline number.

Free Phone Helpline

Should you require any technical help in association with your Nabis products please call 0344 292 7062 with your query.

Warranty: 5 Years

For detail warranty information, please visit our website: plumbcenter.co.uk

Address:

Plumb & Parts
Wolseley Center
Harrison Way
Leamington Spa
CV313HH

Website:
Plumbcenter.co.uk

