

INSTALLATION AND MAINTENANCE GUIDE

BC633F

ELECTRONIC FOAM SOAP DISPENSER

Saving soap, saving power, promoting hygiene



Important:

Read carefully before installing product



INDEX

- 3 Technical Data
- 4 Pre-Installation Info
- 6 Pack Contents
- 7-9 Installation
- 10 Filling The Soap Tank
- 11 Settings Adjustment
- 12 Spare Parts List
- 13 Maintenance
- 14 Warranty
- 15-17 Troubleshooting

TECHNICAL DATA

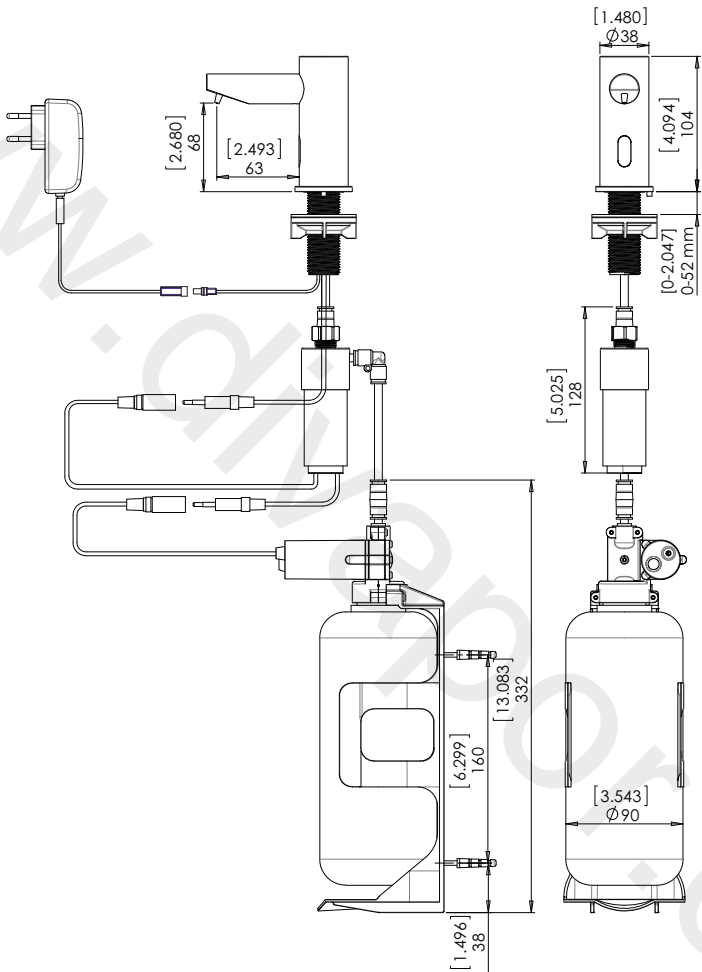

Capacity Litre	33.8 oz.
Power Supply	12V transformer
Soap viscosity	1-4cPs
Standard discharge	Varies according to viscosity and soap consistency
Sensor range	30-100 mm ± 10 mm / 1.18-3.94" (customisable by optional remote control)

PRE INSTALLATION INFORMATION

Check contents

Separate all parts from the packaging and check each part with the "Pack contents" section.

Make sure all parts are accounted for before discarding any packaging material.

If any parts are missing, do not attempt to install your touch free soap dispenser until you obtain the missing parts.

Warnings

Do not install your electronic soap dispenser facing a mirror or any electronic system operated by an infrared sensor.

To prevent reflection problems, it is recommended to keep a minimum distance of 5' (1.5m) between the soap dispenser sensor and any other directly facing objects and a minimum of 6" (150 mm) between the soap dispenser and the adjacent tap.

IMPORTANT: Keep in mind that when using the tap installed next to the soap dispenser, the user hands should not interfere with the soap dispenser sensor detection area.

Correct Installation

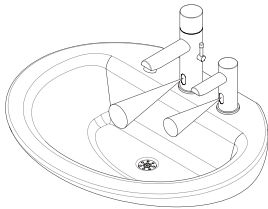

Incorrect installation

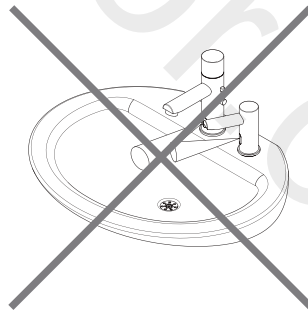

**DO NOT AIM SOAP SENSOR
AT WATER STREAM**

PRE INSTALLATION INFORMATION

Dolphin foam soap dispensers, with proper care, will provide long term trouble free service. Quality foam soap of recommended viscosity and pH levels are the main factors for smooth operation of your dispenser. If needed, use a viscometer to verify the viscosity of your soap to ensure maximum benefit. The recommended range for foam soap viscosity is 1-4cPs. Thicker foam soap flows slower and inhibits the pump valve, causing strain and damage.

Dolphin foam soap dispensers are suitable for use with any generic foam soap of the correct viscosity and pH. The pH level of all soap used in Dolphin foam soap dispensers should be between 6.5 to 8.5. Lower levels will cause corrosion to the metal dispenser and even the rubber and plastic components. Higher pH levels will cause swelling to rubber parts and degradation of plastic components over time.

PACK CONTENTS

Familiarise yourself with the part names and confirm that the parts are included.

1 x foam
dispenser body

1 x foam
compressor
with pipe

12v transformer

1 x pump
assembly with
bottle support
and soap tank

2 x screws and
2 x anchors

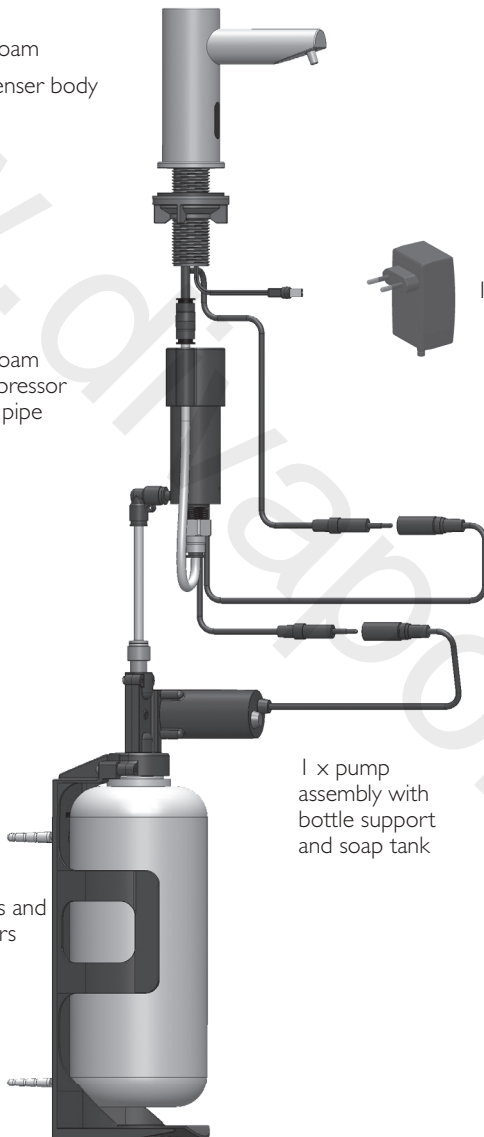

INSTALLATION

Step 1 – remove all mounting hardware

Drill a hole (25-29mm) in the deck or lavatory for the soap dispenser body and a small hole (4) for the anti rotation pin.

Disassemble the nut, disk and gasket from the base of the soap dispenser body.

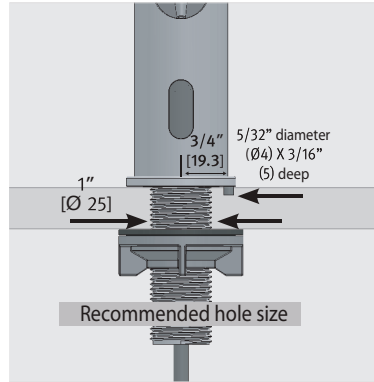

Step 2 – installing the soap dispenser

- 1 Insert the soap dispenser body and the anti rotation pin along with the rosette into the holes drilled.
- 2 Under the deck, secure the gasket, disk and nut over the soap dispenser body nipple.

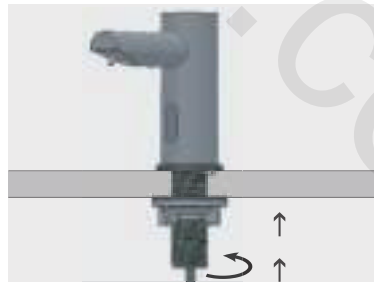

INSTALLATION

- 3 Fix the bottle support to the desired location. The pump MUST be within reach range of the Com cable and black supply tube.



- 4 Connect the quick connection fitting to the soap dispenser pump. Make sure it is firmly plugged in.

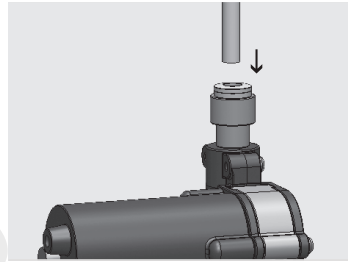

5. Connect the second soap tube provided in the packaging from the compressor to the quick connection fitting at the top of the soap dispenser pump assembly by snapping it in.



IMPORTANT: Make sure to cut the soap tube to the minimum required length

INSTALLATION

Step 3 – Connecting the power source

- 1 Remove the protective sticker covering the sensor.



- 2 Connect the soap dispenser pump connector to its matching connector on the electronic unit. Please note that since the connector is waterproof, some pressure must be applied for a perfect seal.



O-RING VISIBLE –
NOT CONNECTED PROPERLY

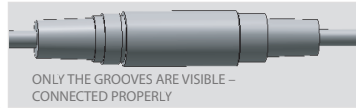

ONLY THE GROOVES ARE VISIBLE –
CONNECTED PROPERLY

IMPORTANT: the 4 contacts connector should be connected properly so that the white o-ring is not visible and a clicking sound is heard.

PAY ATTENTION : If the 4 contacts connectors are not connected properly, the soap dispenser pump will not operate properly.

3. Plug the transformer into the electricity socket and connect the transformer connector



4. Wait about 10 seconds before placing your hands in the sensor range to avoid adjustment mode.



FILLING THE SOAP TANK

- 1 Unscrew the soap tank from the pump assembly and pull it out of the bottle support.



- 2 Fill the bottle with foam soap to the top line. Make sure the bottle is clean before filling it with soap.



- 3 Insert the bottle inside the bottle support.



- 4 Screw the soap tank back into the pump assembly. Make sure the tank is firmly secured into place.



- 5 Press and hold the refill button located at the back of the pump assembly until soap is dispensed from the soap dispenser spout. Release the button once soap begins dispensing from the spout. Alternately, use the FILL function on the remote control (if available). see page 11.



Note :When the soap in the soap tank reaches the bottom line, the tank needs to be refilled.To refill the soap tank please refer to steps 1-5.



CARTRIDGE REFILLING INSTRUCTIONS

01

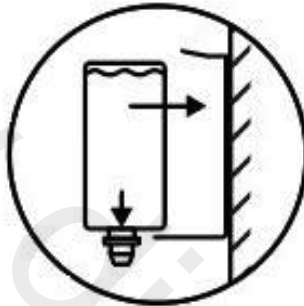

PULL OUT SPOUT
REMOVE FOIL SEAL
SLIDE INTO BRACKET

02



PUSH CONNECTOR
FIRMLY ONTO
REFILL SPOUT

03



CLICK INDICATES
SUCCESSFUL
CONNECTION

SETTINGS ADJUSTMENT WITH A REMOTE CONTROL

If available, the foam dispenser remote control can adjust the dispenser's settings. To use the remote control hold it in front of the sensor at a distance of 10-15cm (4-6"). **Attention:** The remote control will not operate out of the recommended range (too close or too far).

The remote control can be used to adjust the following functions:

1-SOAP QUANTITY

Press the + sign on the SOAP button to increase the soap quantity by increasing the dispensing time. Press the - button to decrease it. Indication: continuous blinking blue light in the sensor eye.

2-AIR QUANTITY

To improve soap consistency ("foamability") change the amount air to be mixed. Press the + sign on the AIR button to increase the air quantity and the - to decrease it. Indication: 2 blinks of the blue light in the sensor eye.

3-RES

This function resets the sensor back to its factory settings.

4-TEMPORARY OFF FUNCTION

This function temporary disables the dispenser. Use this function to preform maintenance in front of the sensor without activating the system (for example: cleaning). The soap dispenser will shut off for one minute after this button is pressed once. To return to normal operation before the minute is over, press the On/Off button again.

5-FILL THE SOAP TANK

Once the soap tank has been filled \refilled, press the FILL button. The pump will run for one minute, priming the piping with soap. Once soap begins dispensing from the spout, priming is complete. press the FILL button again to stop the priming before the minute is over. Indication: continuous solid blue light in the sensor eye.

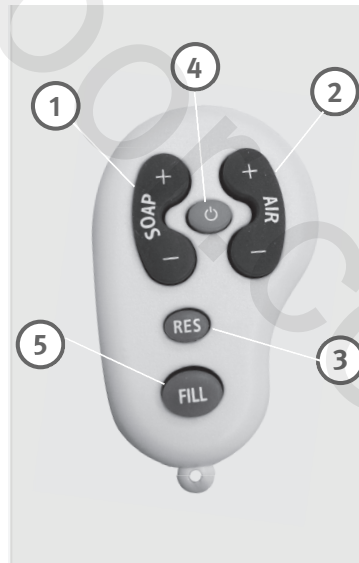

SPARE PARTS LIST

Seals & Screws Kit Elite/Trendy Foam	BC07210162
Seals & Screws Kit Green 28 Foam	BC07210164
10-Pack Sensor Kit Elite/Trendy Foam	BC07220331
10-Pack Sensor Kit Green 28 Foam	BC07220332
Soap Dispenser Pump	BC07222028
Pump+Compressor Kit	BC07222037
6-pack Soap Bottle 1L	BC07100035
6-pack 1L Bottle Support Klt	BC07100037
12V Transformer (EU)	BC06522081
12V Transformer (UK)	BC06522086
12V Transformer (US)	BC06522080
12V Transformer (AU)	BC06522085
Remote Control for Foam Dispenser (Optional)	BC07100009
Soap & Water Remote Control (Optional)	BC01700014

MAINTENANCE

Care and cleaning of chrome and special finishes

DO NOT use steel wool or cleansing agents containing alcohol, acid, abrasives, or their like. Use of any prohibited cleaning or maintenance products or substances could damage the surface of the soap dispenser. For surface cleaning use ONLY soap and water; then wipe dry with a clean cloth or towel. When cleaning bathroom tiles, the soap dispenser should be protected from any splattering of harsh cleansers.

Disassemble of the soap pipe from the pump

The soap pipe can be disconnected from the soap pump by a simple slide & pull action. The sliding ring of the quick connection fixation nipple on the pump should be pulled down. It releases the open end of the soap pipe which can then be easily pulled out.

Filter cleaning instructions (foam dispenser only)

This soap dispenser is provided with a foam filter. It is recommended to clean the filter every six (6) months. If the soap supply has decreased, this may be caused by the clogged filter. The filter can be cleaned as follows:

1. Use a wrench to unscrew the quick connection fitting from the foam compressor and pull out the filter housing.
2. Remove the filter from the housing.
3. Replace the filter (recommended) or wash it under running water for a temporary fix.
4. Reassemble the parts.

Clean the soap tank

Clean out the tank prior to refill by flushing warm water through the hoses and pump until clean water is released from the spout. TIP: Keeping a spare tank will enable this process to be completed in a speedy and hygienic manner with minimal downtime.

LIMITED WARRANTY

Dolphin Solutions Ltd. warrants that its electronic products will be free of defects in material and workmanship during normal use for two years from the date the product is purchased.

If a defect is found in normal use, Dolphin Solutions Ltd. will, at its discretion, repair, provide a replacement part or product, or make appropriate adjustments. Damage caused by accident, misuse, or abuse is not covered by this warranty. Improper care and cleaning will void the warranty. Proof of purchase (original sales receipt) must be provided to Dolphin Solutions Ltd. with all warranty claims.

Dolphin Solutions Ltd. is not responsible for labor charges, installation, or other incidental or consequential costs other than those noted above. In no event shall the liability of Dolphin Solutions Ltd. exceed the purchase price of the product.

If you believe that you have a warranty claim, contact your Dolphin Distributor, Dealer or Plumbing Contractor. Please be sure to provide all pertinent information regarding your claim, including a complete description of the problem, the product, model number, the date the product was purchased, from whom the product was purchased and the installation date. Also include your original invoice.

DOLPHIN SOLUTIONS LTD. AND/OR SELLER DISCLAIM ANY LIABILITY FOR SPECIAL, INCIDENTAL









OR CONSEQUENTIAL DAMAGES. This warranty excludes product damage due to installation error, incorrect maintenance, wear and tear, battery, product abuse, or product misuse, whether performed by a contractor, service company, or the consumer. This warranty does not cover product damage caused by the following:

- Incorrect installation.
- Inversions of supply pipes.
- Pressures or temperatures exceeding recommended limits.
- Improper manipulation, tampering, bad or lapsed maintenance.
- Foreign bodies, dirt or scale introduced by the water supply or soap tank.
- Use of the soap outside of viscosity specifications.
- Alteration of the original soap/foam dispenser components (including pipes).



TROUBLESHOOTING

Indication	Investigation	Cause	Solution	Illustration
False activation: Foam dispensing	Continuous discharge from the nozzle	AUX connector not fully inserted	The connector should be inserted fully until white o-ring is not visible. Remove the o-ring if necessary	
	Random discharge from the nozzle	Reflection issue from other object	Eliminate any cause of reflection and if necessary use appropriate remote control to shorten detection range.	
		Soap discharging from pump housing.	Replace the Pump. Rinse warm water through the pipe and the body of the soap dispenser all the way to the nozzle.	
Foam not dispensing	Pump and compressor are making a sound when sensor is activated	Soap tank is empty.	Fill with soap with correct viscosity (up to 1-4 Cps) and prime pipes using the fill button on remote control.	
		Soap dispenser has not been primed	Prime the soap dispenser by pressing the fill button on the remote or by pressing the refill button located at the bottom of the pump, until foam exits the nozzle.	
		Damaged pump (discharge from housing)	Replace the pump.	
		Debris or dried soap in the pipe or tank	Run warm water through pipe, pump, and body all the way to the nozzle. Replace with soap of correct viscosity. NOTE: Using the soap dispenser with high viscosity soap may cause permanent damage to the pump and shorten the lifecycle.	
		High viscosity soap (1-4 Cps)		
		Bent pipes	Unbend or straighten pipes.	

TROUBLESHOOTING

Indication	Investigation	Cause	Solution	Illustration	
Foam not dispensing	Pump is making a sound when sensor is activated, but the compressor is not.	Damaged pump	Replace the pump.		
	Compressor is making a sound when sensor is activated, but the pump is not.	AUX connector not fully inserted	Insert fully, remove the O ring if necessary	 	
Damaged Pump		Replace the pump.			
Foam not dispensing	Pump is not making sound when the sensor is activated	Sensor is blinking when hand is placed in front	AUX connector not fully inserted	The connector should be inserted fully until the white o-ring is not visible. Remove the o-ring if necessary	 
		Refill button on pump does not activate the pump.	Replace the Pump. Rinse warm water through the pipe and the body of the soap dispenser all the way to the nozzle.		
		Damaged pump (discharge from housing).			
		Debris or dried soap in the tank or tubing	Run warm water through pipe, pump, and body all the way to the nozzle. Replace with soap of correct viscosity. NOTE: Using the soap dispenser with high viscosity soap may cause permanent damage to the pump and shorten the lifecycle.		

TROUBLESHOOTING

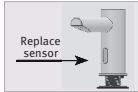
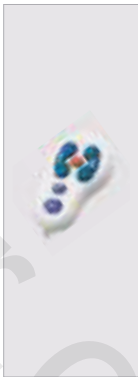
Indication	Investigation		Cause	Solution	Illustration
Foam not dispensing	Pump is not making sound when the sensor is activated	Sensor is not blinking when hand is placed in front	Refill button on pump does not activate the pump.	Transformer: Check operation with functioning transformer. Where necessary replace with appropriate transformer. For part numbers see spare parts list.	
			Reflection issue from other object	Eliminate any cause of reflection and use appropriate remote control to shorten detection range.	
			Damaged sensor	If the above two solutions have not resolved this issue replace with appropriate sensor. For part numbers see spare parts list.	
Foam not dispensing			Liquid rather than foam is being dispensed out of the nozzle	<ol style="list-style-type: none"> 1. Increase the air to soap ratio. 2. Verify that the filter is clean. 3. Replace compressor (supplied with pump). For part numbers see spare parts list. 	
Foam is dispensing		Foam dosage is too large	Use remote to decrease soap volume by pressing the "- Soap" key.		
		Foam dosage is too small	Use remote to increase soap volume by pressing the "+ Soap" key.		
		Foam is too dense	Use remote to decrease the amount of air in the foam by pressing the "- Air" Key.		
		Foam is too liquefied	Use remote to increase the amount of air in the foam by pressing the "+ Air" key.		

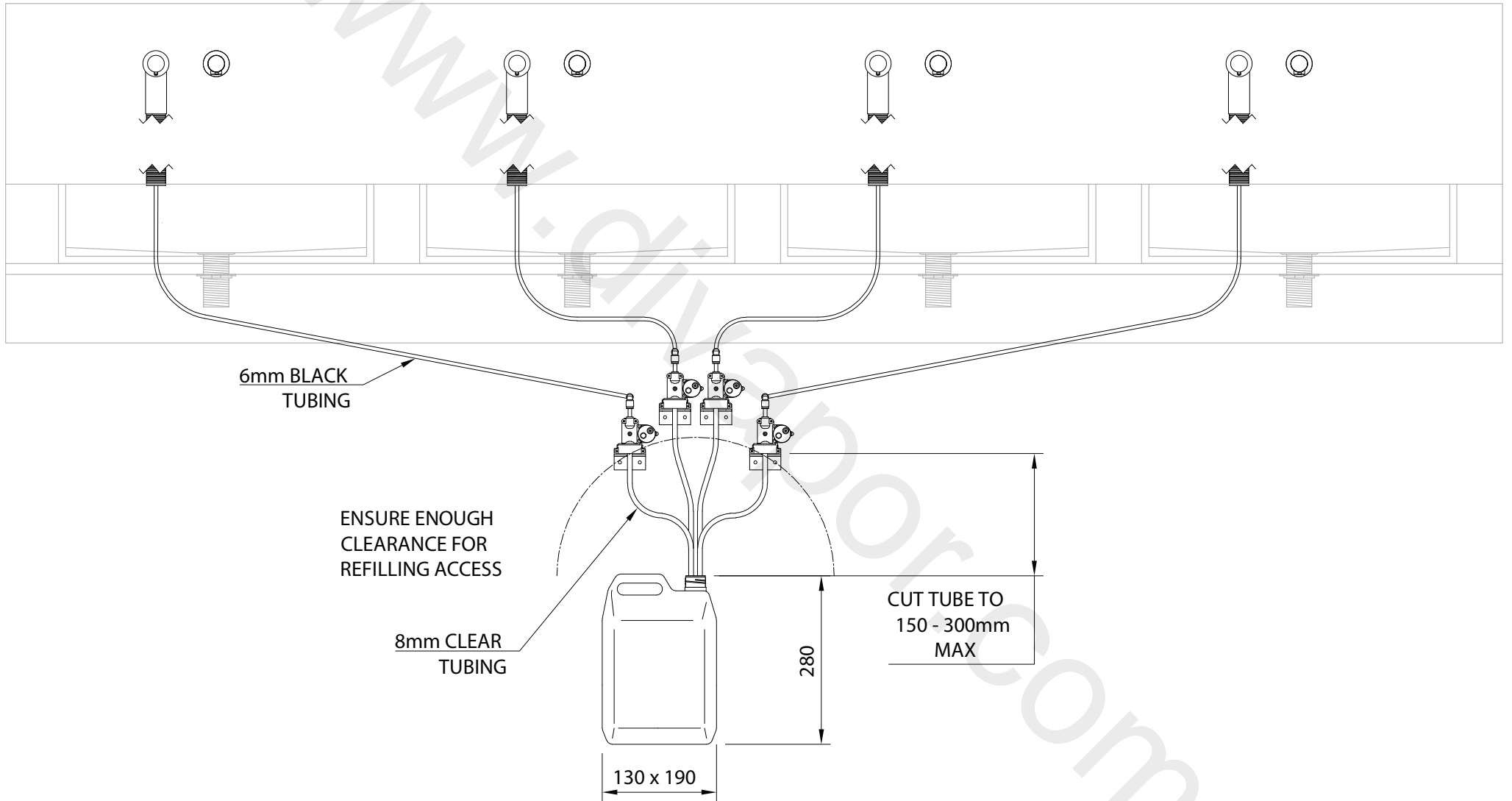



Request your 200 page
catalogue today on

01424 202224

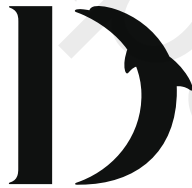

DOLPHIN

Dolphin Solutions Ltd

Southpoint, Compass Park, Bodiam, Robertsbridge, TN32 5BS

Tel: +44 (0)1424 20 22 24

Fax: +44 (0)1424 205 200

info@dolphinsolutions.co.uk

www.dolphinsolutions.co.uk