

INSTALLATION AND MAINTENANCE GUIDE

BC634

BEHIND FREE TOUCH FREE SOAP DISPENSER

Saving soap, saving power, promoting hygiene



Important:

Read carefully before installing product

D
DOLPHIN

INDEX

- 3 Technical Data
- 4 Pre-Installation Information
- 5 Pack Contents
- 6-8 Installation
- 9 Filling The Soap Tank
- 10 Settings Adjustment with a Remote Control
- 11 Batteries Replacement
- 12 Maintenance
Care And Cleaning Of Chrome And Special Finishes
- 13 Spare Parts List
- 14 Warranty
- 15 Trouble Shooting

TECHNICAL DATA

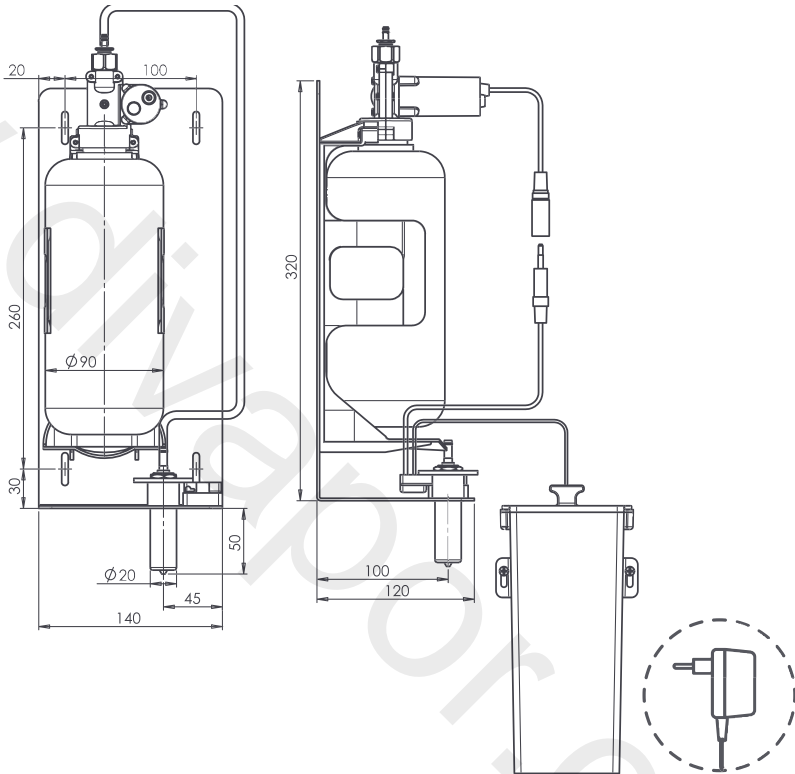

Behind mirror Soap Dispenser BC 634B

Behind mirror Soap Dispenser BC 634E

Capacity:	1 Litre \ 33.8 oz.
Power Supply:	IP 67 Battery Box for 6xD Alkaline batteries \ Transformer
Soap viscosity:	100 – 3800 cPs
Standard discharge:	0.8cc, Adjustable
Sensor range:	30-100 mm +/- 10 mm (Adjustable by remote control).

PRE INSTALLATION INFORMATION

Check contents

Separate all parts from the packaging and check each part with the "Pack contents" section.

Make sure all parts are accounted for before discarding any packaging material.

If any parts are missing, do not attempt to install your touch free soap dispenser until you obtain the missing parts.

Warnings

- 1) To avoid reflection problems keep a distance of more than 300 mm. between the sink and the spout.
- 2) This tap model, with an infrared sensor pointing down, is not intended to be used together with a sink of a reflective material such as stainless steel.
- 3) If a sink strainer is straight below the tap sensor, use a strainer with a non reflective finish (do not use a chrome plated one).
- 4) To prevent reflection problems, it is recommended to keep a minimum distance of 1.50 meters between the soap dispenser and any other objects.

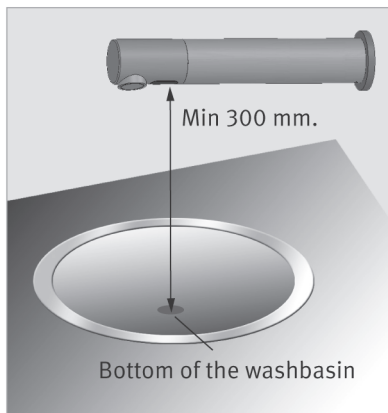

Important: Pay attention that the dimensions of the mirror compartment fits the dimensions of the Behind Mirror Soap Dispenser plate.

PACK CONTENTS

Familiarise yourself with the part names and confirm that the parts are included.



4 screws up to 5mm
(not supplied)

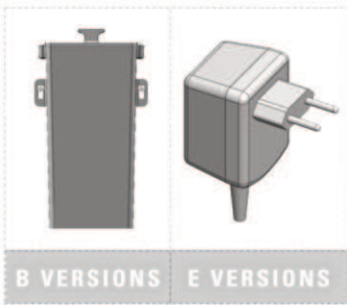

B VERSIONS

E VERSIONS

IP 67 Battery
box for 6 x D
alkaline batteries

Transformer

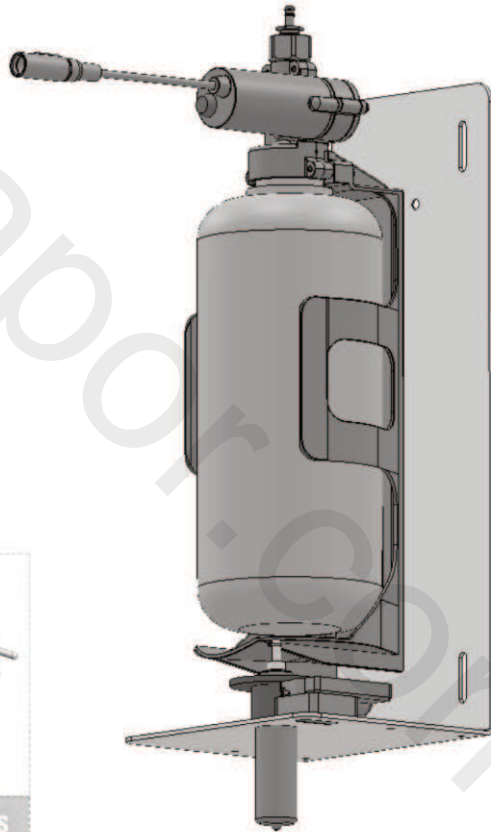

Product assembly containing: Pump
with bottle support, plate with spout
and soap tank

INSTALLATION

Step 1 : Preparation for installation

Cut a hole in the bottom of the mirror compartment for the soap dispenser sensor and spout both. The recommended hole size should be 30x50 mm.

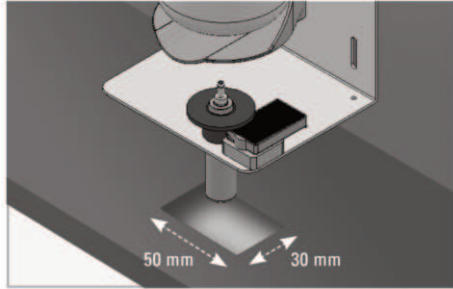

Step 2 : Installing the soap dispenser

1. Remove the protective sticker covering the sensor.
2. Place the soap dispenser assembly inside the mirror compartment with the spout sticking out of the hole.

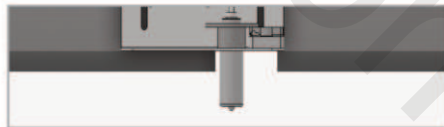
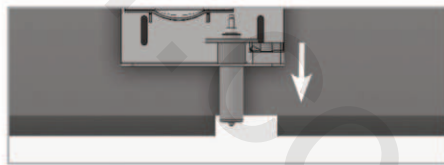
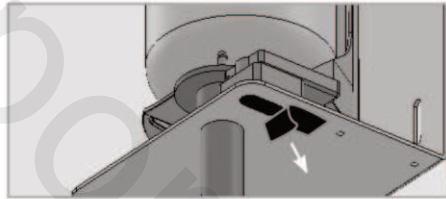

INSTALLATION

3. Secure the plate to the wall with 4 screws (not supplied).

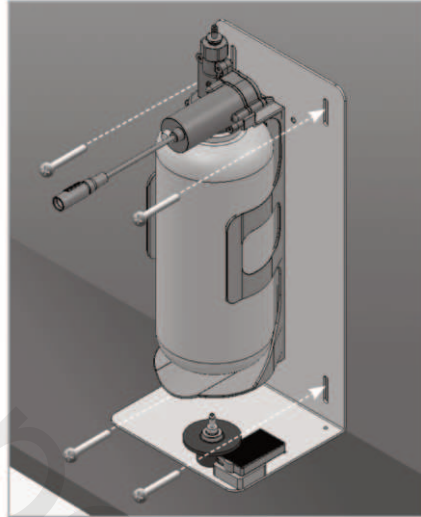

Step 3 : Connecting the power source

Make sure that the 4 contacts connector is connected properly so that the white o-ring is not visible.

Pay attention: If the 4 contacts connectors will not be connected properly, the motor will work continuously.



O-ring visible – not connected properly



Connected properly so that only the grooves are visible

INSTALLATION

For battery versions:

Install the battery box at the wall in the mirror compartment and connect the battery connector.

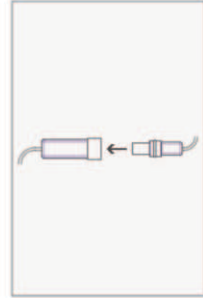
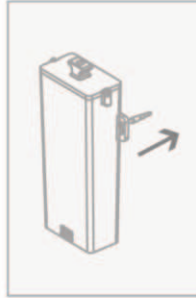

For transformer versions:

Plug the transformer into the electricity socket and make sure the transformer connector is connected.

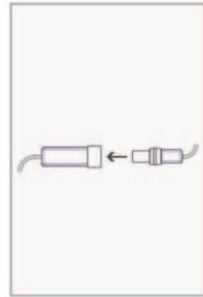
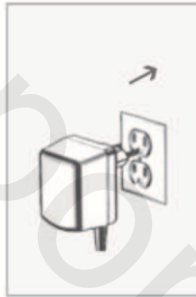

Wait about 10 seconds before you put your hands within the sensor range.



FILLING THE SOAP TANK

1. Unscrew the soap tank from the pump assembly.



2. Fill in the liquid soap up to the top line.



3. Insert the bottle with the tube inside the bottle support.

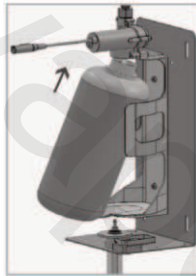

4. Screw the soap tank back to the pump assembly. Make sure the tank is secured firmly in place.

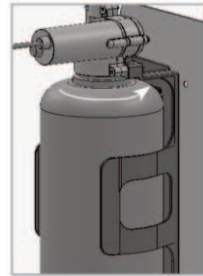

5. Press the refill button located at the back of the pump assembly until soap starts coming out of the soap dispenser spout. This operation can also be done using the soap dispenser remote control Refill function.



Note: Once the soap in the soap tank has reached the bottom line the soap tank should be refilled. To refill the soap tank please refer to steps 1-5.



SETTINGS ADJUSTMENT WITH A REMOTE CONTROL

If desired, use the remote control to adjust the soap dispenser settings. Hold the remote control straight in front of the sensor in a distance of about 4-6" (10-15cm).

Attention: Holding the soap dispenser remote control out of the recommended range (too close or too far) may interfere with the remote's activation.

Choose the function you want to adjust by pressing on the function button as following:

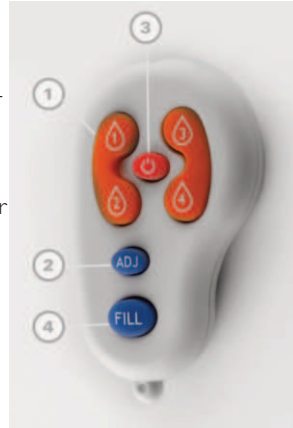

1 Soap Quantity

The 1-4 drop keys allow the user to choose the desired soap quantity.

Indication: continues blink of the red light in the sensor eye.

*The exact soap dosage depends on the soap viscosity.

1 0.2 to 0.4 2 0.7 to 0.9 3 1.2 to 1.6 4 2.1 to 2.3

2.ADJ

This function allows coming back to soap quantity factory settings. Press the ADJ button. Indication: 2 blinks of the red light in the sensor eye.

3 Temporary Off Function

This function is ideal to perform any kind of activity in front of the sensor without operating the system (for example, cleaning). The soap dispenser will remain shut for 1 minute when this button is pressed once. To cancel this function and to return to normal operation press the On/Off button again or wait 1 minute.

Indication: OFF – 2 fast blinks, ON – 4 fast blinks

4 Refill The Soap Tank

Once the soap tank has been refilled, press the FILL button. The pump would work for one minute in order for the soap to start coming out of the soap dispenser spout. To stop this activity press the FILL button again.

BATTERY REPLACEMENT

Battery models only

When the battery weakens, the red indicator light will blink at a constant rate when the user's hands are within the sensor range. The battery must be replaced within two weeks.

To replace the battery in battery models:

1. Carefully open the battery box place within the mirror compartment, using 2.5 mm Allen key
2. Remove the old batteries
3. Replace the used batteries with new D batteries

NOTE: Do not mix used batteries with new ones.

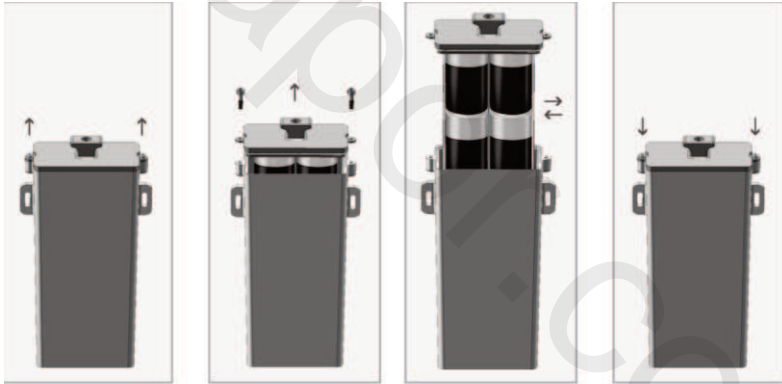

Important: Spent batteries should not be disposed of with normal household waste. Contact your local authority for information on waste disposal and recycling.



MAINTENANCE

Care and cleaning of chrome and special finishes

DO NOT use steel wool or cleansing agents containing alcohol, acid, abrasives, or the like. Use of any prohibited cleaning or maintenance products or substances could damage the surface of the soap dispenser. For surface cleaning use ONLY soap and water, then wipe dry with a clean cloth or towel. When cleaning bathroom tiles, the soap dispenser should be protected from any splattering of harsh cleansers.

SPARE PARTS LIST

Part Name	Part Code
Sensor kit	BC 07220230
Soap tank L	BC 07100020
Transformer	BC 06522042
Soap dispenser Pump assembly	BC 07222001
Remote control	BC 07100008
IP67 transformer box	BC 06530021
IP 67 Battery Box for 6xd alkaline batteries	BC 06530041
Bottle support L	BC 07120175
Soap dispenser spout assembly	BC 07271023

LIMITED WARRANTY

Filter cleaning instructions

The tap is provided with one stainless steel filter preventing foreign particles to enter the lines. If the water flow has decreased, this may be because the filter is clogged. The filter can be cleaned as follows:

1. Shut-off the water shut off valve.
2. Disconnect the water supply inlet from the adapter at the solenoid valve housing.
3. Remove the filter from the adapter and wash it under running water.
4. Reassemble the parts.
5. Reconnect the solenoid valve housing and restore the incoming water supply.
6. Make sure that there is no water leakage.

Care and cleaning of chrome and special finishes

DO NOT use steel wool or cleansing agents containing alcohol, acid, abrasives, or the like. Use of any prohibited cleaning or maintenance products or substances could damage the surface of the tap. For surface cleaning of tap use ONLY soap and water, then wipe dry with clean cloth or towel. When cleaning bathroom tile, the taps should be protected from any splattering of harsh cleansers.

TROUBLE SHOOTING

PROBLEM	INDICATOR	CAUSE	SOLUTION
No soap coming out of the spout	Red light in the sensor flashes continuously when the user's hands are within the sensor's range.	Low battery.	Replace battery.
		Soap has run low or completely out.	Refer to page 4 and refill the soap tank.
	Red light in the sensor flashes (once) and the motor is operating.	The soap tank has been filled but soap has not reached the spout.	Press the refill button located at the bottom of the pump until soap starts to come out of the spout again.
		The connectors between the motor and the power source are not connected properly.	Connect the connectors all the way through. Refer to page 7 to see how.
		Sensor is picking up reflections from the washbasin or another object.	Eliminate cause of reflection.
	Red light in the sensor does not flash (once) when user's hands are within the sensor's range.	Connectors between the electronic unit and the pump assembly \ transformer are disconnected or not properly connected.	Connect the electronic unit connectors to the pump assembly and transformer.
Battery is completely used up.		The battery must be replaced.	
Red light flashes (once) and the motor operates.		Soap solidification at the pipe.	Fill the bottle with hot water at 50/60C and run the pump constantly.
Soap coming out from the spout does not stop		The black connector between the pump assembly and soap dispenser are not connected all the way through.	Connect the black connectors all the way through.

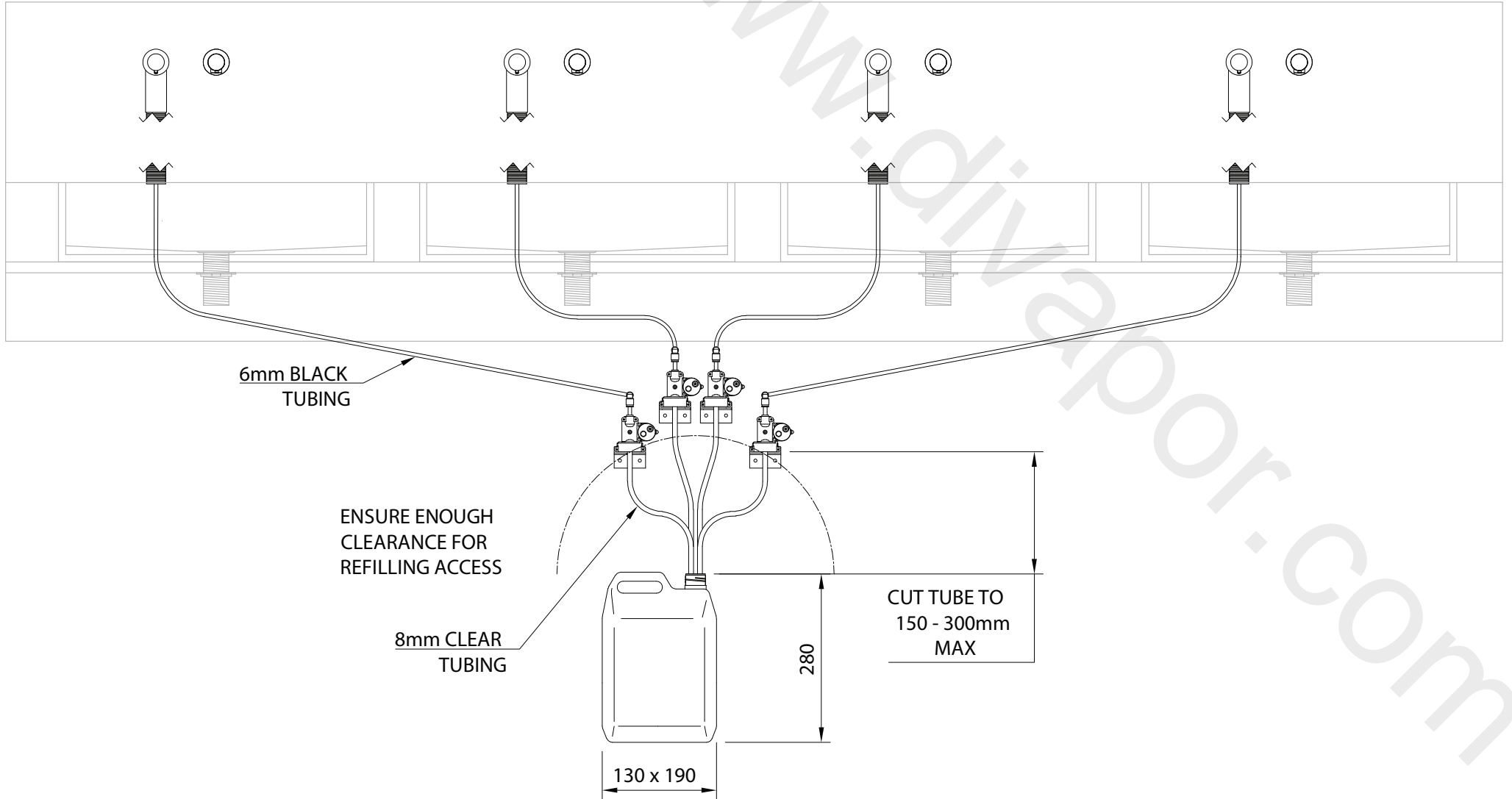



Request your 200 page
catalogue today on

01424 202224

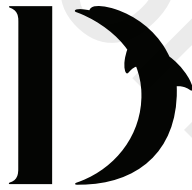

DOLPHIN

Dolphin Solutions Ltd

Southpoint, Compass Park, Bodiam, Robertsbridge, TN32 5BS

Tel: +44 (0)1424 20 22 24

Fax: +44 (0)1424 205 200

info@dolphinsolutions.co.uk

www.dolphinsolutions.co.uk