

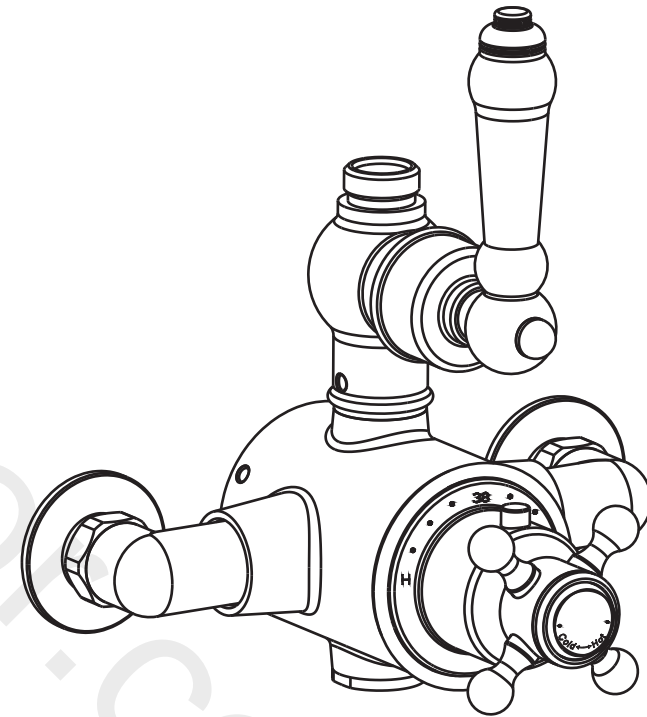

THE BATH CO
EXQUISITE BATHROOMS SINCE 2003

Traditional Exposed Valve Top Outlet



RBGRTXV01



Exclusively available @

VictoriaPlum.com

VictoriaPlum.com

Traditional Exposed Valve Top Outlet

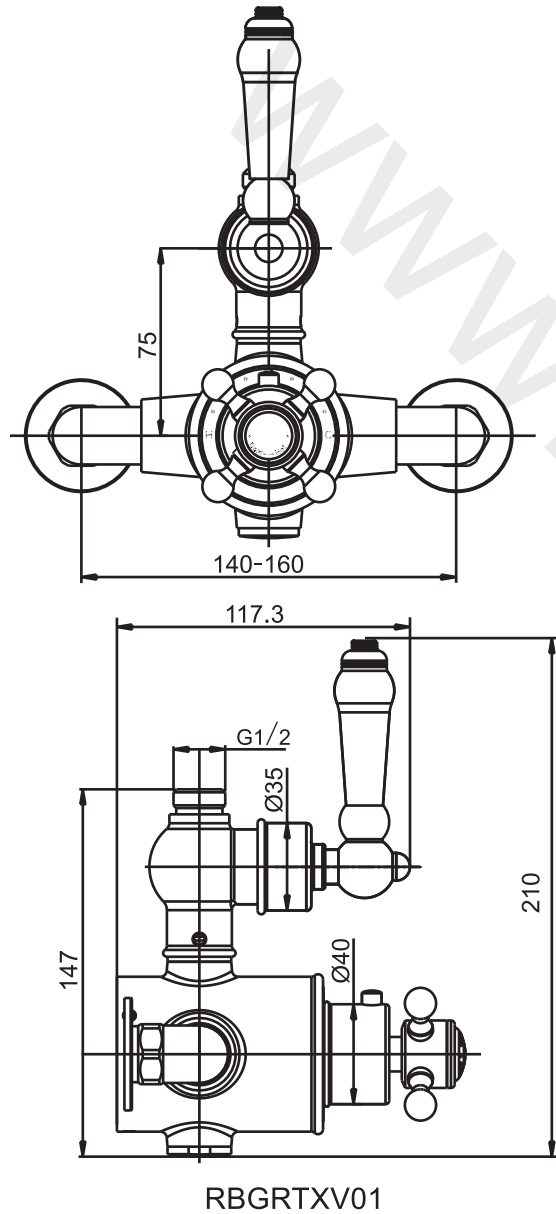

2. The defect is not due to use of an unsuitable or inadequate water or power supply.
3. The defect is not due to accident, misuse, neglect or repair other than by VictoriaPlum or VictoriaPlum authorised agents or damage caused by foreign objects or substances.
4. We have received from you the completed **Guarantee Registration Form when registered online**. VictoriaPlum accepts no responsibility for any forms lost in the post and returns by registered means is therefore recommended.

Under this guarantee (which is non-transferable) VictoriaPlum will, at its option, repair or replace free of charge any product (or replacement part) found to be defective. The guarantee does not extend to any consequential loss or damage. After repair or replacement the relevant guarantee period will be calculated from the original date of purchase.

All claims under the guarantee must be submitted in writing to the person who supplied the product to you and must be received no later than the last day of the relevant guarantee period. All claims must be accompanied by proof of purchase (sales receipt or delivery note).

VictoriaPlum operates a policy of continuous product development and therefore reserves the right to change the product, packaging and documentation specifications without notice.

This guarantee is in addition to and does not affect your statutory rights as a consumer.

3. Remove the cover cap (21) and screw (7), handle (22), stop ring (27) and collar (24,26). Using a hex spanner unscrew the brass ring securing the thermostatic cartridge.
4. Pull out the thermostatic cartridge (28).
5. Clean the filters by rinsing them in water and scrubbing with a fine brush to remove any debris and soaking them in vinegar or descaling agent.
6. Before re-fitting the cartridge, clean its housing with a wet cloth and grease the 'O' rings using a suitable WRAS approved silicone lubricant. Re-fit the cartridge in reverse order.
7. Make sure everything is tight and secure, turn on the water supply.
8. Now check the water temperature to ensure correct calibration and operation.
9. Replace the handle/screws/cover cap.

CLEANING

This product is made to the highest standard using high quality chrome plating and due care needs to be taken to ensure their looks are retained.

We recommend cleaning all products with a soft damp cloth ONLY and advise strongly against the use of ALL cleaning products i.e. powders and liquids.

If the above instructions are not followed this will invalidate your guarantee in the event of a problem occurring.

OPERATION SPECIFICATIONS

Hot Water Supply Temperature:

Maximum: 80° C (65° C recommended maximum)

Minimum: 55° C

Cold Water Supply Temperature:

Maximum: 25° C

Operating Pressure:

Maximum: 5 bar

Minimum: 0.2 bar

GUARANTEE

This product is guaranteed against manufacturing defects from the date of purchase until the expiry of the relevant guarantee period shown below.

The guarantee is only valid if:-

1. The product has been installed, used and maintained in accordance with VictoriaPlum instructions and subjected to normal use only.

PLEASE LEAVE THE INSTRUCTIONS WITH THE END USER

IMPORTANT INFORMATION

This guide provides instructions for the installation and maintenance of the Thermostatic Shower Valves. It is beyond the scope of this guide to provide detailed instructions for the installation of auxiliary products which may be attached to these valves. Please consult your installer and any guides which are provided with those products.

Remove all packaging and check the product for missing parts or damage before starting installation.

Any alterations made to this product and fittings may infringe water regulations and will invalidate the warranty.

The installation must comply with all Building and Plumbing Regulations and Local/National Water Supply Authority Regulations/Byelaws.

We strongly recommend that you use a qualified and registered plumber.

IMPORTANT: Failure to comply with the installation and commissioning instructions as detailed will invalidate the product warranty.

This thermostatic mixing valve range has been specifically designed and manufactured to meet the requirements of BS EN 1111. The valves have been independently tested and approved as a TYPE 2 valve under the TMV scheme.

These thermostatic valves are suitable for any water system. Where instantaneous heaters are used, the flow of hot water required to initiate and continue burning must reach the minimum switch-on flow rate of 3 litres per minute. At flow rates between 3 and 8 litres per minute, the appliance must be capable of raising the water temperature to a minimum of 52°C.

Water supplies must be reasonably balanced. For best performance within 0.2 bar.

Where connections are made to the mains cold water supply, WRC approved single check valves must be fitted to both hot and cold inlets. This is a stated requirement of Water Supply (Water Fittings) Regulations 1999 Schedule 2, Section 15.

The Installation of full flow isolating valves to the inlet feeds is recommended.

Before making any inlet pipe connections, all supply pipes MUST be thoroughly flushed to remove debris. Failure to do so could invalidate the warranty and result in damage or low flow from the mixer unit. Water Supply (Water Fittings) Regulations 1999 Schedule 2 Section 13.

Please take great care when installing this mixer not to damage its surface finishes.

IMPORTANT: When water pressure is above 5 bar a pressure reducer is required to be fitted before the valve. Pressures above this maximum may invalidate the warranty.

Please note if installing in an enclosed environment, access should be left for servicing and maintenance. No costs relating to inadequate access can be accepted.

INSTALLATION NOTES

The installation of thermostatic mixing valves must comply with the requirements of the Water Supply (Water Fittings) Regulations 1999.

Turn off the water supply before carrying out any works on the pipe work. Please check for any hidden cables and pipes before drilling holes in the wall. Before installation ensure that the designation of the valve matches the application, flow rates, dynamic pressures and temperatures within the limits stated. It must be installed in such a position that maintenance of the thermostatic

cartridge and its valve and the testing and commissioning of the thermostatic cartridge can be undertaken.

The valve must not be installed until the water system has been completely flushed free of all debris.

The installation of full flow isolation valves is recommended as close as possible to the water supply inlets of the valve.

The thermostatic cartridge contains temperature sensitive components hence soldering or heating near the valve body must be avoided.

Rinse pipe work carefully before fitting the valve: do not allow dirt, metal particles or shavings to block the filters fitted on inlets as damage may occur to the internal components.

PREPARATION AND INSTALLATION

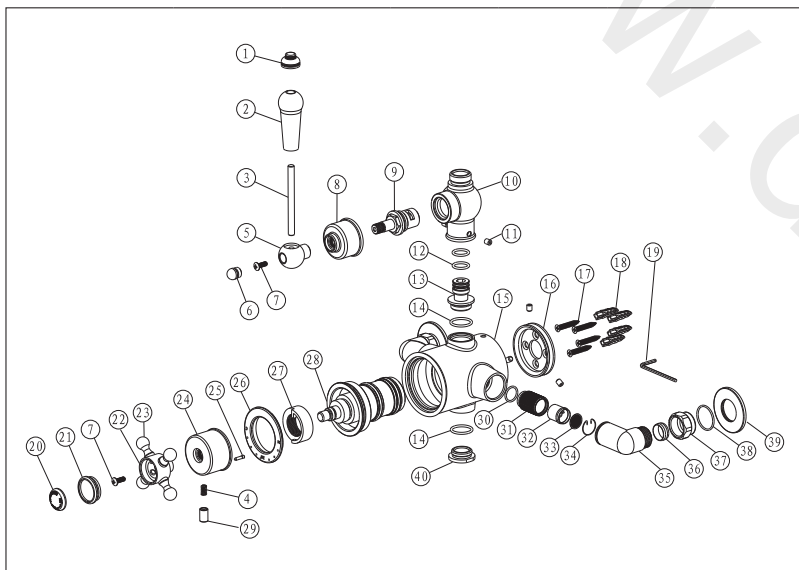

1. Determine the final installation position and installation height as per the dimension drawing above.
2. Prepare the water supply pipes (hot on the left and cold on the right) at the identified height with a width of 150mm centres. Make the ends of pipes 20-25mm out from the face of the wall (it may be necessary to cut these slightly prior to final connection).
3. Put the shower valve against the wall and mark the position of the valve body. Using this mark as a guide mark 4 x fixing holes for the mounting plate (16). Drill 4 x holes in the wall then insert the plastic wall plugs (18) and attach the mounting plate (16) using the supplied screws (17). Ensure the plate is firmly attached to the wall.
4. Fit parts (36,37,38,39) then push the shower valve connection (35) over each pipe and connect.
5. Finally screw the grub screws into the valve body and firmly onto the mounting plate (16).

6. If supplied install the riser into the shower valve and install the wall bracket onto the wall to hold the riser. Insert the shower arm into the riser and fit the shower head onto the shower arm.
7. Check that all connections are tight.
8. Turn on the water supply and test all pipe work.
9. Isolate the water supply and remove hot and cold check valves and filters located in the water inlets (35) to the valve. Flush out and re-fit.
10. The thermostatic cartridge is factory set. To ensure correct operation check the temperature of the water taken at the normal flow rate after allowing for the water supply system to stabilise. The sensing part of the thermostatic probe used to test the water temperature must be fully submerged in the water that is to be tested.
11. Set the temperature at the recommended 38 deg. C or as required. To change the temperature turn the control spindle anti-clockwise for hotter, clockwise for colder.

MAINTENANCE

We recommend that the below is carried out on an annual basis as failure to do so may result in invalidation of warranty.

CHECK VALVES

1. Isolate the hot and cold water supply.
2. Remove both check valves located in the water inlets (35) to the valve.
3. Rinse in water to remove any debris, and then if necessary soak them in vinegar or descaling agent.
4. Dry and lightly grease the 'O' rings using a suitable WRAS approved silicone lubricant and replace.

THERMOSTATIC CARTRIDGE

To clean the thermostatic cartridge you must first remove the cartridge from the housing.

Removing the thermostatic cartridge

1. Isolate the hot and cold water supply.
2. Mark the position of the thermostatic handle using a marker pen.