

### *Using The Safeguard+ Remote Start/Stop*

#### **To start the shower using the remote**

Press the Remote Start/Stop button and immediately the shower will activate and water will begin to flow. An audible bleep will be heard from the shower upon start up (if option is selected.)

#### **To stop the shower using the remote**

Press the Remote Start/Stop button. An audible bleep will be heard from the unit and water will cease to flow.

(If the timed shutdown option is selected 1 bleep will be heard to inform the user that they have 1 minute of showering time remaining. Finally 5 bleeps will sound to alert the user to the end of the showering time before the unit switches off.)

### *Cleaning The Safeguard+ Remote Start/Stop*

Do not use abrasive or solvent cleaning fluids. The Remote Start/Stop should be cleaned using a soft cloth and warm water.

# Installation Instructions

## Electrical Connections Of The Safeguard® Remote Start/Stop

### ELECTRICAL CONNECTIONS

#### CABLE ROUTING.

**Fig.2** shows a schematic wiring diagram displaying the alternative routes the control cable can take to exit the remote. The control cable can exit through three points at the base of the remote and one at the top. Alternatively a hole can be drilled into the wall allowing the remote to be wired from behind (**Fig.4**).

#### ⚠ WARNING ⚠

Remote Start/Stop **MUST** be secured to the wall. The control cable should either be surface clipped, hidden via trunking conduit or concealed in the wall.

**DO NOT** Route cable in contact with 240V mains cable.

#### SHORTENING THE CONTROL CABLE.

The Triton Remote Start/Stop is supplied with a 5m control cable to allow for a varied choice of positioning. However if you wish to shorten the cable you can.

**Note:** If shortening the cable please remove the excess from the middle section (**Fig.3**). **DO NOT** shorten the cable between the connector (1) and the suppression (2). When shortening the cable please ensure that the cable colours are rematched. Failure to do this will impair the operation of the shower and will also invalidate the guarantee.

**Fig.2**

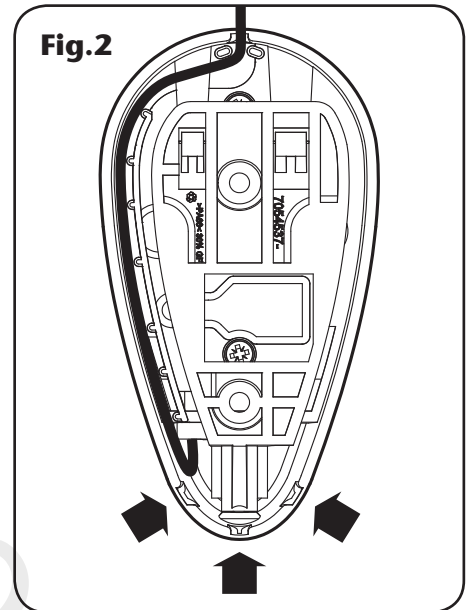

#### SITING OF THE REMOTE

Product is IPX4 rated and therefore can be sited in Zone 1.

#### ⚠ WARNING ⚠ COVER RETAINING SCREW

**ONLY** the SUPPLIED SCREW should be used. The use of none supplied screw **WILL** invalidate product specifications & warranty.

**Fig.3**



## Installing The Safeguard® Remote Start/Stop

**Fig.4**

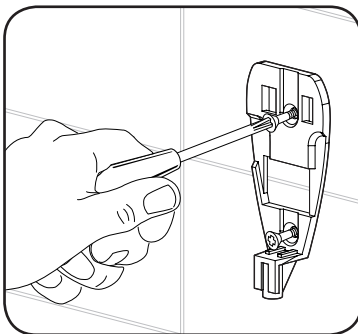

**Fig.5**

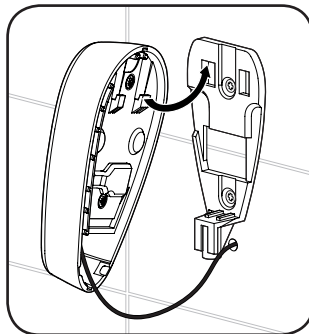

**Fig.6**

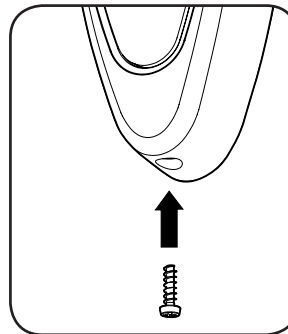

**Fig.7**

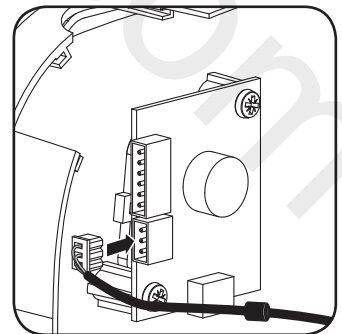

### FITTING THE CONTROL PANEL BRACKET

1. Mark the two holes using the wall bracket as a guide before drilling and plugging the holes using suitable fixings. Make sure the wall bracket is securely held in place before continuing.

**Note:** The mounting bracket must be fitted on the surface of the tiles (**Fig.4**).

2. Once you have selected your chosen cable routing using **Fig.2** attach the Remote Start/Stop to the bracket as shown in **Fig.5**.
3. Locate the fitting tabs on the back of the Remote Start/Stop with the corresponding slots in the wall bracket. Then simply slide the remote upwards to locate over the screw housing.
4. Assemble the remote to the wall bracket at the base using the screw provided (**Fig.6**).
5. Finally plug the control cable into the socket provided on the PCB housed in the back of the shower cover. (**Fig.7**)

**IMPORTANT:** Leave enough free play in the cable to allow for future removal of the remote for servicing purposes.

**DO NOT** switch on the electricity supply until the remote is housed on the wall using the bracket.

Triton Showers  
Triton Road  
Nuneaton  
Warwickshire CV11 4NR

Triton is a division of Norcross Group (Holdings) Limited

Customer Service: ☎ 0844 980 0750

Trade Installer Hotline: ☎ 0844 980 0730

Fax: 0844 980 0744

[www.tritonshowers.co.uk](http://www.tritonshowers.co.uk)

E-mail: [serviceenquiries@tritonshowers.co.uk](mailto:serviceenquiries@tritonshowers.co.uk)

**Extended Warranty AVAILABLE NOW. Call 0844 980 0740 for more details.**