

TECHNICAL DATA SHEET

nabis
showering

TWIN

TWIN THERMOSTATIC SURFACE MOUNTED SHOWER VALVE WITH
DIVERTER & FAST FIX CONNECTIONS

Product Specification

Product Code:	D01192
Finish:	Chrome
Product Type:	Contemporary
Construction:	Body is of brass construction
Cartridge Type:	Thermostatic cartridge
Supply:	Suitable for all plumbing systems, preferably balanced
Inlet Connection:	15mm compression
Water Pressure:	Min 0.5bar, Max. 5.0bar
Dimensions for Fitting:	150mm inlet centres

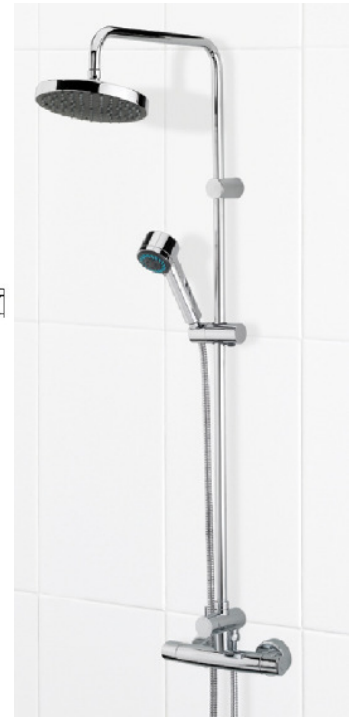
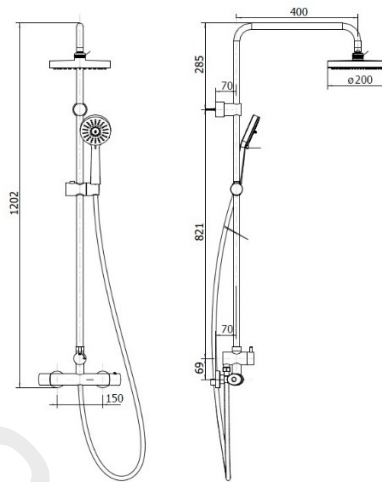

Additional Information

- Dual control – flow and temperature are controlled separately, giving accurate control of both.
- Thermostatic cartridge maintains showering temperature to +/- 1°C by compensating for changes in the incoming water temperature and pressure giving the stable outlet temperature.
- Automatic shut off in the event of hot or cold water supply failure, thus reducing the risk of scalding.
- Factory set to a maximum of 38°C to eliminate the ability to select an unsafe temperature – this can be manually over-ridden up to 46°C to suit user preference.
- Supplied with 1.5m hose, single function handset and 200mm rose, both with rub clean nozzles.
- Chrome plated to BSN 248.

Technical Advice: For further information please call 0844 811 7658 or visit www.wolseley.co.uk
Guarantee: 5 years covering manufacturing faults.

Flow Rates (litres per minute)

System Pressure	0.6bar	0.8bar	1bar	2bar	3bar	5bar
Through shower rose	6.5	7.5	8.6	12.4	15.2	19.7
Through handset	6.2	7.3	8.2	11.9	14.9	19.6

Wolseley UK Ltd
Warwickshire
CV31 3HH
www.wolseley.co.uk

D5



The information contained on this page was correct at date of issue. Fitting dimensions are provided as a guide only. Some variation may occur due to manufacturing tolerances. We pursue a policy of continuing improvement in design and performance of its products and so reserves the right to change specifications without prior notice.