



DP1510

## **DOLPHIN LIQUID SOAP AND DISINFECTANT SENSOR DISPENSER**

USER GUIDE FOR MAINTENANCE AND CARE

## CONTENTS

---

Open and close housing	6
Refill tank	6
Replace disp. bottle	7
Change batteries	8
Change pump	9
Change eModule	10
Check function	11
Contact us	12

# SAFETY INFORMATION

## Operating fluids and cleaning agents can cause skin and eye irritation or damage.

- ▶ Always wear protective gloves.
- ▶ Keep operating fluids and cleaning agents out of eyes.
- ▶ Observe the safety information on the packaging of the operating fluids and cleaning agents.

## Troubleshooting

The dispenser only works when installed and, if applicable, when the housing is closed (surface-mounted dispensers).

Fault/LED signal	Cause	Solution
LED flashes red slowly	Batteries almost empty	▶ Change batteries
LED flashes red quickly and dispenser inoperative	Pump jammed	▶ Clean pump, replace if necessary
LED lights up red and dispenser inoperative	Batteries empty	▶ Change batteries
LED lights up orange and dispenser inoperative	Incorrect battery polarity	▶ Insert batteries correctly
LED is not illuminated and dispenser inoperative	Magnet in the housing or in the pump bracket is missing or pump bracket is bent	▶ Replace magnet or align pump bracket
	Batteries missing	▶ Insert batteries
	Plug-in power supply not plugged in correctly	▶ Insert the plug as far as it will go
	No power or plug-in power supply defective	▶ Alternatively, insert batteries If the dispenser is working: ▶ Check power connection ▶ Replace power supply if necessary
	Module not positioned correctly in rear panel	▶ Insert the Module properly (see page 24)

<b>Fault/LED signal</b>	<b>Cause</b>	<b>Solution</b>
Dispenser triggers sporadically without actuation	Interference due to mains supply line or static charge	<ul style="list-style-type: none"> <li>▶ Switch to battery operation</li> <li>▶ Check interference in the power grid and rectify if necessary</li> </ul>
Dispenser triggers continuously without actuation	Sensor dirty	▶ Clean sensor window (see User Guide für Mounting and Commissioning: Module)
	Heavily soiled dispenser	<ul style="list-style-type: none"> <li>▶ Clean dispenser</li> <li>▶ If this does not rectify the fault: Replace Module</li> </ul>
Dispenser triggers unreliably when actuated	Module not inserted correctly in rear panel	▶ Insert Module and pump properly (see page 24)
Soap leaks out	Pump jammed	▶ Check soap pump for ease of movement and replace if necessary
	Disposable soap bottle/tank leaking	▶ Replace disposable bottle with cap or tank

## Cleaning and care

- ▶ Observe the information and regulations on occupational safety and environmental protection as well as the usage instructions for the cleaning agents used.
- ▶ To avoid damage to the stainless steel surfaces, the following aids and cleaning agents must **NOT** be used:
  - Abrasive cleaning powder or abrasive pastes
  - Knives or scrapers
  - Ferrous scouring sponges, steel brushes or steel wool
  - Chloride-containing products, especially hydrochloric acid and other acidic products (only exception: vinegar-based cleaning agents)
  - Bleach
  - Silver polish
- ▶ When cleaning the dispenser, observe the information in the table below.

# Cleaning instructions for stainless steel surfaces:

Soiling	Recommended cleaning agent	Recommended cleaning utensil
Fingerprints, dust	<ul style="list-style-type: none"> <li>– Washing-up liquid solution</li> <li>– Commercially available stainless steel or vinegar-based cleaning agent</li> <li>– Glass cleaner<sup>1)</sup></li> </ul>	<ul style="list-style-type: none"> <li>– Damp cloth or leather</li> <li>– Dry cloth for buffing</li> </ul>
Soap residues inside or outside	<ul style="list-style-type: none"> <li>– Water</li> <li>– Vinegar-based cleaning agent</li> </ul>	<ul style="list-style-type: none"> <li>– Damp cloth</li> </ul> <p><b>CAUTION:</b> Never clean the Module under running water!</p>
Limescale	<ul style="list-style-type: none"> <li>– Household cleansing milk</li> <li>– Vinegar-based cleaning agent</li> <li>– Clean water for rinsing</li> <li>– Deionised water for aftertreatment</li> </ul>	<ul style="list-style-type: none"> <li>– Damp cloth</li> <li>– Non-ferrous cleaning sponges</li> <li>– Dry cloth for buffing</li> </ul>
Oil, grease	<ul style="list-style-type: none"> <li>– Alcoholic cleaning agents</li> <li>– Solvent-based cleaning agents (e.g. methylated spirits, isopropyl alcohol, acetone)</li> </ul>	<ul style="list-style-type: none"> <li>– Repeated cleaning with cloths freshly dampened each time</li> </ul>
Heavily neglected surfaces	<ul style="list-style-type: none"> <li>– Polishes (e.g. chrome care polish)</li> </ul>	<ul style="list-style-type: none"> <li>– Damp cloth</li> </ul>
Signs of age (e.g. surface rust)	<ul style="list-style-type: none"> <li>– Special-purpose stainless steel cleaning agents containing phosphoric acid</li> </ul>	<ul style="list-style-type: none"> <li>– Damp cloth</li> </ul>

<sup>1)</sup> Applies to reflective stainless steel surfaces

## Disposal



This symbol on the product, in the guide or on the packaging means that the electrical and electronic equipment must be disposed of separately from household waste at the end of its life.

- ▶ Always dispose of used equipment in accordance with the applicable regulations.
- ▶ Dispose of batteries separately from the product after use in accordance with the applicable regulations.

## OPEN AND CLOSE HOUSING

For surface and flush mounted dispensers only.

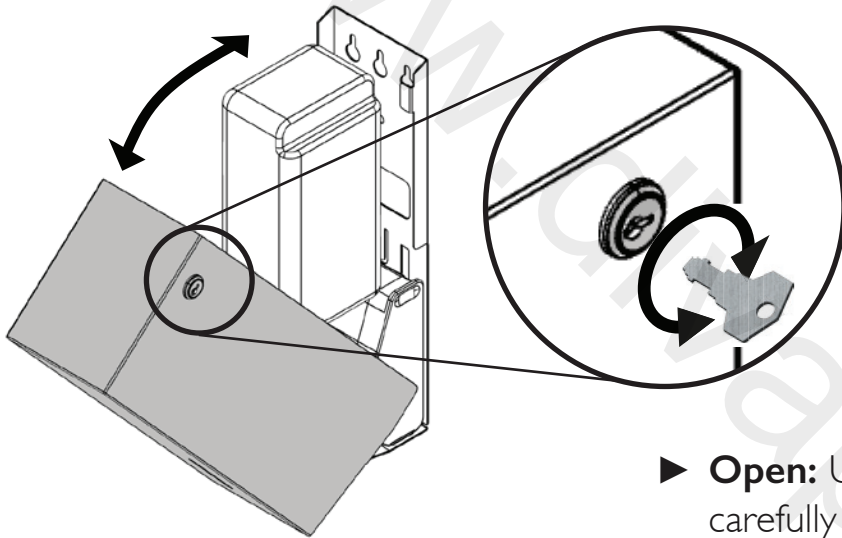

- ▶ **Open:** Unlock the lock with the key and carefully open the housing.
- ▶ **Close:** Close housing as far as it will go, lock it and remove the key. The key can only be removed in the closed state.

## REFILL TANK

For dispenser with tank only.

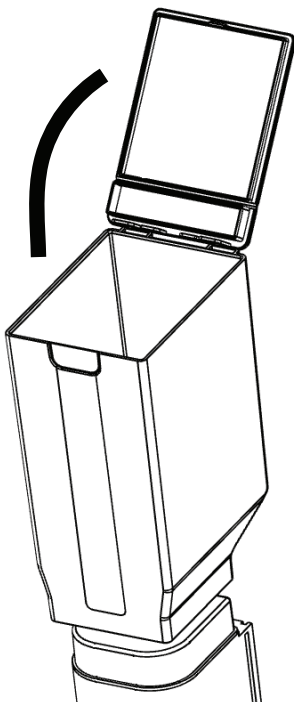

- ▶ **NOTICE:** Fill only with the operating medium intended and suitable for the dispenser (see Requirements for operating fluids“
- ▶ Open tank cap and fill in liquid soap or disinfectant.
- ▶ Close cap and remove any spilled liquid

## REPLACE DISP. BOTTLE

The disposable bottle is not intended for refilling.

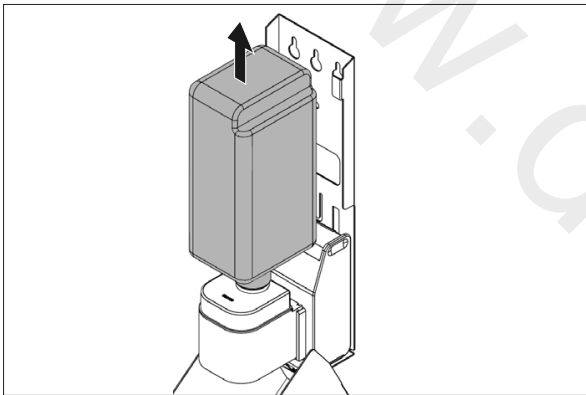

▶ **Open housing and check filling level.**

▶ **Bottle is empty**

Pull out empty bottle straight upwards.

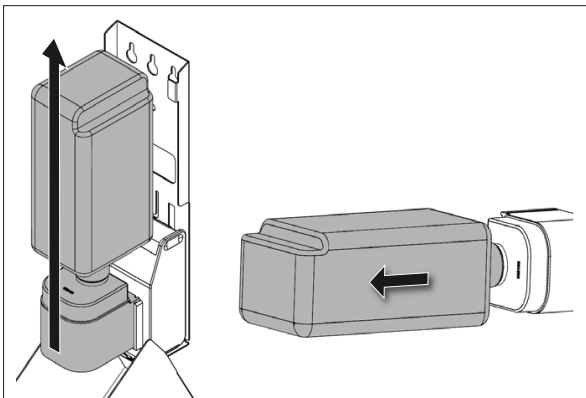

▶ **Residual liquid in the bottle:**

Pull out bottle and pump **together** upwards, hold them horizontally over a sink and pull bottle carefully off the pump.

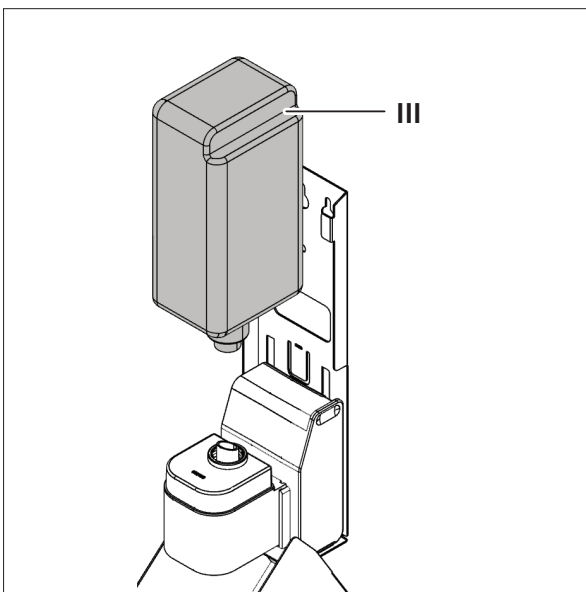

▶ **Insert a new bottle**

-Place bottle into pump connection and rotate it in straight until it stops.  
Dispenser for surface mounting: Indentation in end position right (III).

-Clean up any spilled liquid (see “Cleaning and care“ on page 9 or your language).

## CHANGE BATTERIES

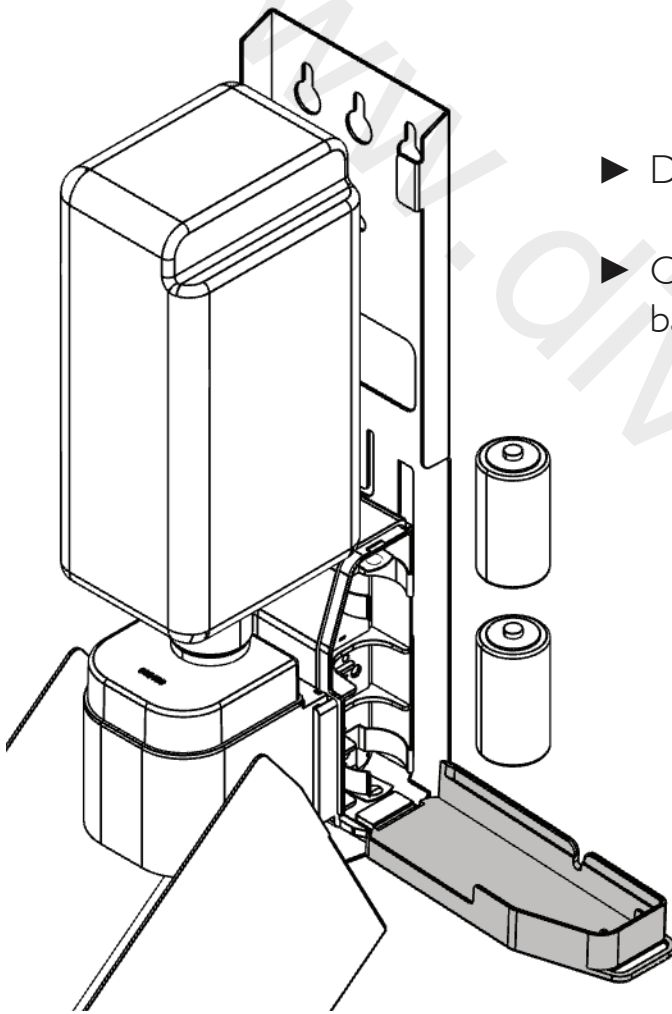

- ▶ Do not use rechargeable batteries.
- ▶ Observe the notes on the disposal of batteries on page 10 (or your language).

1. Open battery compartment cover on the right hand side of the Module and remove batteries.
2. Insert new batteries (type Baby C LRI4) into battery compartment with the positive pole facing upwards.
3. Close battery compartment cover.
4. For troubleshooting see “Troubleshooting” on page 8 (or your language).
5. Observe the notes on the disposal of batteries on page 10 (or your language).



## CHANGE PUMP

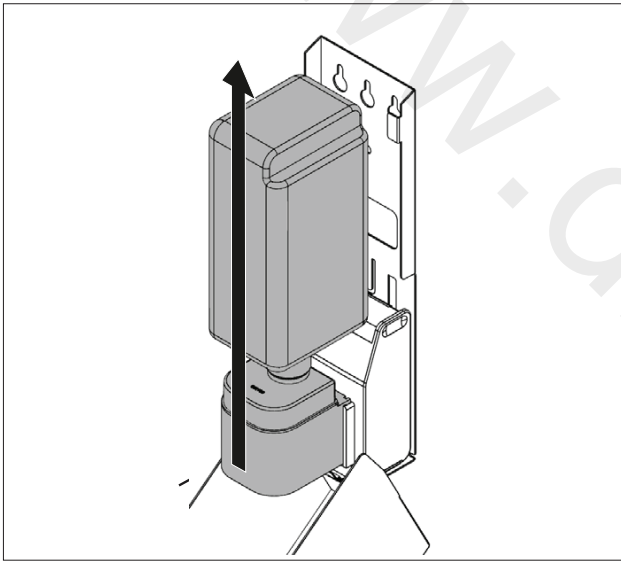

- ▶ **To avoid spilling residual soap in the dispenser:** Pull out the pump and, if applicable, the bottle/plug-in tank together upwards.

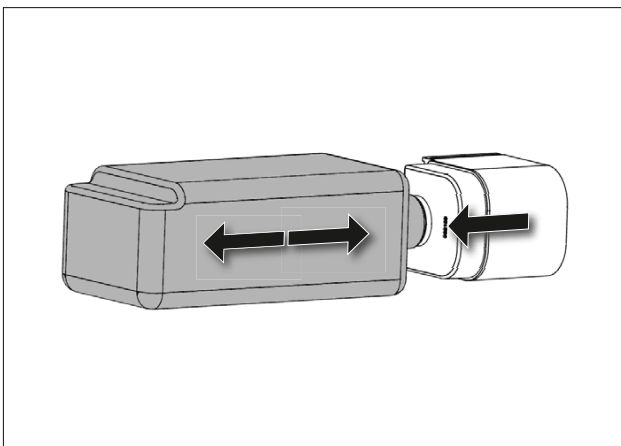

- ▶ Hold the pump and the bottle/plug-in tank horizontally over a sink and remove the bottle from the pump.
- ▶ If applicable, first hold the new pump horizontally over a sink, insert the bottle/plug-in tank on the pump mandrel and screw it in straight as far as it will go.

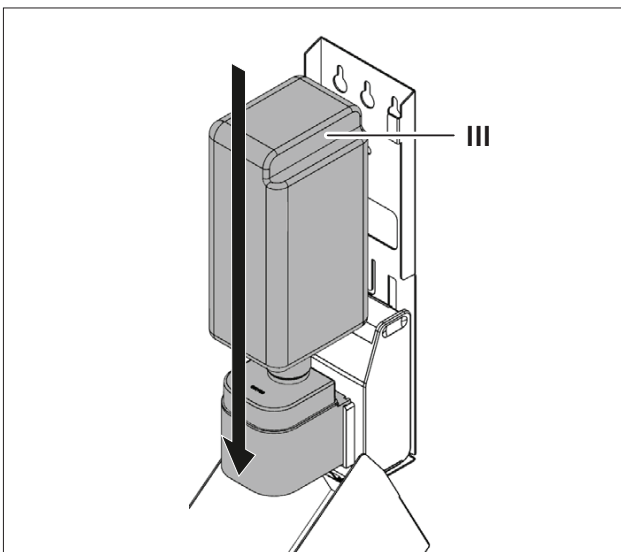

- ▶ Insert new pump into the Module.  
Dispenser for surface mounting:  
Note the indentation on the right (III).
- ▶ Clean up any spilled liquid (see „Cleaning and care“ on page 9 or your language).

## CHANGE MODULE

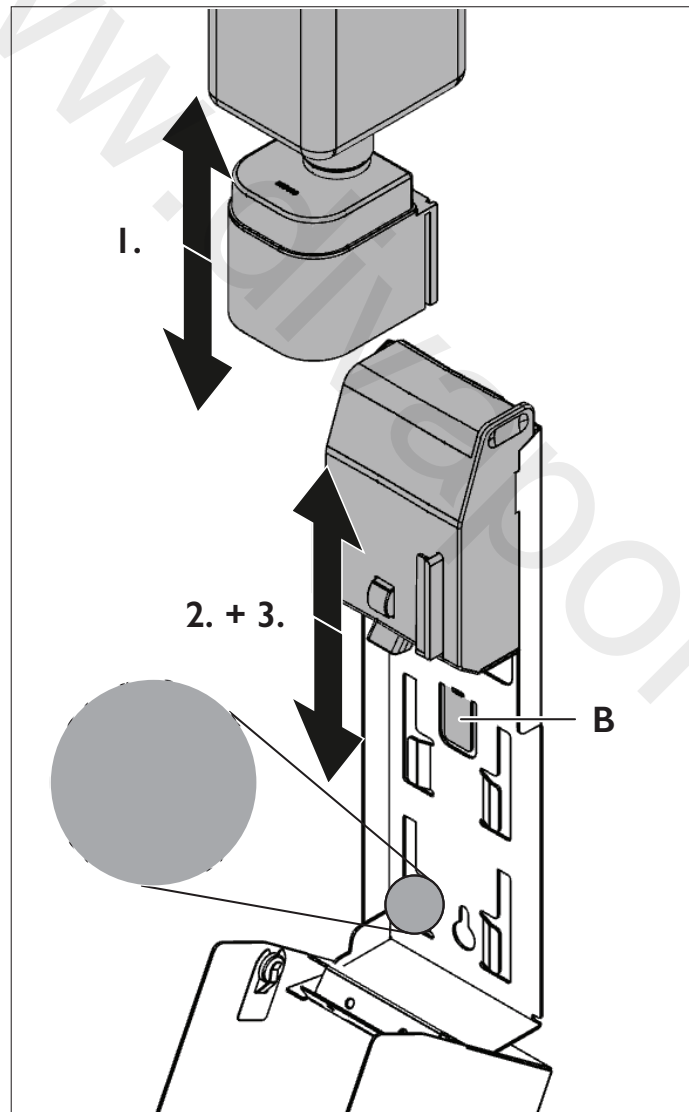

1. Pull out the pump together with the tank or disposable bottle upwards.
2. Press securing tab (B) to unlock Module and pull it out upwards.
3. From the top slide new Module into all four tabs of the back plate.
4. Bend the securing tab (B) forward again.

## CHECK FUNCTION

With surface-mounted devices, the dispenser only works when the housing is completely closed.

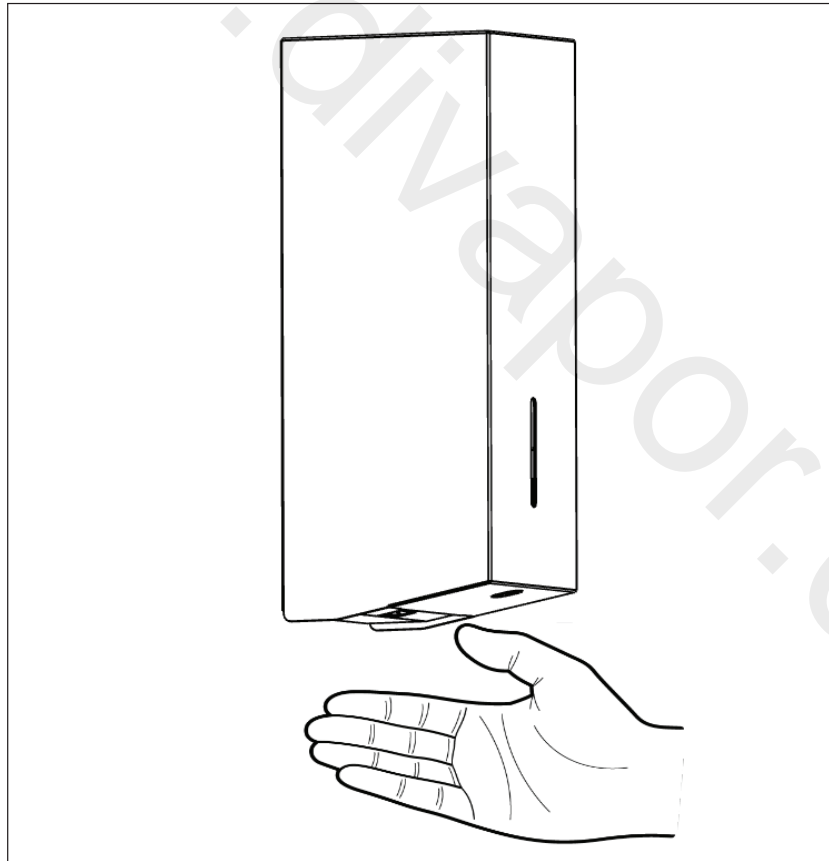

- ▶ Hold your hand under the dispenser so that the Module triggers the pump. After changing the pump, several actuations may be required until liquid is dispensed.
- ▶ For combinations, test all modules individually.
- ▶ For troubleshooting see “Troubleshooting“ on page 8 (or your language).



## CONTACT US

Dolphin  
Southpoint, Compass Park  
Junction Road, Bodiam  
TN32 5BS  
United Kingdom

T +44 (0)1424 202 224  
info@dolphinsolutions.co.uk  
W [dolphinsolutions.co.uk](http://dolphinsolutions.co.uk)

© Dolphin Solutions Ltd.