

INSTALLATION INSTRUCTIONS

Greenwich Tall Basin Mixer

GRE.112

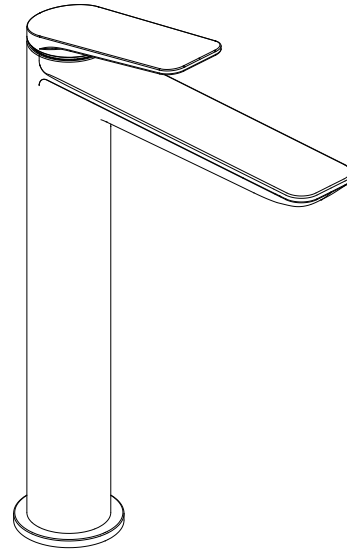

Important

- We recommend that this product is installed by a qualified professional contractor. Such as a plumber who is certified by NVQ (National Vocational Qualification) or SNVQ (Scottish National Vocational Qualification) Level 3.
- Please check this product immediately to ensure that it has not been damaged and is complete. Before installation, please make sure this product is the correct model and you have all the parts required for installation and using.
- All the taps should be supplied with hot and cold water at balanced pressure. If not, then the mixing function will not work correctly. It is necessary to fit non-return valves on both hot and cold feeds pipe. These are not supplied.
- Please flush the water system to ensure that no metal swarf, solder, and other impurities can enter the taps.
- Turn off water supply before commencing work, this should be done at the isolating valves of inlet feeds if fitted or main stopcock.
- Please read these instructions carefully and keep it for future reference.

Working pressure

The tap is suitable for both high and low pressure installation. The suggested minimum operating water pressure is 0.5 bar. The suggested maximum operating water pressure is 5 bar. Where the operating water pressure is above 5 bar, then a pressure reducing valve must be fitted.

Aerator

Taps are all fitted with a aerator.

Please use the key to remove aerator from spout if required.

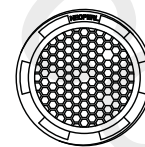

AERATOR

Cleaning

Before use: Unscrew the aerator and allow the water to run freely for 5 minutes. Then screw the aerator back in place.

Periodically: Unscrew the aerator and remove. Rinse it with running water until any loose debris is cleared. Then replace the aerator and tighten.

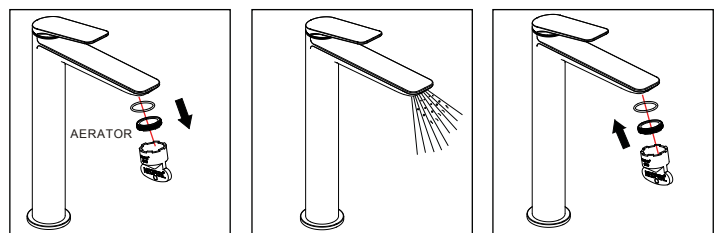

Maintenance

We do NOT recommend you use any household cleaners to clean the product. Because these cleaners change substance or formula too frequently. The product should be always cleaned only with soapy water and rinsed with clean water and dried with a soft cloth.

Dimension

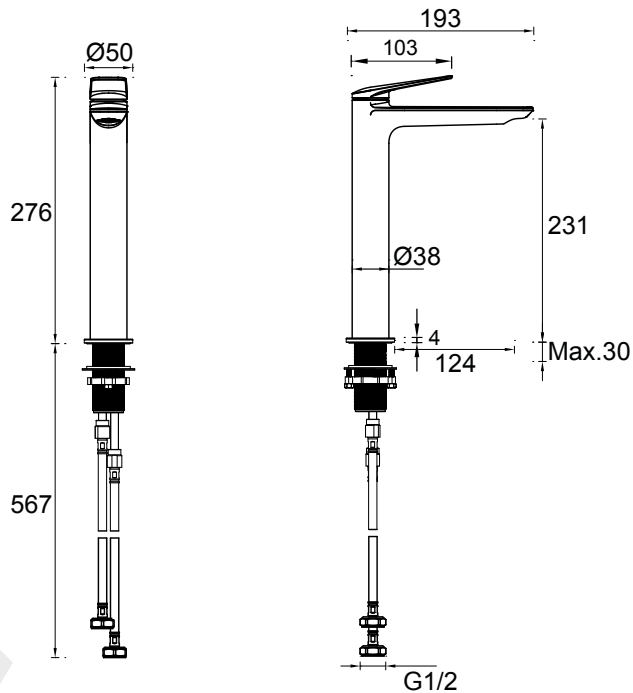

Installation

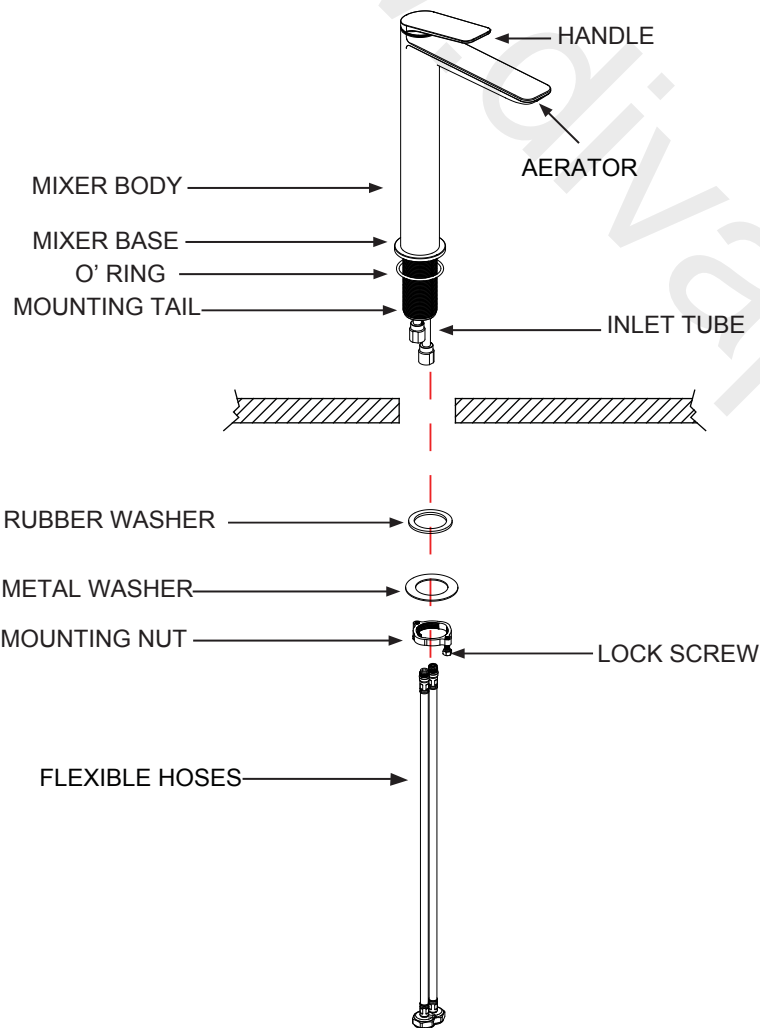

- 1: Fit the O' ring into the groove in the underside of the mixer base.
- 2: Screw the flexible hoses into the mixer body, and fully hand tighten.
- 3: Pass the tail of flexible hoses through the hole on the basin from above, and place the mixer in position on the basin, to see if any alteration to the existing supply pipe work is necessary, make any necessary alterations to the pipe work.
- 4: Slide the flat washers and mounting nut up the flexible hoses, then screw the mounting nut all the way up making sure the tap is in the correct position.
- 5: Check that the mixer body is correctly positioned, then fully tighten the locking screw.
- 6: Connect the water supply pipe to the tail of flexible hoses with the hot water and cold water.

G1/2 Cleaning Cartridge

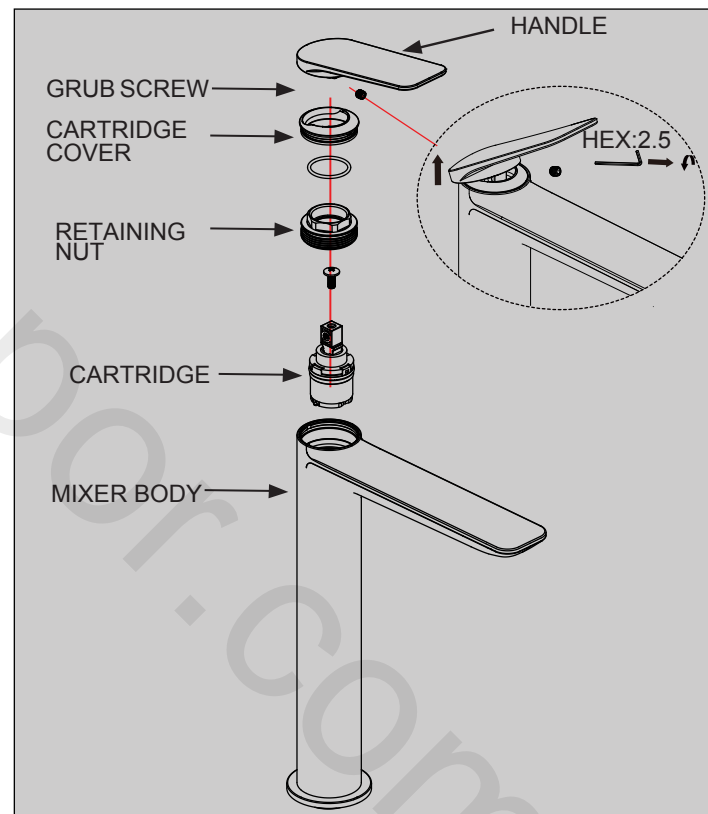

To remove the cartridge.

⚠ First shut off the water supply to the tap.

- 1: Loosen the grub screw in handle, but do not remove it.
- 2: Take off the handle, unscrew the cartridge cover.
- 3: Use a correct size spanner to unscrew the retaining nut.
- 4: Pull the cartridge and wash it with clean running water.
- 5: Dry and lightly grease the seals (only use silicone grease)
- 6: Replace them in turn.