

INSTALLATION INSTRUCTIONS

**Hoxton Floor Standing Mono Bath Shower
Mixer Chrome / Matt Black / Brushed Brass**

HOX.009CP/HOX.009MB/HOX.009BB

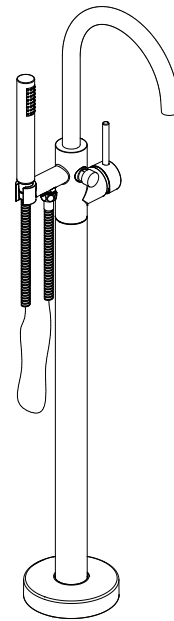

Important

- We recommend that this product is installed by a qualified professional contractor. Such as a plumber who is certified by NVQ (National Vocational Qualification) or SNVQ (Scottish National Vocational Qualification) Level 3.
- Please check this product immediately to ensure that it has not been damaged and is complete. Before installation, please make sure this product is the correct model and you have all the parts required for installation and using.
- All the taps should be supplied with hot and cold water at balanced pressure. If not, then the mixing function will not work correctly. It is necessary to fit non-return valves on both hot and cold feeds pipe. These are not supplied.
- Please flush the water system to ensure that no metal swarf, solder, and other impurities can enter the taps.
- Turn off water supply before commencing work, this should be done at the isolating valves of inlet feeds if fitted or main stopcock.
- Please read these instructions carefully and keep it for future reference.

Working pressure

The tap is suitable for high pressure installation. The tap is fitted with a ceramic disc cartridge which provides a smooth movement. The minimum work pressure is 1 bar. The maximum work pressure is 5 bar. If the mains pressure is over 5 bar, then a pressure reducing valve should be fitted.

Preparations and bylaw requirements

These taps are single flow so the hot and cold water mix in the body. Water Bylaws require that where hot water is supplied from tank and cold from mains, non return valves are fitted on both hot and cold pipes as close as possible to the tap. These are not supplied. Where combination boilers are fitted, it is only necessary to shut off the incoming mains and turn the boiler off and non return valves are not required.

Warning

Before installing the new mixer, it is essential that you thoroughly flush through the supply pipes in order to remove any remaining swarf, solder or other impurities. Failure to carry out this simple procedure could cause problems or damage to the working of the mixer. These hints are prepared in your guidance, you must exercise due care at all times. we do not accept responsibility for any problems that may occur through incorrect installation.

Maintenance

We do NOT recommend you use any household cleaners to clean the product. Because these cleaners change substance or formula too frequently. The product should be always cleaned only with soapy water and rinsed with clean water and dried with a soft cloth.

Dimension

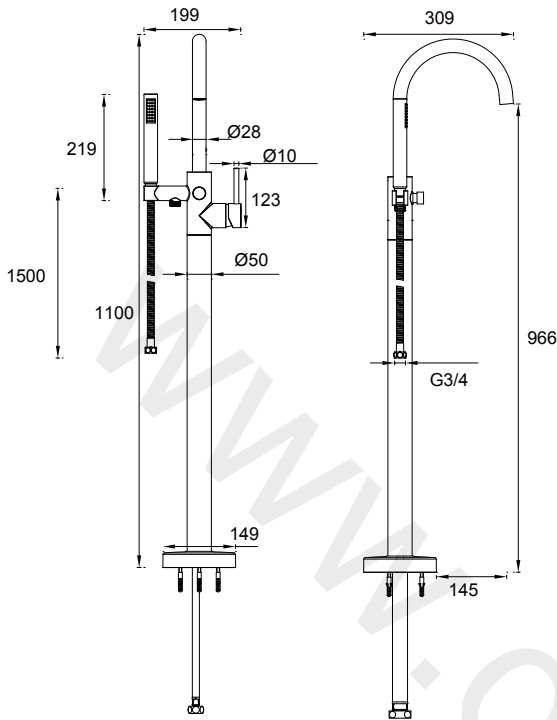

Cleaning Cartridge

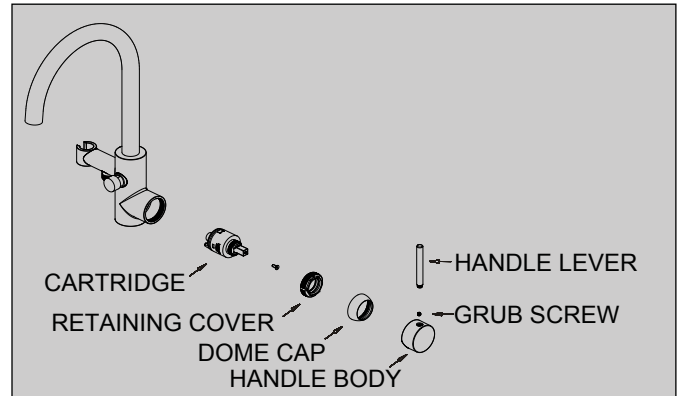

To remove the cartridge.

⚠ **First shut off the water supply to the tap.**

- 1: Unscrew the handle lever and then use a suitable hex key (not supplied) to loosen the grub screw, but do not remove it.
- 2: Pull off the handle body and unscrew the dome cap. Loosen the cartridge using an adjustable spanner (not supplied).
- 3: Take the cartridge out and wash it with clean running water.
- 4: Make sure any trapped debris has been removed.
- 5: Dry and lightly grease the seal (bottom of cartridge, only use silicone grease).
- 6: Refit the cartridge followed by the retaining cover, dome cap and handle.

Installation

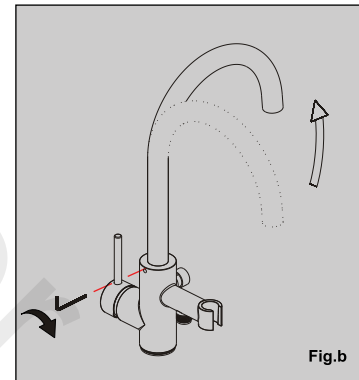
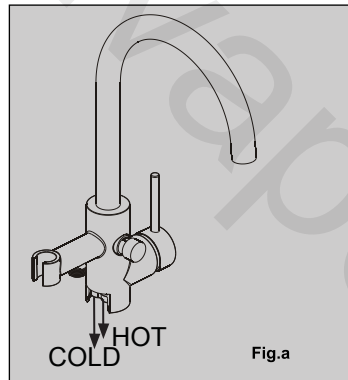
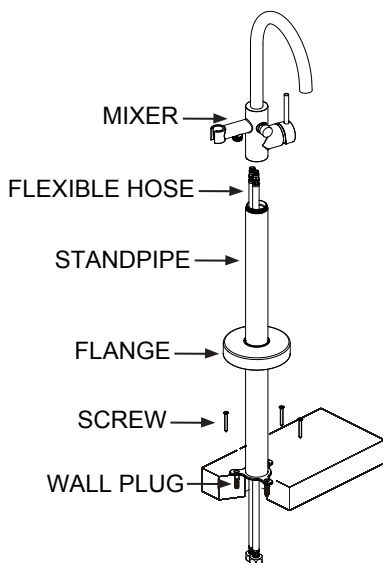

NOTE: The dimensions of the ground mounting holes need to be installed by the installer according to the product size and the actual installation requirements.

1. Place the flange over the standpipe and then place it to the base.
2. Put flexible hoses up through the standpipe and then attach the flexible hoses to the mixer, **Please note not to reverse the cold and hot supply. see <figure a> for reference.**
3. Attach the mixer to the standpipe.
4. Locate the assembly on the desired location with the flexible hoses through the prepared hole. Connect the flexible hoses to water supplies. Then hold the flange, secure the standpipe.

NOTE: If mounting into wooden floor, secure the standpipe using screws only (wall plugs are not needed). If mounting into solid floor, drill suitable sized holes for wall plugs first, then insert wall plugs in the floor and finally secure the standpipe using screws. Where required ensure correct plugs for your floor type are used.

5. Loosen the grub screw at the back of mixer body, place the spout of mixer toward front and in the middle and then use the hex key supplied to tighten it. See <figure b> for reference.
6. Insert a washer into each end of the shower hose and then screw it to the shower and mixer.
7. Push the diverter to operate the shower.

