

inta

Infra Red Wall Mounted Tap

IR270CP & IR271CP

Installation and Maintenance Instructions



inta

Intatec Ltd

Airfield Industrial Estate

Hixon

Staffordshire

ST18 0PF

In this procedure document we have endeavoured to make the information as accurate as possible.

We cannot accept any responsibility should it be found that in any respect the information is inaccurate or incomplete or becomes so as a result of further developments or otherwise.

Tel: **01889 272 180**

Fax: **01889 272 181**

email: **sales@intatec.co.uk**

web: **www.intatec.co.uk**

Introduction

This installation guide has been produced for the IR270CP & IR271CP infra red wall mounted taps. These instructions cover the installation, operation and maintenance. Please read the enclosed instructions before commencing the installation of this product, please note;

We recommend that the installation of any Inta product is carried out by an approved installer.

Products

Infra red tubular tap 170mm length with battery box	IR270CP
Infra red tubular tap 170mm length with electronic transformer	IR271CP
Infra red tubular tap 220mm length with battery box	IR278CP
Infra red tubular tap 220mm length with electronic transformer	IR279CP

Components

Item	Components
------	------------

- | | |
|----|-------------------------------|
| 1 | Battery holder or transformer |
| 2 | Spout with infra red sensor |
| 3 | M4 x 6 grub screw |
| 4 | Concealing plate |
| 5 | Flexible hose |
| 6 | Backnut |
| 7 | Solenoid valve |
| 8 | Filter gasket |
| 9 | Tail piece |
| 10 | Allen key |

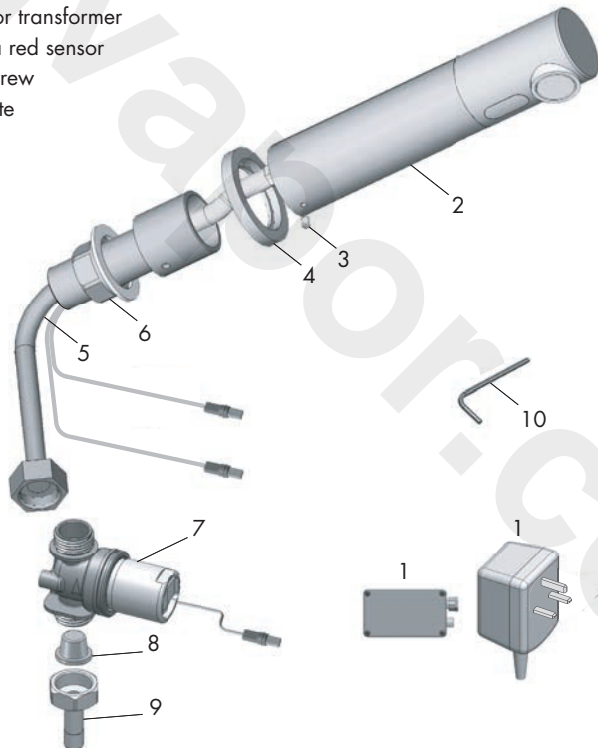

Check Contents

Before commencing remove all components from packaging and check each component with the contents list.

Ensure all parts are present, before discarding any packaging. If any parts are missing, do not attempt to install your Inta electronic tap until the missing parts have been obtained.

Technical Data

Power specification:

Power source -

9V

IR270CP: 6 x 1.5V AA batteries

IR271CP: 9V transformer

IR278CP: 6 x 1.5V AA batteries

IR279CP: 9V transformer

Operating water pressure:

0.5 to 8.0 bar (7 to 116 psi)

With water pressure in excess of 8 bar use with a pressure reducing valve.

Minimum sensor range:

80mm

Maximum sensor range:

300mm

Security time:

90 seconds - can be reduced via remote control

Hot water temperature:

70°C maximum - To limit the outlet temperature to 41°C max. we recommend using the Intamix Thermostatic Mixing Valve code 40015CP.

Self opening after last water flow:

Every 24 hours

Pre-installation Information

Warning

To avoid reflection problems keep a distance of more than 300mm between the basin and spout.

This tap with the infra red sensor pointing down, is not intended for use with a sink or basin made from a reflective material such as stainless steel.

If the water outlet is directly below the spout sensor, an outlet with a non-reflective finish should be used (do not use stainless steel).

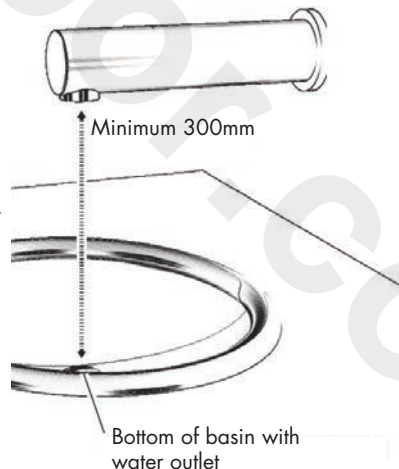

Pre-installation Information

Preparation for installation

Flush the water supply pipes thoroughly prior to installation. Do not allow debris, PTFE tape or any metal particles to enter the tap.

Do not expose to temperatures below 5°C, for example during winter. If the tap will be exposed to freezing conditions the tap and system should be drained.

Important: All plumbing is to be installed in accordance with applicable codes and regulations.

Installation

1. Your Inta tap must be installed in accordance with the Water Byelaws.
2. In order to prevent scalding, the tap should be connected to the hot water supply via a thermostatic mixing valve. The thermostatic mixing valve should have connections containing an isolating valve, should servicing be required in the future.
3. If a thermostatic mixing valve is not installed a service valve should be installed in the water supply pipe to the tap, should maintenance be required in the future.
4. Turn off the water supply using the service valve (not supplied).
5. Mark the position for the main hole and anti-rotational pin ensuring that the outlet for the spout will be over the basin.

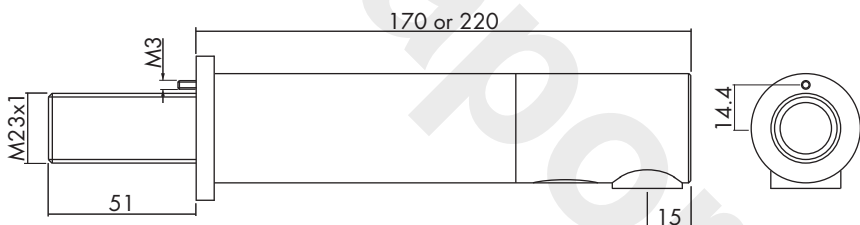

6. Drill a hole 23 to 24mm diameter for the spout of tap.
7. Drill a small hole 4mm diameter for the anti rotational pin.
8. Remove the backnut (6) from the threaded section, ensure the concealing plate (4) is located on the spout.
9. Insert the flexible hose (5) through the wall, the outlet from the spout must face the basin.
10. Insert the anti-rotation pin into the small hole.
11. Refit the backnut (6) onto the M23 thread and tighten to hold secure, do not over tighten.

Connecting the Water Supply

NOTE: The flow direction through the solenoid valve should follow the direction of the arrow on the valve body.

1. Connect the flexible hose (5) coming from the spout base to the solenoid valve (7).
2. Connect the mixed water supply to the inlet connection of the solenoid valve, using the filter gasket (8).

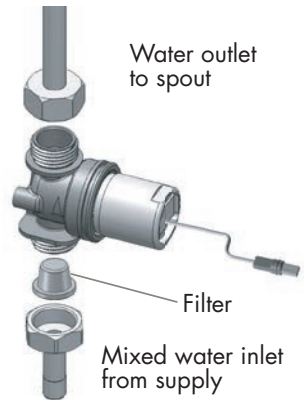

Connecting the power supply

1. Connect the cable from the power supply - battery or transformer to the spout.
2. Connect the cable from the spout to the solenoid valve.
3. Insert batteries into the battery box or connect the transformer to electricity supply.
4. Remove the sticker covering the infra red sensor.
5. After you have connected the power source wait 15 seconds to allow the system to set the ideal sensor range. As an indication that the self adjusting is occurring a red light in the sensor will flash continuously.
6. **The solenoid valve will open and close for 1 second and water flow as an indication that the ideal sensor range is set and the tap is ready to use.**

IMPORTANT:

This product must be installed by a suitably qualified and competent person carrying the relevant current IEE electrical qualification.



Ensure there are no objects in front of the sensor.



Remove the protective sticker from the sensor.



Wait approximately 15 seconds

Aerator

NOTE: The spout includes a special aerator that allows the water stream direction to be adjusted to prevent water splashing.

To change the angle of the water stream, simply move the adjustable tilting plate by pressing it firmly.

The aerator is securely fitted into the spout to prevent removal by hand.



Adjusting the Sensor Range

If the automatically adjusted sensor range is not satisfactory, please refer to the section "Settings Adjustment".

Prevention of Flooding

To prevent flooding the wash room following an act of vandalism or carelessness - an object left in front of the sensor or dirty sensor, the tap has a safety device that shuts off the water flow after approximately 90 seconds.

Once the object has been removed or the sensor cleaned, the tap will start working again.

The model with the transformer unit has an automatic shut off which turns off the water supply until the power supply is re-established.

Battery Replacement - IR270CP & IR278CP

When battery power is low and about to run out, the red indicator light will blink at a constant rate when the user's hands are within the sensor range.

The battery must be replaced within two weeks.

1. Open the battery box carefully, remove the old batteries and replace with 6 new 1.5V AA batteries. Close the battery box.
2. The sensor in the spout will go through its self adjusting procedure.
3. Move away from the sensor range, wait approximately 15 seconds to allow the system to set the ideal sensor range. As an indication that self adjusting is occurring a red light in the sensor will flash continuously.
4. **The solenoid valve will open and close for one second and water flow from the spout as an indication that the ideal sensor range was set and the tap is ready to use.**
5. Spent batteries should not be disposed of with normal house hold waste.

Recycle the batteries in an appropriate recycling bin or contact your local authority for information on waste disposal and recycling.



Aftercare

Filter cleaning

The tap is provided with a stainless steel filter, preventing debris from entering the solenoid valve and spout.

If the water flow from the spout has decreased this may be caused by the filter becoming clogged

The filter can be cleaned as follows:

CAUTION: turn off the water supply using the service valve before unscrewing the joint to remove the filter gasket for cleaning.

- Disconnect the inlet pipe to the solenoid valve and remove the filter.
- Wash the filter under running clean water until clean, if damaged it must be replaced.
- Re-assemble the filter and joint.
- Turn on the water supply and check the joint for signs of leakage.

General

- Inta taps have a high quality finish and should be treated with care.
- An occasional wipe with a mild washing-up liquid on a soft damp cloth followed by a thorough rinsing is all that is required.
- Do not use an abrasive or chemical household cleaner as this may cause damage.
- Cleaning the sensor - the darkened window which protects the sensor must always be clean in order for the tap to operate correctly; do not use abrasive material to avoid damaging the plastic surface.

Warranty

Limited Warranty

This product is covered by a limited warranty for one year from the date of purchase.

During this period Intatec Ltd undertakes, at its option, to repair or replace any faults caused by defective material or manufacturing faults that may arise (see Intatec Warranty).

This guarantee does not cover faults or damage caused by incorrect installation and/or maintenance, wear and tear, battery or water composition (eg hard water), this includes but is not limited to the following:

- Incorrect installation, inversion of supply pipes.
- Pressure or temperatures exceeding the recommended limits.
- Improper use, tampering, bad or lapsed maintenance.
- Foreign bodies, dirt or scale introduced by the water supply.

Trouble Shooting

Problem	Indication	Cause	Solution
No water flow from spout		Check if service valve is closed	Open service valve
	Sensor flashes continuously when user's hands are within sensor range	Exhausted battery	Replace battery
	Red light in sensor does not flash once when user's hands are within sensor range	Range is too short	Increase the range
		Range is too long	Decrease the range
		Battery is completely used up	Replace batteries
		Unit in "Security Mode"	
		Sensor is picking up reflections from the basin or other objects	Eliminate cause of reflection
	Red light in sensor flashes once when user's hands are within sensor range	Connectors between the spout and solenoid valve are disconnected	Reconnect the spout to the solenoid valve
		Debris or scale in solenoid valve	Unscrew solenoid, pull out the outer plunger and spring and clean them. Use scale remover if needed. When replacing the plunger, ensure the spring is vertical
		The central orifice in the diaphragm is plugged or torn	Clean the orifice or replace diaphragm
Water supply pressure is above 8 bar		Fit a pressure reducing valve	
Water flow from spout does not stop	Sensor flashes once when user's hands are within sensor range	Debris or scale in diaphragm	Clean the orifice or replace diaphragm
	Red light in sensor does not flash when user's hands are within sensor range	Sensor is dirty or covered	Clean sensor or remove object covering sensor
		Sensor is picking up reflections from the basin or other objects	Eliminate cause of reflection
Reduced water flow		Filter or aerator is clogged	Remove, clean and re-install

Settings Adjustment

The remote control is **NOT** supplied as standard with the tap and must be ordered separately, since for most applications the automatic sensor adjustment is sufficient.



If necessary, the sensor settings can be adjusted using the remote control as following:

- Shut off the water supply.
- In order to adjust the sensor with the remote control, hold the remote control straight in front of the sensor in a distance of about 6-8" (15-20cm).
- Choose the function you want to adjust by pressing once on one of the function buttons. After pressing once, a quick flashing of the red light at the front of the sensor will occur.
- At this stage, you can change the setting by pressing the (+) or the (-) buttons, every push will increase or decrease one level.
- After finishing the adjustment, turn the water supply back on.

Settings Adjustment

Detection Range: This tap is supplied with a Self Adjusting Sensor.

The ideal detection range for the specific location will be set automatically.

Only if necessary, use the remote control to adjust the sensor range as follows:



Press the **RANGE** button. Wait until the red light in the sensor starts to flash, then press + to increase the delay out time and - to reduce it, every push will increase or decrease one level.

NOTE: Once you have changed the detection range with the remote control, this distance will be remembered by the sensor, even if the power source is disconnected.

To get back to the self adjustment mode, use the ADJ button only.

Self Adjustment Mode:

Check that no objects are in front of the sensor. Press the **ADJ** button.



Once the red light of the sensor starts to flash, remove your hand holding the remote control away from the sensor area.

The ideal sensor range for the specific location will be set automatically.

Once the self adjustment has taken place the solenoid valve will be opened and closed for 1 second as an indication that the ideal sensor range was set and the tap is ready for use.

Security Time:

The security time, prevents continuous water flow due to reflections or vandalism.



By default, if the sensor is covered for more than 90 seconds the water flow will shut automatically.

To resume regular operation any obstruction must be removed.

Press the **SEC** button. Wait until the red light of the sensor starts to flash, then press + to increase the security time or - to reduce it.

Settings Adjustment

Delay In Time:



It is recommended to change the delay in time for flush valves for urinals or toilets only.

If required, the delay in time can also be modified for taps as follows:

Press the **IN** button. Wait until the red light of the sensor starts to flash, then press + to increase the delay in time and – to reduce it.

Delay Out Time:



This button allows modifying the water flow time after the user removes his hands from the tap.

A delay out time close to 0 will save more water. An increased delay out time will make the user experience more comfortable.

If required, the delay out time can be modified as follows:

Press the **OUT** button. Wait until the red light of the sensor starts to flash, then press + to increase the delay out time.

24 Hour Hygiene Flush:



If you have a compatible model with a 24 hours hygiene flush it is possible to enable or disable it .

To activate the hygiene flush, press the clock button. Wait until the red light of the sensor starts to flash, then press + to activate the hygiene flush or – to de-activate it.

Temporary Off Function:



This function is ideal to perform any kind of activity in front of the sensor without operating the tap (for example, cleaning).

The tap will remain shut for 1 minute when this button is pressed once.

To cancel this function and to return to normal operation press the On/OFF button again or wait 1 minute.

Reset Button:



This function restores all the factory settings except for the sensor range.

If required, press the **Reset** button and without releasing it, press the + button once.

inta

To activate your product warranty please visit
www.intatec.co.uk
and click on Product Registration

inta

Intatec Ltd

Airfield Industrial Estate
Hixon
Staffordshire
ST18 0PF

Tel: **01889 272 180**

Fax: **01889 272 181**

email: **sales@intatec.co.uk**

web: **www.intatec.co.uk**

E & O.E

© Intatec Ltd 2015

15-09-15