

BRISTAN

Installation Instructions and User Guide

Temperature Stabilised
Thermostatic Mixing Valve

Models Covered:

MT753CP, MT753CP-ISO

**Please keep this booklet for future
reference.**

Installer, when you have read these
instructions please ensure you leave
them with the user.

Contents

Welcome to your new Bristan Mixing Valve

All products manufactured and supplied by Bristan are safe provided they are installed, used correctly and receive regular maintenance in accordance with these instructions.

Isolation valves **must** be fitted to the inlet water supplies to ensure ease of future maintenance. This product **must** not be modified in any way as this will invalidate the guarantee.

Full access must be made available for future maintenance / servicing purposes. This product needs to be installed in accordance with, and meet the requirements of the Water Supply (Water Fittings) Regulations 1999 and Scottish Byelaws 2004.

These mixing valves have also been tested to the TMV2 and TMV3 schemes and comply to BS EN: 1287 and BS EN: 1111; so long as they are commissioned and serviced in line with TMV standards. Please read the TMV guide supplied with this valve for further information.



If in doubt, contact a registered plumber or your Local Water Authority or the Secretary of the Institute of Plumbing, address as follows;-

The Institute of Plumbing,
64 Station Lane,
Hornchurch,
Essex,
RM12 6NB, Tel: 01708 472791

Contents

• Specification	3
• Dimensions (mm)	3
• Installation	4-5
• General Cleaning	5
• Maintenance	6-7

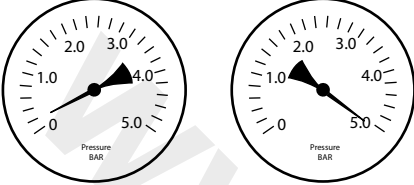
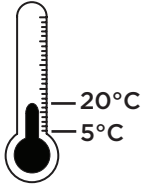
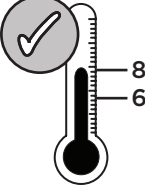
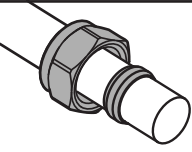
Specification

Specifications	Inlet Water Temperature		Inlet & Outlet Connection
<p>Working Pressures</p> <p>Min: 0.01 MPa (0.1 bar) Max: 0.5 MPa (5.0 bar)</p>  <p>Maximum Static Pressure: 1.0 MPa (10.0 bar)</p>	<p>Cold Water Supply</p>  <p>20°C 5°C</p>	<p>Hot Water Supply</p>  <p>80°C 65°C</p>	 <p>22mm Compression</p> <p>TMV2 Designation LP-B, HP-B, LP-W, HP-W, LP-T, HP-T, LP-S, HP-S</p> <p>TMV3 Designation HP-T44, HP-S, HP-W</p> <p>Outlet Temperature Pre-set to 43°C</p> 
<p>Min: 5°C Max: 20°C</p> <p>IMPORTANT</p>		<p>65°C Recommended</p> <p>The inlet hot water must be at least 10°C above the required blend temperature.</p>	

Maximum Pressure Differential: 20:1
Temperature Differential: +/-2°C from set temperature

The sensitive wax capsule will shut down the valve if the hot or cold water supply fails, provided that there is at least a 10°C difference between the mixed water temperature and the remaining supply.

Spare Parts

To replace any spare parts for your mixing valve, why not scan the QR Code or visit www.bristan.com and search for your product.



Dimensions (mm)

MT753CP

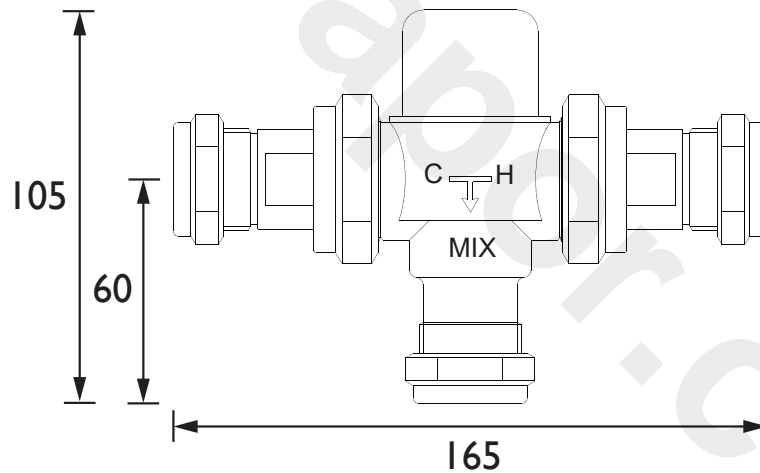

MT753CP-ISO

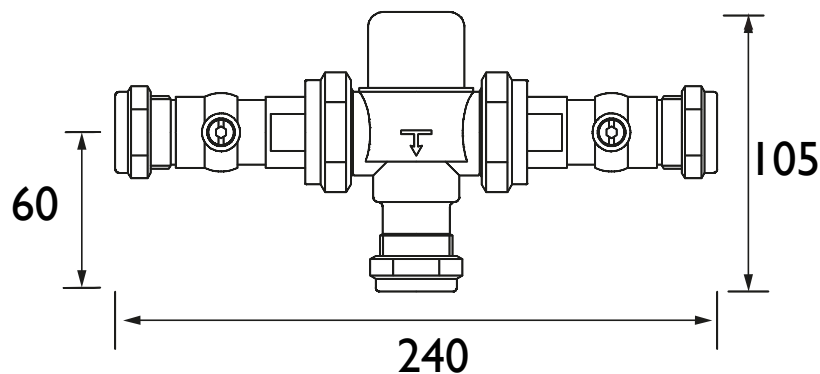

Installation

IMPORTANT: Please ensure both supply pipes are flushed before connecting the mixing valve to prevent plumbing/pipe debris from entering the mixing valve.

Also ensure that the mixing valve is situated in a place where the commissioning, testing and maintenance of to TMV standards can be undertaken.

Please read the TMV guide supplied with this product for more information.

1. Plumb the pipes to the desired location for the mixing valve, ensuring that they're secure in position.

If you have purchased MT753CP, we advise installing insulation valves as close as its practical to the mixing valve for ease of maintenance.

2. Connect the valve to the pipework, We recommend using a high tightening torque (45-50Nm) on all 22mm compression fittings to secure the valve.

Remember: Ensure the valve is fitted with the hot inlet on the left, cold on the right when viewed from the front.

3. Connect your chosen outlet to the mixing valve. Turn on the water supply and check all joints and connections for any leaks.
4. Please refer to the TMV guide in order to test and commission the mixing valve.

Components List

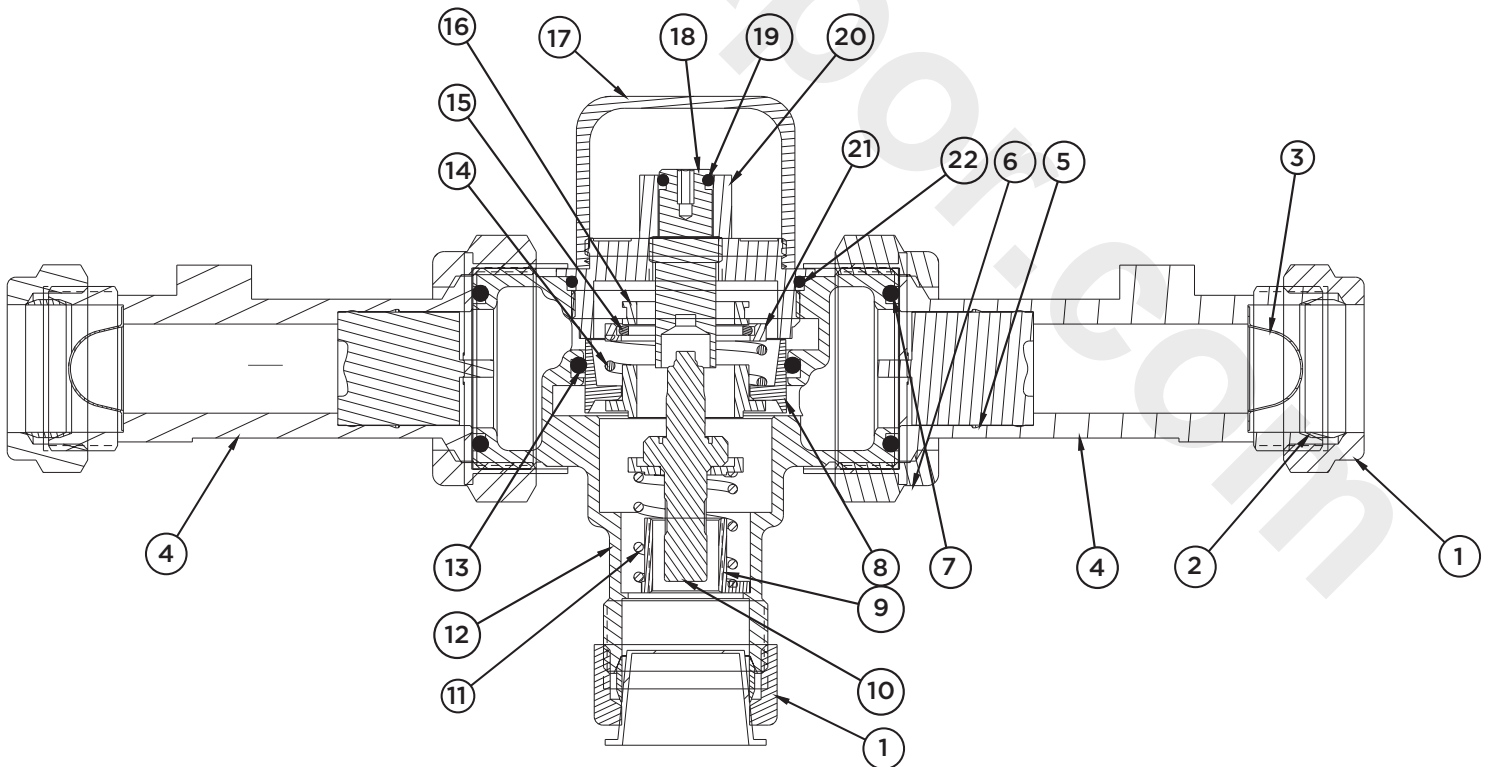

Installation

MT753 Components List					
Part No.	Description	Qty	Part No.	Description	Qty
1	22mm Compression Nut	3	12	Body	1
2	22mm Copper Olive	3	13	BS126 O-Ring 80 Shore	1
3	22mm Mesh Filter	2	14	Large Spring	1
4*	22mm Inlet Adaptor Assembly	2	15	Plain Ring	1
5	3/4" Check Valve	2	16	Thermostat Housing	1
6	28mm Cap Nut	2	17	Anti-tamper Cover	1
7	BS119 O-Ring	2	18	Adjusting Screw	1
8	Piston	1	19	BS010 O-Ring 90 Shore	1
9	Outlet Spacer	1	20	22mm Tee-Valve Head Assembly	1
10	Thermostat Element (0370)	1	21	Clamp Ring	1
11	Return Spring	1	22	BS029 O-Ring	1
* 22mm Isolating Adaptor Assembly for MT753CP-ISO					

General Cleaning

Bristan products are made from premium materials, with hand polishing and electroplated finishes.

Your shower kit should be regularly cleaned with warm water, a mild pH-neutral liquid soap, and polished with a soft cloth. Any residues from soap, toothpaste, shampoos and shower gels can cause blemishes if not rinsed off straight after use.

Household bleaches and cleaners contain harsh chemicals and may damage the surface finish. Avoid using abrasive cloths, scouring pads, scrub sponges, steel wool or anything similar.

Maintenance

Temperature Adjustment

This valve is pre-set to a maximum outlet temperature of 43°C.

It can be adjusted to have a maximum temperature between 30°C - 55°C

IMPORTANT: To comply with the TMV scheme, this valve cannot have a maximum outlet temperature of 44°C. If set higher, it will no longer comply with the TMV scheme.

Please see the TMV manual supplied with this valve for more details.

To adjust the temperature, follow the steps below:

1. Turn on the valve and set to the maximum temperature.
2. Remove the anti-tamper cover (17) from the body (12). Using a suitable hex key, insert through the head assembly (20) and locate into the groove of the adjusting screw (18).
3. Turn the adjusting screw (18) clockwise for a cooler temperature, anti-clockwise for a hotter temperature.
4. Wait for a few minutes after adjusting for the temperature to stabilise. Use a thermometer to measure the outlet temperature. Repeat step 3 until you have reached the desired result.
5. Replace the anti-tamper cover (17).

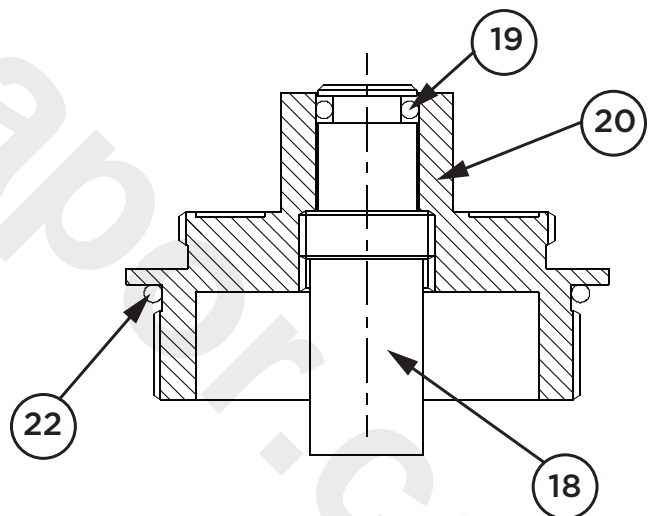
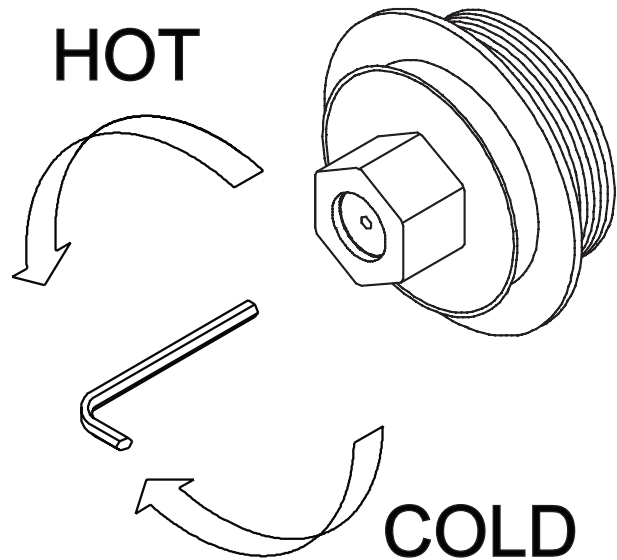

Head Assembly Parts		
Part No.	Description	Qty
18	Adjusting Screw	1
19	BS010 O-Ring 90 Shore	1
20	22mm Tee-Valve Head Assembly	1
22	BS029 O-Ring	1

Maintenance

Cartridge Cleaning

To clean the cartridge, follow the steps below:

1. Isolate the hot and cold water supplies. Remove the anti-tamper cover (17).

Note: If you have purchased the MT753CP-ISO, simply turn the screws in the isolation assemblies (4G) to isolate the water supplies.

2. Unscrew the head assembly (20) from the body (12) using a suitable spanner.

IMPORTANT: Note the position of the Adjusting Screw (18) before removing. It will need to be replaced in the same position in order to maintain the current maximum temperature.

3. Remove the thermostat (10), piston assembly (8), thermostat housing (16) and return spring (11).
4. Soak all components in a suitable solution until fully de-scaled. Check all seals and O-Rings for damage and replace if necessary.
5. Re-grease parts using a WRAS Approved grease and reverse the steps to re-assemble the valve.
6. Turn on the water supply and check all joints and connections for any leaks.
7. Follow the Temperature Adjustment process to check and re-calibrate the maximum temperature.

MT753CP-ISO Isolation Valve Assembly Parts		
Part No.	Description	Qty
4A	22mm Body	1
4B	Plated Brass Ball	1
4C	PTFE Seat	2
4D	22mm Copper Olive	1
4E	22mm Compression Nut	1
4F	Brass Nut	1
4G	Actuating Stem	1
4H	O-Ring	1
4I	Connecting Nut	1

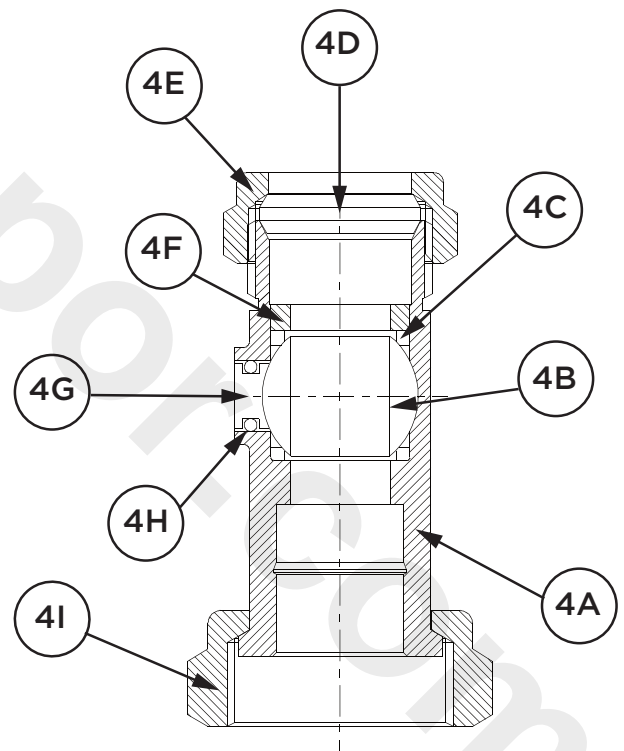

Issue: D

Part Number: 800486

BRISTAN

Bristan Group Ltd.

Birch Coppice Business Park

Dordon

Tamworth

Staffordshire

B78 1SG

Web: www.bristan.com

Email: enquire@bristan.com

A Masco Company

At Bristan, we want to make things as easy as possible for our customers. That's why we offer solid guarantees on all our products, effective from the date of purchase, to give you peace of mind.

To start your free guarantee simply scan the QR code and register your product. Alternatively visit www.bristan.com/register.

For any other queries, please call our Customer Service on 0330 026 6273 where our expert team of advisors will be able to offer you any help and advice.

For full guarantee terms and conditions visit www.bristan.com/guarantees.



We Know & We Care