

# inta

---

## Thermostatic Timed Flow Non-Concussive Basin Mounted Mixer Tap with Temperature Adjustment - NC250CP

### Installation and Maintenance Instructions

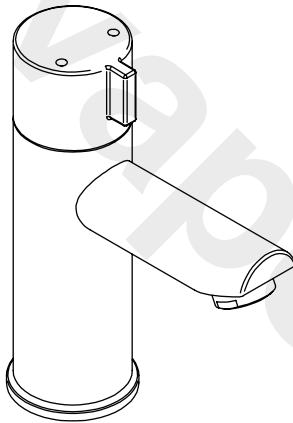

# inta

**Intatec Ltd**

Airfield Industrial Estate

Hixon

Staffordshire

ST18 0PF

In this procedure document we have endeavoured to make the information as accurate as possible.

We cannot accept any responsibility should it be found that in any respect the information is inaccurate or incomplete or becomes so as a result of further developments or otherwise.

Tel: **01889 272 180**

Fax: **01889 272 181**

email: **sales@intatec.co.uk**

web: **www.intatec.co.uk**

## Introduction

This installation guide has been produced for the NC250CP thermostatic non concussive basin tap. These instructions cover the installation, operation and maintenance. Please read the enclosed instructions before commencing the installation of this product, please note;

**We recommend that the installation of any product is carried out by an approved installer.**

The installation must be carried out strictly in accordance with the Water Supply (Water Fitting) Regulations 1999 and any local authority regulations.

If in doubt we recommend that you contact WRAS - Water Regulations Advisory Scheme on Tel: 0333 207 9030, your local water authority - details available on the WRAS website or the Chartered Institute of Plumbing and Heating Engineers on Tel: 01708 472 791.

All products MUST be re-commissioned to suit site conditions to ensure optimum performance levels of the product are obtained.

It is recommended, especially in hard water areas, that a water softener such as the ActivFlo or ActivFlo lite be fitted to reduce the risk of calcium deposits forming.

## Products

Thermostatic timed flow, non-concussive basin mounted mixer tap with temperature adjustment

NC250CP

## Check Content

Before commencing remove all components from packaging and check each component with the contents list.

Ensure all parts are present, before discarding any packaging. If any parts are missing, do not attempt to install your Inta thermostatic tap until the missing parts have been obtained.

## Components

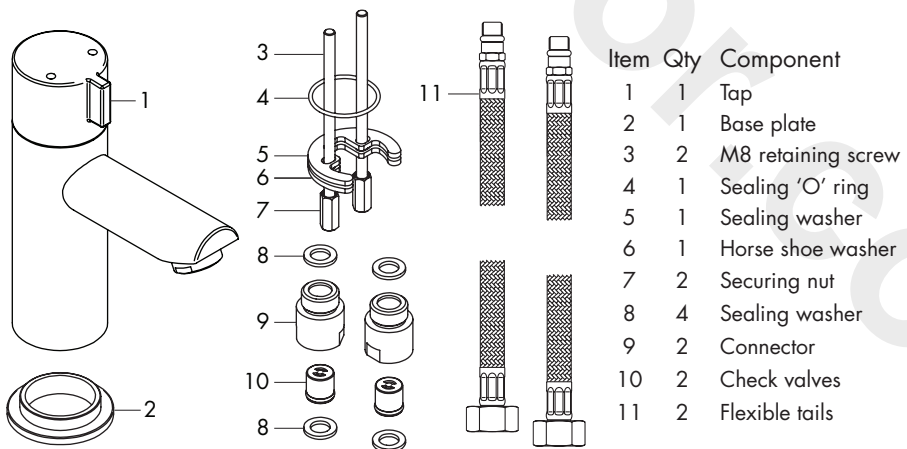

## General information

The NC250CP is a thermostatic non concussive basin tap with manual temperature adjustment is designed for wash basins with one tap hole.

Turning the control knob clockwise increases the mixed water temperature and anti-clockwise to reduce it.

Pressing the control knob turns on the mixed water flow.

## Technical Data

This Inta thermostatic mixer is suitable for installations on all types of plumbing systems, including gravity supplies, fully pumped, modulating combination boiler, unvented water heater and unbalanced supplies i.e. Cold Mains & Tank Fed Hot.

Minimum operating pressure:	1.0 bar
Maximum operating pressure:	5.0 bar
Maximum inlet temperature:	65°C
Minimum inlet temperature:	10°C
Temperature stability:	±2°C
Pre set factory temperature setting:	41°C
Min. temperature differential to ensure fail-safe between hot and cold supplies:	10°C
Max unbalanced pressure ratio without flow regulator:	5:1
Timed flow @ 1 bar:	15 ± 5 sec
Maximum basin thickness:	45mm

## Installation

Your Inta basin mixer must be installed in accordance with the Water Byelaws.

The NC250CP tap is designed to meet the requirements of TMV3 therefore a separate thermostatic mixing valve (TMV) is not required.

It is recommended that service valves are installed in the hot and cold water supply pipes in order to isolate the tap should servicing be required in the future.

All installations should be thoroughly flushed and cleaned to remove any debris that may affect the performance of the tap.

This mixer tap is designed for installing in one hole basins.

Fit the base plate (2) into the tap body (1).

Screw the retaining screws (3) into the threaded holes in the base of the tap body (1) taking care not to over tighten.

Connect the flexible tails (11) to the tap and tighten noting which copper tail is connected to the hot side of the tap.

The hot supply must be connected to the left hand side and the cold to the right hand side of the mixer when viewed from the front - see attached diagram.

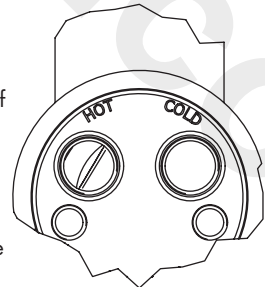

## Installation Continued

Ensure that the sealing 'O' ring (4) is seated correctly in the recess of the base plate prior to fitting the tap to the basin.

Once in place, add the sealing washer (5) and retaining plate (6) then secure in position, taking care not to over tighten the retaining nut (7).

Ensure that the check valves (10) are installed in the connectors (9) before screwing into the end of the copper tails.

Ensure the sealing washers (8) are used and all joints are water tight.

For optimum mixing performance where the hot and cold pressures are not equal, regulating valves should be installed directly upstream of the mixer so that the water supply pressures can be regulated and equalised.

## Operating

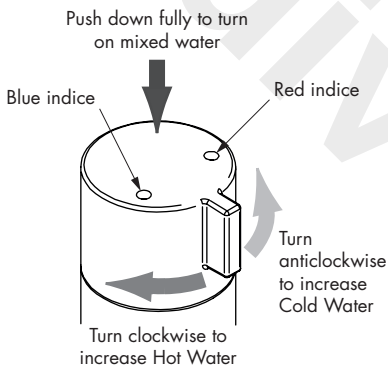

To turn on the mixer push down on the control knob until it contacts a stop and then release, mixed temperature water will flow for approximately 15 seconds.

If more water is required push again.

Rotating the control knob anticlockwise progressively closes the hot water port and opens the cold water port until it is fully open when only cold water flows when the mixer is turned on.

Rotating the control knob clockwise progressively closes the cold water port and opens the hot water port until it is fully open and water at the maximum temperature flows when the mixer is turned on.

## Aftercare

The aerator should be cleaned periodically to remove any build up of debris or deposits which may affect the performance of the tap.

Inta mixer taps have a high quality finish and should be treated with care.

An occasional wipe with a mild washing-up liquid on a soft damp cloth followed by a thorough rinsing is all that is required.

Do not use an abrasive or chemical household cleaner as this may cause damage.

## Servicing Instructions

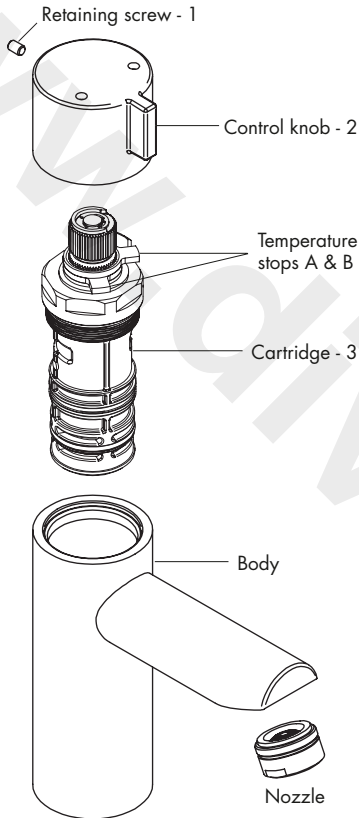

If the control knob cannot be depressed fully and does not return to its initial position within 15 seconds, or the temperature cannot be adjusted easily or water does not flow in a steady stream the mixer may require servicing.

Turn off the hot and cold supplies to the mixer.

Unscrew the retaining screw (1) and carefully remove the control knob (2).

Remove the 2 temperature stops A & B from the top of the cartridge (3).

The cartridge is a self container unit and should be removed as a single component.

Using a suitably sized spanner remove the cartridge (3) from the body.

Remove any debris that may have collected within the cartridge, ensure the stem rotates freely and can be depressed.

If limescale is visible soak the cartridge in a de-scaling solution until the stem rotates freely and can be depressed.

Do not attempt to dismantle any part of the cartridge, if necessary replace with a new cartridge.

Check the condition of 'O' rings and replace if necessary.

Using washing up liquid as a lubricant, to ease assembly and prevent damage to the 'O' rings, re-assemble the cartridge into the body and tighten.

Refit the two temperature stops A & B and follow the calibration procedure.

Re-assemble the other components in the reverse order and turn on the water supplies.

Check the mixer for correct operation.

## Calibration

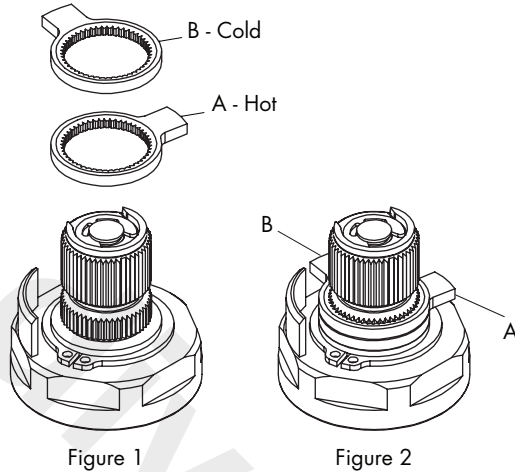

The thermostatic mixer tap has a factory set outlet temperature of 41°C via the security setting. This is based on a balanced supply pressure and a stable hot water inlet temperature of 65°C. However, the calibration point **MUST** be checked and re-set as necessary to suit site conditions. Care must be taken when re-calibrating the tap as **INCORRECT CALIBRATION CAN CAUSE INJURY**.

Unscrew the retaining screw (1) and carefully remove the control knob (2).

Remove both temperature stop rings (A & B) from the cartridge as shown in Fig 1.

Temporarily refit the control knob (2).

Using a digital thermometer increase or reduce the mixed water outlet temperature until 41°C is established and stabilised.

Remove the control knob (2) and refit the temperature stop rings (A) onto the splined section of the cartridge at the maximum temperature position.

Temporarily refit the control knob (2) and rotate clockwise until the water flow stops, refit temperature stop ring (B) as shown in Fig 2.

Refit the control knob in the reverse order.

Check calibration temperature.

**PLEASE NOTE THAT ONCE CALIBRATED, THE SECURITY SETTING WILL ONLY BE 41°C UNDER THE SUPPLY CONDITIONS USED FOR CALIBRATION.**

## Problem Solving

Problem	Solution
Mixed water temperature is not hot enough.	Ensure the hot water supply is at a constant temperature above 60°C Check for airlocks in the pipework.
The water goes cold during operation.	Insufficient stored hot water supply. Ensure that the boiler is still firing for combi boilers. Adjust the boiler control to a minimum setting of 65°C not necessarily the best flow rate.
Temperature is too hot or when set to hot water runs cold.	Check the commissioned maximum temperature of the valve. Check connections to the mixer are not reversed.
Flow of water through the valve is low.	Check the filters are clean and supply pressure is above 1 bar.
No flow of water.	Ensure the mixer has not fail-safed, and check that there is water flow to the mixer and the service valves are not closed.

**When this Mixer is used in a DO8 Application the following Instructions apply:**

## Introduction

This Inta Thermostatic Mixer Tap has been specifically designed and manufactured to meet the requirements of BS 7942: 2011 and NHS D08. The product has been independently tested and approved as a TYPE 3 valve under the TMV3 scheme.

## Technical Specification

Outlet Temperature Adjustment Range	30°C to 50°C
Temperature Stability	±2°C
Maximum Hot Inlet Temperature	85°C
Inlet Temperature Range	55°C to 65°C : Hot Supply 5°C to 20°C ; Cold Supply
DO8 Working Pressure Range	1.0 to 5 bar : High Pressure
Min Temp Differential (Mix to Hot) for Fail-Safe	10°C
Max Pressure Inlet Differential	5 : 1
Max Flow Rate @ 1 bar Differential	1500 l/h (25 l/m)

Operating Pressure Range	High Pressure
Maximum Static Pressure	10 bar
Flow Pressure, Hot and Cold	1 to 5 bar
Hot Supply Temperature	55°C to 65°C
Cold Water Temperature	5°C to 20°C

## Application

This thermostatic tap mixer has been independently tested by NSF and certified as meeting the requirements of the NHS D08 specification under the TMV3 Scheme as being suitable for use on the following;

Code	Application	Range
HP-W	Basin	High Pressure



## Installation

**IMPORTANT** – The following instructions must be read prior to the installation of any Inta thermostatic mixing tap.

The installer should also be aware of his responsibility and duty of care to ensure that all aspects of the installation comply with all current regulations and legislations.

It has been brought to our attention that flushing water systems using certain chemicals may affect the workings of the valve, which may adversely affect its performance.

We recommend that following system flushing with chemicals, mixers are checked for correct operation.

1. It is essential that, before installing a thermostatic mixer, the supply conditions of the system to which the valve is intended to be fitted are checked to confirm compliance with the parameters as quoted within the Technical Specification above and conditions on which the approval is granted i.e. verify supply temperatures, supply pressures, risk assessments etc
2. Consideration must be made for the possibility of multiple/simultaneous demands being made on the supply system whilst the thermostatic mixer is in use, all practical pre-cautions must be made to ensure that the tap is not affected. Failure to make provision within the pipe sizing etc will affect the performance of the tap.
3. The supply system to which the thermostatic mixing tap is to be installed into must be thoroughly flushed and cleaned to remove any debris, which may be accumulated during the installation. Failure to remove any debris will affect the performance and the manufacturer's warranty on the product.
4. Independent filters/check valves and isolation valves must be fitted in conjunction with the tap. In areas subject to hard water, provision must be made to treat the supplies prior to entering any product by fitting a water softener such as an ActivFlo or ActivFlo Lite.
5. The maximum flow rate of the valve will only be achieved when the supply conditions are achieved as quoted, with a flow condition under 1 bar differential pressure.
6. This Inta thermostatic mixer has been designed to be basin mounted. It is essential that access to the tap is not obstructed for future maintenance, that may be required to the tap or associated fittings.
7. The connection of the hot and cold supplies must be in accordance with the instructions shown on pages 2 and 3 i.e. hot water connected to the left hand side of the valve when the nozzle is facing you.
8. In a situation where one or both of the water supplies are excessive, it is recommended to fit a Pressure Reducing Valve, WRAS approved product, to reduce the pressure(s) to within those stated in the Technical Specification previously stated or a suitable flow regulator.
9. We recommend that Y pattern strainers and full bore isolation valves are installed in conjunction with this product as close as practically possible to the tap.
10. It is essential that this product should not be installed in situations where there is a possibility of the tap being deprived of water or where demands for water are greater than the actual stored supplies.

## Installation

11. To ensure that the performance levels of this Thermostatic Mixer are maintained (in the event of cold water failure) the temperature of the hot water supply at the point of entry to the valve must be a minimum of 10°C above the commissioned mixed water discharge temperature.
12. This Thermostatic Mixer must not be subject to any extreme temperature variations either during the installation or under normal operating condition.

## Commissioning

**IMPORTANT** – The following instructions must be read and understood prior to the commissioning of a Thermostatic Mixer. If under any circumstances there are aspects to the installation/system which do not comply with the specification laid down, the tap **MUST NOT** be put into operation until the system/installation complies with our specification.

1. Ensure that the system is thoroughly cleaned and free from any debris prior to the commissioning of the valve.
2. The commissioning of the temperature must be carried out using a suitably calibrated thermometer – preferably a digital thermometer.
3. In the absence of other temperatures being specified we recommend that the outlet temperatures quoted in table 1 are used, extracted from the “National Health Service – Health Guidance Note – Safe Hot Water and Surface Temperatures”.

**Table 1**

Application	Recommended Set Hot Water Temperature
Wash Hand Basin	41°C

4. Each tap must be commissioned taking into consideration any fluctuations, which may occur within the system due to simultaneous demands. It is advisable that any outlets which are connected to the same supply as the mixer tap are opened during setting of the mixed water temperature. It is advisable to ensure that the water temperatures are established before any attempt to commission.
5. Once the supply temperatures are stable and the normal operating conditions are established, the valve can be commissioned. We suggest that the following sequence is followed when commissioning the valve:
  - 5.1 Using the lever turn to the maximum hot setting of the tap, the mixed water temperature should be pre-set (see page 3).
  - 5.2 Measure and record the temperature of the hot and cold water connections to the tap.

## Commissioning

- 5.3 Isolate the cold water supply to the valve and monitor the mixed water temperature.
- 5.4 Measure and record the maximum mixed water temperature and the final temperature.  
The final temperature found during the test should not exceed the values quoted in table 2.

**Table 2**

Application	Maximum Hot Water Temperature
Wash Hand Basin	43°C

- 5.5 Record all the equipment used during the commissioning.
- 6. Ensure that the application, to which the tap will be used, is appropriate for the approved designation.
- 7. The above information must be recorded and updated on every occasion when any work is carried out on the tap.

## In-service Testing

To ensure that the thermostatic mixer maintains a high level of protection, we advise the following in service testing is followed (the same equipment used to commission the valve initially must be used in the following tasks).

- 1. After a period of between 6 and 8 weeks after commissioning carry out the following.
  - a) Record the temperature of the hot and cold water supplies.
  - b) Record the temperature of the mixed water at the largest draw off flow rate.
  - c) Record the temperature of the mixed water at the smallest draw off flow rate.
- 2. If the mixed water temperature has changed significantly from the previous test results (e.g. > 1 k), record the change and before re-setting the mixed water temperature check that:
  - a) All the strainers are clean
  - b) All the check valves are in good working order
  - c) The isolation valves are fully open.
- 3. If the mixed water temperature is acceptable, carry out the following:
  - a) Record the temperature of the hot and cold water supplies.
  - b) Record the temperature of the mixed water at the largest draw off flow rate.
  - c) Record the temperature of the mixed water at the smallest draw off flow rate.
  - d) Isolate the cold water supply to the mixing valve and monitor the mixed water temperature.
  - e) Record the maximum temperature achieved as a result and the final temperature (the final temperature should not exceed the values quoted in table 2)
  - f) Record the equipment used during these tests.

## In-service Testing

4. If during the test, paragraph 3, the mixed water temperature is greater than the values quoted in table 2 or the maximum temperature exceeds the corresponding values from previous test results by more than 2°C, the tap must be serviced.
5. After a period of between 12 and 15 weeks after commissioning, carry out the sequence of tests as described in 1, 2, 3 and 4 of this section.
6. Dependant upon the results obtained from the first two series of tests; there are a number of possible outcomes.
  - a) If no significant change in the mixed water temperatures (e.g. < 1°C) is recorded between commissioning and step 3e above or between commissioning and 5 of this section, the next in service testing should be carried out at a period of 24 to 28 weeks after initial commissioning.
  - b) If a small change (e.g. 1 - 2°C) in the mixed water temperature is recorded in only one of these periods, necessitating adjustment of the mixed water temperature, then the next in service test can be deferred to 24 to 28 weeks after commissioning.
  - c) If small change (e.g. 1 - 2°C) in the mixed water temperature is recorded in both of these periods, necessitating adjustment of the mixed water temperature, then the next in service test can be deferred to 18 to 21 weeks after commissioning.
  - d) If significant changes (e.g. >2°C) in the mixed water temperature are recorded in both of these periods necessitating service work, then the next in service test should be carried out at 18 - 21 weeks after commissioning.
7. The general principle to be observed after the first two or three in service tests is that the intervals of future test should be set to those which previous tests have shown can be achieved with no more than a small change in mixed water temperature.
8. In all areas periodic maintenance of the valve and associated fittings i.e. strainers, check valves will ensure optimum performance levels are maintained.
9. On the inlet strainers on both the hot and cold water supply inlet can be removed for cleaning.
10. The built in check valves can be accessed in a similar way to the filters to ensure freedom and correct seating.

## Notes

www.divapor.com

## Notes

www.divapor.com

## Notes

www.divapor.com

# inta

---

Please leave this Manual for the User

To activate your product warranty please visit  
**[www.intatec.co.uk](http://www.intatec.co.uk)**  
and click on Product Registration

# inta

**Intatec Ltd**

Airfield Industrial Estate  
Hixon  
Staffordshire  
ST18 0PF

Tel: **01889 272 180**

Fax: **01889 272 181**

email: **[sales@intatec.co.uk](mailto:sales@intatec.co.uk)**

web: **[www.intatec.co.uk](http://www.intatec.co.uk)**

E & O.E