

RADA MEYNELL 15/3 THERMOSTATIC MIXING VALVE

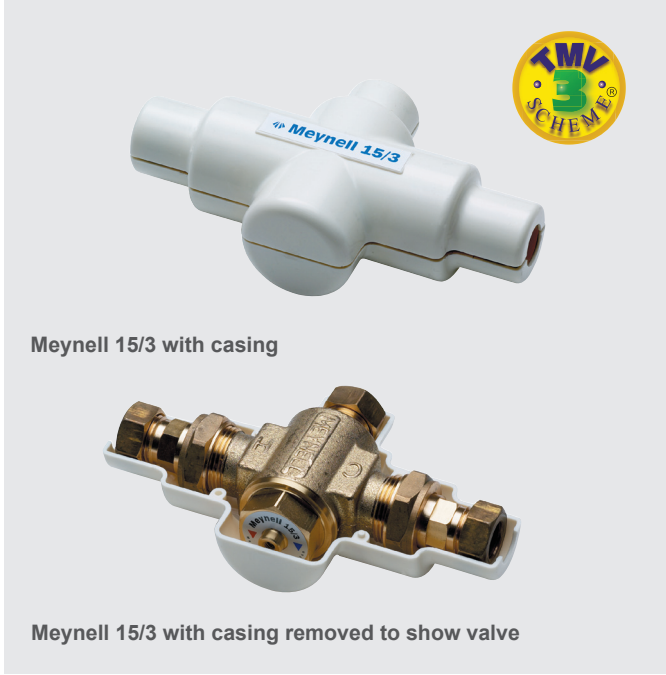

- Buildcert TMV3 Scheme Approved
- WRAS Approved
- Suitable for 'under-basin' or duct installation
- Safe thermostatic shutdown in less than 2 seconds
- Supplied in white easy clean casing
- Complete with integral check valves and strainers
- Tamper proof temperature adjustment



Specify as: Rada Meynell 15/3 (PESM0620J)
 1/2" point of use thermostatic mixing valve. Supplied complete with white plastic outer casing and integral check valves and strainers.

Dimensions (mm)

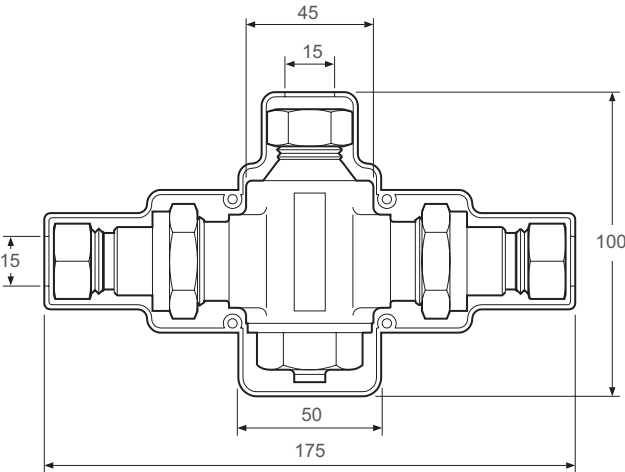

Flow Diagram

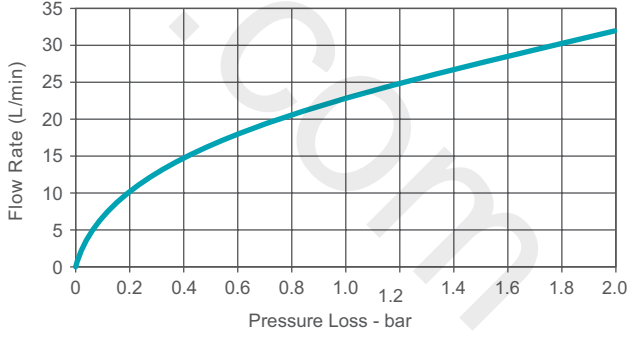

Kohler Mira Limited
 Cromwell Road
 Cheltenham
 Gloucestershire
 GL52 5EP

Specification Enquiries
 Tel: 0844 571 1777
 Fax: 0844 472 3076
 Email: rada_technical@mirashowers.com
 www.radacontrols.com



TECHNICAL SPECIFICATION

Installation and Maintenance

Please refer to the appropriate Product Manual.

Connections

Inlet and Outlets: 15 mm compression.

Approvals

Buildcert TMV3 Thermostatic Mixing Valve Scheme approved:

LP-W - Low Pressure Washbasin

LP-S - Low Pressure Shower

HP-W - High Pressure Washbasin

HP-S - High Pressure Shower

Certificate No: ETC/200/1202.

Complies with the technical requirements of BS7942 for the same designations.

Designed to comply with European Standards EN1111 and EN1287.

WRAS approved (Water Regulations Advisory Scheme).

Designed, manufactured and supported in accordance with accredited

BS EN ISO 9001:2008 Quality Management Systems and

BS EN ISO 14001:2004 Environmental Management Systems

Operation

The Meynell 15/3 is designed to be installed into the supply pipework and must be used with a separate outlet flow control such as a tap.

Materials

Body: DZR brass and housed in a white plastic casing.

Temperature Range

Factory pre-set maximum outlet temperature: 42°C.

Minimum temperature differential between hot inlet and preset outlet temperature: 10°C.

Optimum temperature control range: 35 °C - 45 °C.

Maximum hot water temperature: 85 °C (for safety reasons it is recommended that the hot water storage temperature is maintained at between 60°C to 65°C in ablutionary applications).

Pressures

Minimum operating pressure: 0.1 bar.

Maximum static pressure: 10 bar.

Maximum pressure loss ratio*: 10:1 (in favour of either supply).

Maximum hot water supply temperature: 85°C.

Maximum cold water supply temperature: 25°C.

Note! Both hot and cold pressure should be nominally equal.

** Pressure loss ratio is determined by subtracting the resistance to flow of the outlet pipework and outlet fittings (generally known as the 'back pressure', and measured at the outlet of the mixing valve) from the dynamic pressures of the hot and cold water at the inlets of the mixing valve. This is at its extreme when the mixing valve is being used at its lowest flow rate and when the maximum inequality occurs in the pressure of the hot and cold water supplies.*

Weight

Product	Gross Weight (Kgs)	Total Packaged Weight (Kgs)
Meynell 15/3	1.500	1.569