

RADA MEYNELL V8/3 B AND BL THERMOSTATIC MIXER



- Buildcert TMV3 Scheme Approved
- Buildcert TMV2 Scheme Approved
- WRAS Approved
- High flow rates at low pressures
- Reliable thermostatic performance
- Safe thermostatic shutdown in less than 2 seconds
- Suitable for use on all plumbing systems
- Built-in and long lever versions available
- Single sequential control for ease of use



Specify as: Meynell V8/3 B (PRSM0563P)

1/2" built-in single sequential thermostatic mixing valve. Supplied complete with integral strainers.

Specify as: Meynell V8/3 BL (PRSM0625P)

1/2" built-in single sequential thermostatic mixing valve with long lever for less abled use. Supplied complete with integral strainers.

Dimensions (mm)

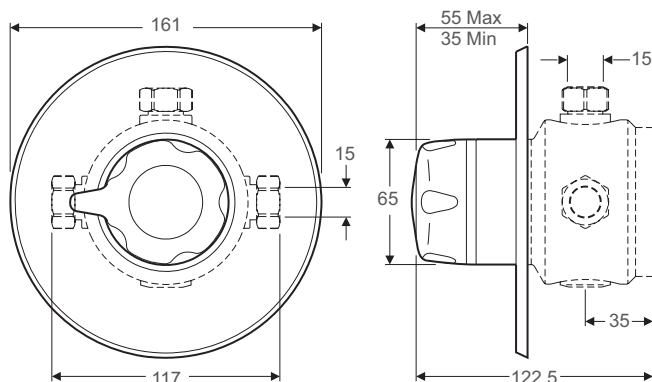

Flow Diagram

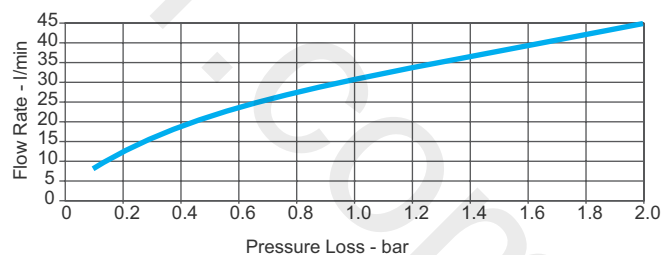

TECHNICAL SPECIFICATION

Installation and Maintenance

Please refer to the appropriate Product Manual.

Connections

Inlets: 15 mm compression.
 Reversible outlet connector: ½" BSP male or 15 mm compression

Standard connections are **hot-left, cold-right**, top outlet when facing the control.

Approvals

Buildcert TMV3 Thermostatic Mixing Valve Scheme approved:
 LP-S - Low Pressure Shower
 HP-S - High Pressure Shower
 Certificate No: ETC/22/0897.
 Complies with the technical requirements of BS7942 for the same designations.
 Buildcert TMV2 Thermostatic Mixing Valve Scheme approved:
 LP-S Low Pressure Shower
 HP-S High Pressure Shower
 Certificate No: BC197/0406
 Designed to comply with European Standards EN1111 and EN1287.
 WRAS approved (Water Regulations Advisory Scheme).
 Designed, manufactured and supported in accordance with accredited BS EN ISO 9001:2008 Quality Management Systems and BS EN ISO 14001:2004 Environmental Management Systems.

Operation

All V8/3 valves (excluding 'lockshield' model) are operated via a single sequential control which when rotated, initially opens the valve, then increases the temperature from cold through to a pre-settable maximum temperature stop.

Materials

Body: DZR brass chrome plated.

Temperature Range

Factory preset maximum outlet temperature: 42°C.
 Minimum temperature differential between hot inlet and preset outlet temperature: 10°C.
 Optimum temperature control range: 35°C - 45°C.

Maximum hot water temperature: 85°C (for safety reasons it is recommended that hot water storage temperature is maintained at between 60°C to 65°C in ablutionary applications).

The performance specification outlined below is achieved with outlet blend temperature set between 35°C - 45°C and supplies of 15°C cold and 65°C hot with nominally equal pressures:
 Outlet blend temperature is maintained within 2°C with a 10°C change

in hot or cold supply.

Shutdown of outlet flow to seepage within 3 seconds in the event of failure in either the hot or cold water supply, providing the blend temperature differs from the inlet supply temperature by at least 10°C. The valve will maintain control with a pressure loss ratio of up to 10:1.

Pressures

For optimum performance, maintained supply pressures should be nominally equal.
 Minimum maintained pressure 0.1 bar*
 Maximum static pressure: 10 bar
 Maximum pressure loss ratio**: 10:1 (in favour of either supply)
 * 1 metre head from underside of cold tank to outlet of shower fitting.
 ** Pressure loss ratio is determined by subtracting the resistance to flow of the outlet pipework and outlet fittings (generally known as the 'back pressure', and measured at the outlet of the mixing valve) from the dynamic pressures of the hot and cold water at the inlets of the mixing valve. This is at its extreme when the mixing valve is being used at its lowest flow rate and when the maximum inequality occurs in the pressure of the hot and cold water supplies.

Weight

Product	Gross Weight (Kgs)	Total Packaged Weight (Kgs)
Meynell V8/3 B	3.500	3.730
Meynell V8/3 BL	3.500	3.890

Kohler Mira Limited
 Cromwell Road, Cheltenham
 Gloucestershire, GL52 5EP

Specification Enquiries
 Tel: 0844 571 1777, Fax: 0844 472 3076
 Email: rada_technical@mirashowers.com
 www.radacontrols.com

Rada is a registered trademark of Kohler Mira Limited.
 The company reserves the right to alter product specification without notice.
 © January 2012 Kohler Mira Limited. All rights reserved.
 No part of this document, or any accompanying document, may be reproduced or transmitted in any form or by any means, including photocopying or electronically, without the permission of Kohler Mira Limited.

A **KOHLER** COMPANY



FM 14648

