

ARMITAGE SHANKS Fairline Kitchen S7071 Sink Pillars with Metal Handwheels

<p>

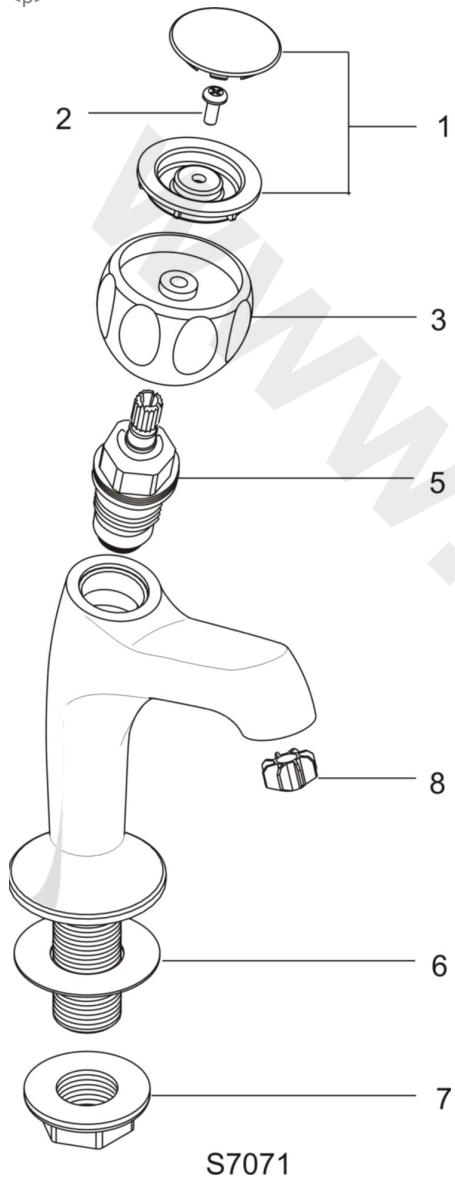

Ref.	Description
1a	Indice Ring Pack - Chrome
2	Retaining Screw Headworks M4 x 10.00
3	Metal Handwheel Pack - Chrome
5	MkIV universal headwork (2)
6	Shake proof washer
7	1/2in plastics backnut (2)
7a	E960112NU
8	Flow straightener - h/n sink pillars (2)

Part No.
S9684AA
S960066NU
S8046AA
S9613NU
E960459NU
EESC03AJ08NU
E960112NU
S9582NU

NB -- colour/finish options

Chrome = AA