

www.divapor.com

8 CLEANING & MAINTENANCE

The Contour II uses modern ceramic disc technology and should require little maintenance to the working parts.

The filters will keep the fitting free from waterborne debris; however, in some areas the aerator may require cleaning periodically to remove scale.

Remove the flow straightener or aerator element and descale separately if proprietary de-scalers are to be used to avoid damaging the chrome plating.

Clean chrome surfaces regularly using a soft damp cloth and mild detergent and wipe dry. Use of abrasives, solvents or acidic cleansers is not recommended.

Installation Instructions CONTOUR II PANEL MOUNTED SEQUENTIAL BASIN MIXERS

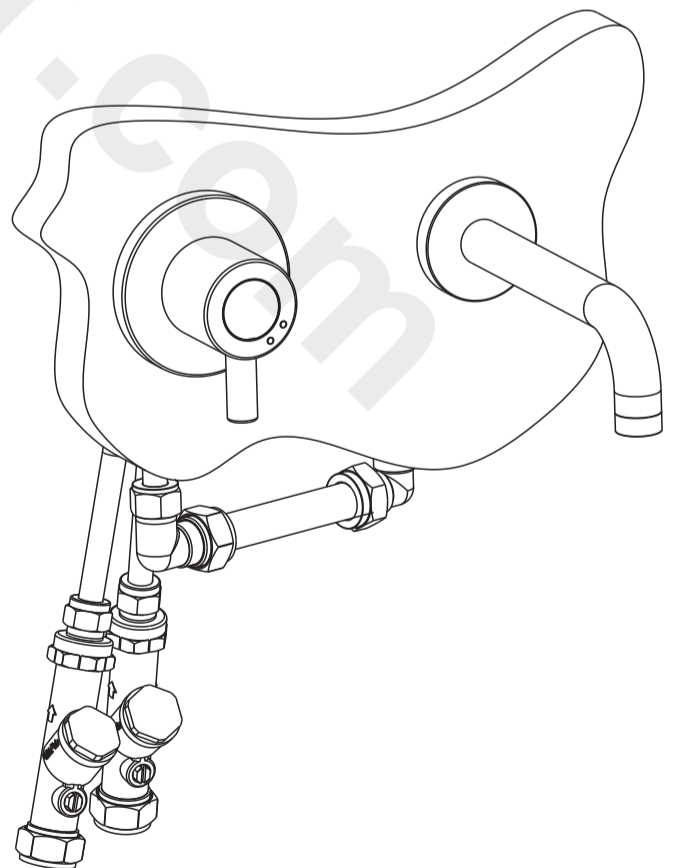

S7422 Contour II Sequential Panel Mounted Mixer with 150mm spout
S7423 Contour II Sequential Panel Mounted Mixer with 230mm spout

CUSTOMER CARE HELPLINE
0870 129 6085

CUSTOMER CARE FAX
01482 499611

E-MAIL
ukcustcare@idealstandard.com

Armitage Shanks pursues a policy of continuing improvement in design and performance of its products. The right is therefore reserved to vary specification without notice.

Armitage Shanks is a division of Ideal Standard (UK) Ltd

Armitage Shanks
The Bathroom Works, National Avenue
Kingston-upon-Hull, HU5 4HS England

4936 11/10

A866357

*Armitage
Shanks*

INSTALLER: After installation please pass this instruction booklet to user

2 SPECIFICATION

The Contour II is a single control panel mounted basin sequential mixer giving cold to hot in 140° of rotation. An alternative less restrictive flow straightener is provided for low pressure application.

Minimum head pressure:	0.3 bar (3 metres)
Maximum pressure:	5 bar (50 metres)
Differential pressures:	The mixer will tolerate differential pressures within the range given above provided the flow is controlled using the regulators supplied.
Typical flow:	~4 litre/minute
Recommended hot supply:	40°C
Design:	Single flow body (check valves are supplied so that the installation will conform to water regulations, e.g. where unbalanced supplies are used).

3 OPERATION

Turning the handle anti-clockwise initially opens the cold giving maximum cold flow. Further rotation progressively opens the hot whilst restricting the cold giving a mixed to fully hot flow.

4 INSTALLATION

The Contour II is panel mounted where the thickness of the panel is no greater than 26mm. The diameter of the hole for the mixer must not exceed 65mm or be less than 53mm and the hole for the nozzle must not exceed 35mm or be less than 22mm. Centre the holes horizontally at the required distance apart, typically between 70mm and 300mm.

Before connecting the mixer, flush out the supply pipes to remove any debris.

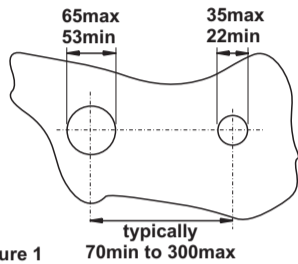

Figure 1

The inlet and outlet tails should be fitted after the mixer and the spout have been fixed to the panel. Tighten the back-nuts securely. Firmly screw in the tails. The hot inlet port has a red indicator and is on the right when viewed from the front with the connections from below.

The fitting is supplied with all necessary compression fittings, flow regulators and check valves. Only the 15mm copper tube has to be provided by the installer.

The flow regulators (4l/min) are pre-fitted in the downstream end of the strainer/isolating valve assembly and are held in place by circlips. Should these regulators ever require to be removed for cleaning it is important to ensure they are refitted the correct way round. (see Fig 2). The o-ring should be repositioned so that it engages in the rebate on the periphery of the flow regulator.

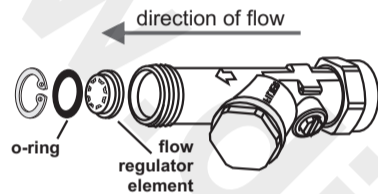

Figure 2

Connect to the supplies. Turn on the water, fully open the isolation valves and with the mixer closed check that all connections are watertight.

5 DIMENSIONS

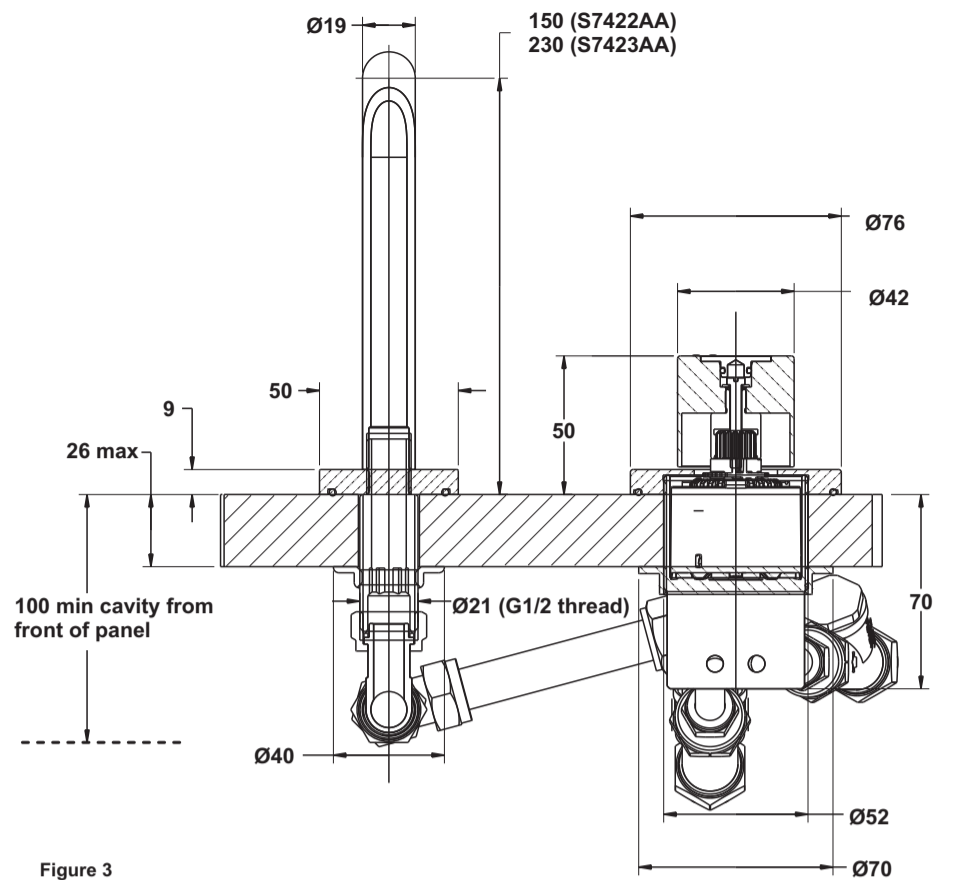

Figure 3

6 HOT LIMIT STOP ADJUSTMENT

By restricting handle rotation and limiting the amount of hot water allowed to mix with the cold, the **hot limit safety stop** (1) reduces the risk of accidental scalding.

To set the maximum hot water temperature of the fitting, all you need to do is adjust the setting on the **hot limit safety stop** (1).

Turn **cartridge stem** (2) to the **off** position (coldest setting)

Use a flat blade screwdriver to prise free the **hot limit safety stop** (1).

Pull forward and rotate counterclockwise one number to limit hot water temperature. Use **arrow** (3) on **cartridge** (4) and **numbers** (5) on **hot limit stop** (1) for indication.

Push the **hot limit stop** back into its new position and check hot temperature

Repeat if necessary.

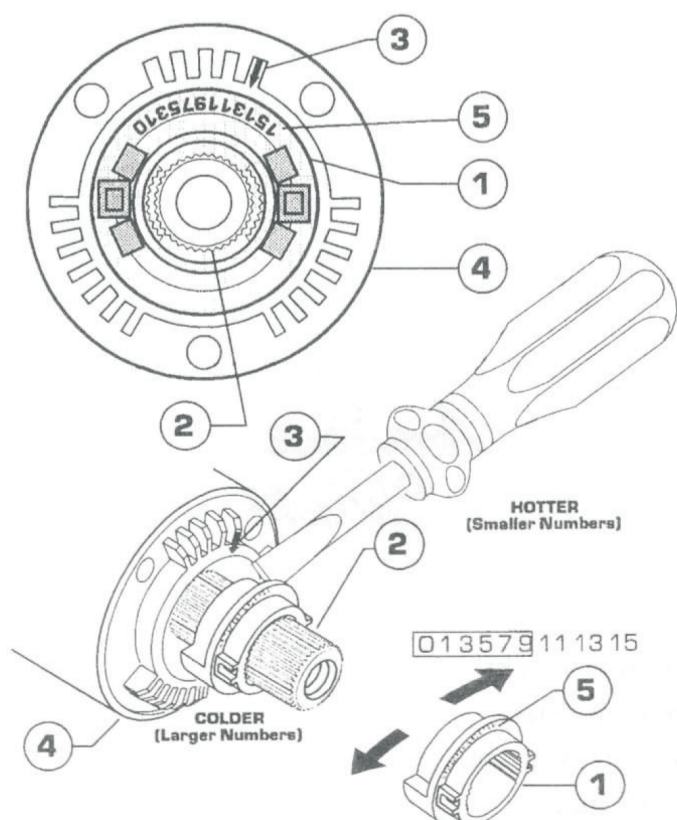

Figure 4

7 SPARE PARTS

1	S960049AA
2	S960028AA
2a	S960105NU
3	E907503AA
4	A954440NU
5	S960109NU
6	-
7a	S960048AA
7b	S960126AA
8	S960108NU
9	S960106NU
10	-
11	-
13	E960613NU
14	-
15	-
16	-

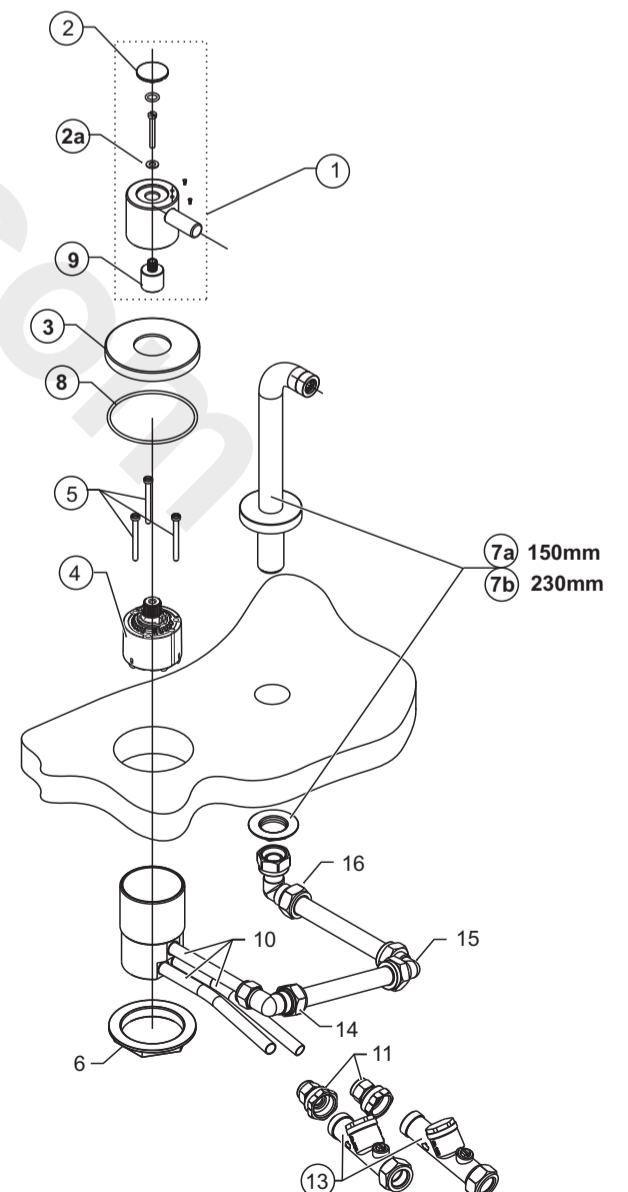

Figure 5