

TRITON

T70 GSI

electric shower

**REGISTER ONLINE
ENTER A PRIZE DRAW**

**WIN
£100**

LOVE2SHOP VOUCHERS

VISIT OUR WEBSITE TODAY

TRITONSHOWERS.CO.UK/REGISTER

*PRODUCT REGISTRATION IS ONLY AVAILABLE
TO UNITS PURCHASED & INSTALLED IN THE UK*



FOR YOUR SERVICE REFERENCE

NOTE DOWN THE PRODUCT CODE BELOW
(FROM THE FRONT OR TOP OF THE BOX)

ALTERNATIVELY REGISTER BY TEL: 024 7637 8321

IMPORTANT SAFETY ADVICE

The shower unit **MUST BE** switched off at the isolating switch when not in use. This is a safety procedure recommended for all electrical appliances.

The showerhead and hose supplied with this product are a safety critical part of your shower. Failure to use genuine Triton parts may cause injury and invalidate your guarantee.

INSTALLATION AND OPERATING INSTRUCTIONS

Please read this book thoroughly and familiarise yourself with all instructions before commencing installation and keep it for future reference.

The shower installation **MUST** be carried out by a suitably qualified person, **in the sequence of this instruction book.**



PLEASE READ THIS IMPORTANT SAFETY INFORMATION

Products manufactured by Triton are safe and without risk provided they are installed, used and maintained in good working order in accordance with our instructions and recommendations.

- ⚠ WARNING: DO NOT** operate shower if frozen, or suspected of being frozen. It must thaw out before using.
- ⚠ DO NOT** operate the unit if the showerhead or spray hose becomes damaged.
- ⚠ DO NOT** restrict flow out of shower by placing showerhead in direct contact with your body.
- ⚠ DO NOT** operate the shower if water ceases to flow during use or if water has entered inside the unit because of an incorrectly fitted cover.
- ⚠ WARNING: If restarting the shower immediately after stopping, be aware that a slug of hot water will be expelled for the first few seconds.**
- ⚠** The spray head must be descaled regularly.
- ⚠** Fit only shower heads recommended by the manufacturer and never fit any additional device to restrict the water outlet flow.
- ⚠** The outlet must not be connected to any tap or fitting other than those specified.
- ⚠** This appliance is intended to be permanently connected to the water mains and not connected by a hose set.
- ⚠** A suitable double pole isolation switch for supply disconnections must be incorporated in the fixed wiring circuit in accordance with current wiring rules. See Electrical Installation section for further details.

Mains water pressure only.

Minimum inlet pressure 100kPa (1 bar) 150kPa (1.5 bar) for 10.5kW

Maximum inlet pressure 1000kPa (10 bar)

This book contains all the necessary fitting and operating instructions for your electric shower.

Care taken during the installation will provide a long, trouble-free life from your shower.

⚠ WARNING ⚠

This appliance can be used by children aged from 3 years and above and persons with reduced physical, sensory or mental capabilities or lack of experience and knowledge if they have been given supervision or instruction concerning use of the appliance in a safe way and understand the hazards involved. Children may not play with the appliance. Cleaning and user maintenance shall not be made by children.



IMPORTANT - PLEASE READ THESE GENERAL GUIDANCE NOTES BEFORE PROCEEDING



1 GENERAL

- 1.1 Isolate the electrical and water supplies before removing the cover.
- 1.2 Read all of these instructions and retain them for later use.
- 1.3 **DO NOT** take risks with plumbing or electrical equipment.
- 1.4 Isolate electrical and water supplies before proceeding with the installation.
- 1.5 The unit must be mounted onto the finished wall surface (on top of the tiles). **DO NOT** tile up to or seal around **ANY PART** of the unit using silicone sealer after fixing to the wall. Special care must be taken **NOT TO BLOCK OR SEAL ANY PRD VENTS ON THE UNIT**.
- 1.6 Contact Customer Experience (*see back page*), if any of the following occur:
 - a) *If it is intended to operate the shower at pressures above the maximum or below the minimum stated.*
 - b) *If the unit shows a distinct change in performance.*
 - c) *If the shower is frozen.*
- 1.7 If it is intended to operate the shower in areas of hard water (above 200 ppm temporary hardness), a scale inhibitor may have to be fitted. For advice on the Scale Inhibitor, contact Customer Experience.
- 1.8 The showerhead must be cleaned regularly with descalent to remove scale and debris, otherwise restrictions to the flow on the outlet of the unit will result in higher temperatures and could also cause the (PRD) Pressure Relief Device in the unit to operate.
- 1.9 This product is not suitable for mounting into steam rooms or steam cubicles.

2 PLUMBING

- 2.1 The plumbing installation must comply with Water Regulations, Building Regulations or any particular regulations as specified by Local Water Company or Water Undertakers and should be in accordance with BS EN 806.
- 2.2 The supply pipe must be flushed to clear debris before connecting to the shower unit.

- 2.3 **DO NOT** solder pipes or fittings within 300mm of the shower unit, as heat can transfer along the pipework and damage components.
- 2.4 **DO NOT** fit any form of outlet flow control as the outlet acts as a vent for the heater can.
- 2.5 **DO NOT** use excessive force when making connections to the flexible hose or showerhead, finger tight is sufficient.
- 2.6 All plumbing connections must be completed before making the electrical connections.
- 2.7 This appliance **MUST NOT** be connected to the inlet supply by a hose-set.

3 ELECTRICAL

- 3.1 The installation must comply with BS 7671 'Requirements for electrical installations' (IEE wiring regulations), building regulations or any particular regulations as specified by the local Electrical Supply Company.
- 3.2 This appliance **MUST** be earthed.
- 3.3 In accordance with 'The Plugs and Sockets etc. (Safety) Regulations 1994', this appliance is intended to be permanently connected to the fixed wiring of the electrical mains system.
- 3.4 Make sure all electrical connections are tight to prevent overheating.
- 3.5 A 30mA residual current device (RCD) **MUST** be installed in all UK electric and pumped shower circuits. This may be part of the consumer unit or a separate unit.
- 3.6 Switch off immediately at isolating switch if water ceases to flow during use.
- 3.7 Other electrical equipment i.e. extractor fans, pumps must not be connected to the circuits within the unit.
- 3.8 Switch off at isolating switch when not in use. This is a safety procedure recommended with all electrical appliances.
- 3.9 As with all electrical appliances it is recommended to have the shower and installation checked at least every two years by a competent electrician to ensure there is no deterioration due to age and usage.

The shower installation must be carried out by a suitably qualified person in accordance with this instruction book.

SPECIFICATIONS

Electrical

| | |
|------------------------------|------------------------------|
| Nominal power rating at 240V | Nominal power rating at 230V |
| 8.5kW – (40A MCB rating) | 7.8kW – (40A MCB rating) |
| 9.5kW – (40A MCB rating) | 8.7kW – (40A MCB rating) |
| 10.5kW – (45A MCB rating) | 9.6kW – (45A MCB rating) |

Materials

Backplate, cover, controls, showerhead – ABS.
Sprayplate – Acetal.
Elements – Minerally insulated corrosion resistant metal sheathing.

Standards and Approvals

Splashproof rating IPX4.

Complies with the requirements of current British and European safety standards for household and similar electrical appliances.

Meets with Compliance with European Community Directives (CE).

IMPORTANT: When first installed the unit will be empty. It is essential the unit should contain water before the elements are switched on. It is vital that the commissioning procedure is followed. Failure to carry out this operation will result in damage to the unit and will invalidate the guarantee.

ADVICE TO USERS

The following points will help you understand how the shower operates:

- a.** The electric heating elements operate at a constant rate at your chosen power setting. It is the rate of the water passing through the heater can which determines the water temperature. The slower the flow, the hotter the water becomes; the faster the flow, the cooler the water.
- b.** During winter the mains water supply will be cooler than in the summer, so the flow rate will vary between seasons at any one temperature setting. At different times of the year you may have to adjust the position of the temperature control to maintain your desired temperature setting.
- c.** The stabiliser valve minimises variations in shower temperature during mains water pressure changes. If changes in shower temperature are experienced during normal use, it will most likely be caused by the water pressure falling near to or below the minimum level. The drop in pressure may be due to water being drawn off at other points in the house while the shower is in use. If pressure drops appreciably below the minimum, the heating elements will automatically cut out.

If ever the water becomes too hot and you cannot obtain cooler water, first check that the sprayplate in the showerhead has not become blocked.

DO NOT place items such as soap or shampoo bottles on top of the unit. Liquid could seep through the joint between the cover and backplate, and possibly damage the sealing rubber.

To check the product suitability for commercial and multiple installations, please contact Triton's specification advisory service before installation.

Telephone: 024 7637 2222

E mail: technical@tritonshowers.co.uk

CONTENTS

Page

INTRODUCTION

IMPORTANT SAFETY INFORMATION & GENERAL GUIDANCE NOTES *(please read)*

SPECIFICATIONS

GENERAL ADVICE TO USERS

Dimensions & entry points 6

Electrical requirements..... 7 - -8

Water requirements 9

User Operating Instructions 10 - 11

INSTALLING THE SHOWER..... 12 - 20

Siting of the shower..... 12

Fitting the shower to the wall 13 - 15

Plumbing connections 16

Electrical connections 17

Fitting The Cover - valve & knob positions..... 18 - 19

Commissioning procedure 20

Cleaning the filter - installers & service engineers only 21

Fault finding/Troubleshooting..... 22 - 23

Spare parts 24

SHOWER CONTROLS - quick user guide 25

UK Guarantee/Service Policy rear cover

| PRODUCT FICHE | | | |
|---|-------|-------|--------|
| Model | 8.5kW | 9.5kW | 10.5kW |
| Load Profile | XS | XS | XS |
| Energy Efficiency Class | A | A | A |
| Energy Efficiency (%) | 39 | 39 | 39 |
| Annual Electricity Consumption (kwh) | 482 | 483 | 480 |
| Sound Power Level (db) | 15 | 15 | 15 |

Fig.1

DIMENSIONS

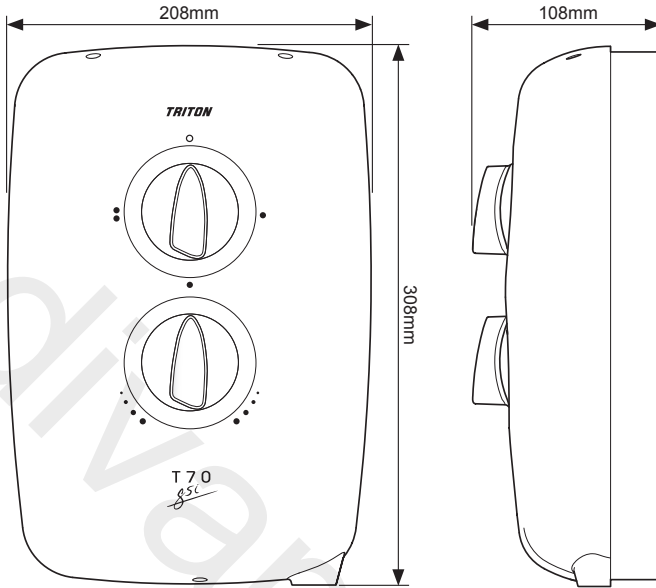
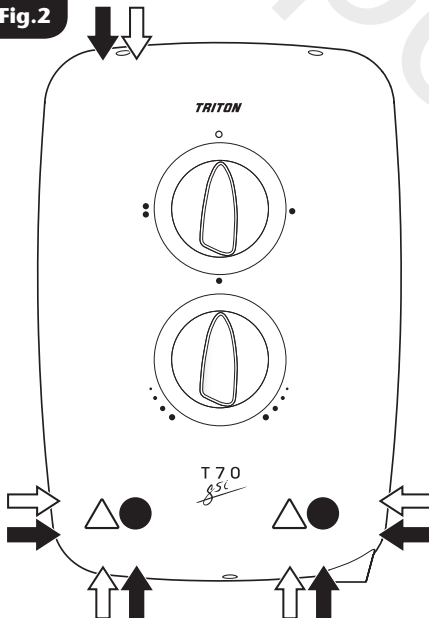

Fig.2

ENTRY POINTS



WATER ● = Back ➔ = Others

Left: Bottom, Back, Top & Side.

Right: Bottom, Back & Side.

CABLE △ = Back ➔ = Others

Left: Bottom, Back, Top & Side.

Right: Bottom, Back & Side.

Inlet connection: 15mm diameter.

Outlet connection: 1/2" BSP male thread.

ELECTRICAL REQUIREMENTS

⚠ WARNING! ⚠
THIS APPLIANCE MUST BE EARTHED

The installation, supply cable and circuit protection must conform with BS 7671 (IEE wiring regulations) and be sufficient for the amperage required.

The following notes are for guidance only:

- 1** The shower must only be connected to a 230-240V ac supply. If you are installing a shower with a kilowatt rating above 9kW, it is advisable to contact the local electricity supply company.
- 1.1** The electrical rating of the shower is shown on the rating label (**Fig.3**) within the unit.
- 2** Before making any sort of electrical connection within the installation make sure that no terminal is live. If in any doubt, switch off the whole installation at the mains supply and remove the correct fuse.
- 3** The shower must be connected to its own independent electrical circuit. **IT MUST NOT** be connected to a ring main, spur, socket outlet, lighting circuit or cooker circuit.
- 3.1** The electrical supply must be adequate for the loading of the unit and existing circuits.
- 4** Check your consumer unit (main fuse box) has a main switch rating of 80A or above and that it has a spare fuse way which will take the fuse or Miniature Circuit Breaker (MCB) necessary for the shower (**Fig.4**).
- 4.1** If your consumer unit has a rating below 80A or if there is no spare fuse way, then the installation will not be straightforward and may require a new consumer unit serving the house or just the shower.
- 4.2** You will need to contact the local electricity company. They will check the supply and carry out what is necessary.
- 5** For close circuit protection **DO NOT** use a rewirable fuse. Instead use a suitably rated Miniature Circuit Breaker (MCB) or cartridge fuse (**see Table A**).
- 5.1** A 30mA residual current device (RCD) **MUST** be installed in all UK electric and pumped shower circuits. This may be part of the consumer unit or a separate unit.

Fig.3 - Illustrative purposes only

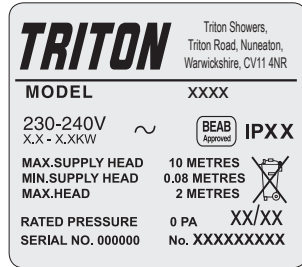

Fig.4 Schematic of installation circuit

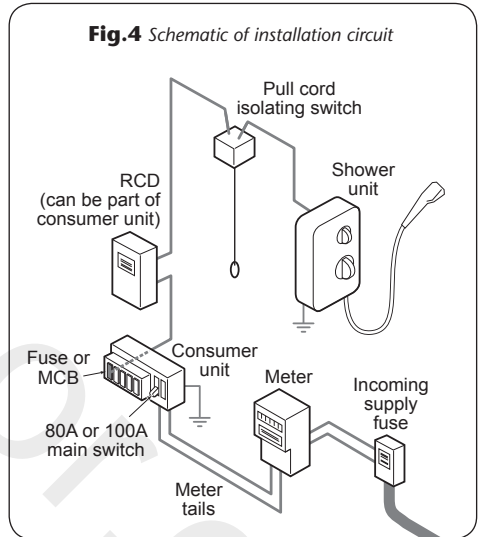

Table A

| unit rating | CIRCUIT PROTECTION | |
|-------------|--------------------|----------------|
| | MCB | cartridge fuse |
| 7.0kW | 30/32A | 30A |
| 7.5kW | 32A | 35A |
| 8.0kW | 40A | 35A |
| 8.5kW | 40A | 45A |
| 9.0kW | 40A | 45A |
| 9.5kW | 40/45A | 45A |
| 10.5kW | 45A | 45A |

- 6 A 45 amp double pole isolating switch with a minimum contact gap of 3mm in both poles must be incorporated in the circuit.
- 6.1 It must have a mechanical indicator showing when the switch is in the OFF position, and the wiring must be connected to the switch without the use of a plug or socket outlet.
- 6.2 The switch must be accessible and clearly identifiable, but out of reach of a person using a fixed bath or shower, except for the cord of a cord operated switch, and should be placed so that it is not possible to touch the switch body while standing in a bath or shower cubicle. It should be readily accessible to switch off after using the shower.
- 7 Where shower cubicles are located in any rooms other than bathrooms, all socket outlets in those rooms must be protected by a 30mA RCD.
- 8 The current carrying capacity of the cable must be at least that of the shower circuit protection (**see Table B**).
- 8.1 To obtain full advantage of the power provided by the shower, use the shortest cable route possible from the consumer unit to the shower.
- 8.2 It is also necessary to satisfy the disconnection time and thermal constraints which means that for any given combination of current demand, voltage drop and cable size, there is a maximum permissible circuit length.
- 9 The shower circuit should be separated from other circuits by at least twice the diameter of the cable or conduit.
- 9.1 The current rating will be reduced if the cabling is bunched with others, surrounded by thermal loft or wall insulation or placed in areas where the ambient temperature is above 30°C. Under these conditions, derating factors apply and it is necessary to select a larger cable size.
- 9.2 In the majority of installations (**see Table B**), the cable will unavoidably be placed in one or more of the above conditions. This being so, it is strongly recommended to use a minimum of 10mm cabling throughout the shower installation.

- 9.3 In any event, it is essential that individual site conditions are assessed by a competent electrician in order to determine the correct cable size and permissible circuit length.

Table B

| Twin and earth PVC insulated cable Current carrying capacity | | |
|---|----------------------------|---|
| Installed in an insulated wall | In conduit trunking | Clipped direct or buried in a non-insulated wall |
| 6mm ² 32A | 6mm ² 38A | 6mm ² 46A |
| 10mm ² 43A | 10mm ² 52A | 10mm ² 63A |
| 16mm ² 57A | 16mm ² 69A | 16mm ² 85A |

Note: Cable selection is dependent on derating factors

***The method below may be used by installers to determine the approximate size of the incoming cable.**

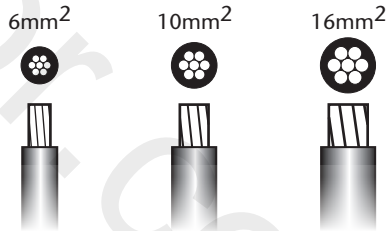

1. Measure the width of an individual strand, and half that measurement to find (r), e.g: $1.34\text{mm} \div 2 = (r) 0.67\text{mm}$
2. Multiply (r) x (r) x 3.14, e.g: $(r) 0.67 \times (r) 0.67 \times 3.14 = 1.41\text{mm}^2$
3. Multiply this by the number of wire strands (usually 7), e.g: $1.41\text{mm}^2 \times 7 = 9.87\text{mm}^2$.
4. The number obtained would suggest **10mm²** wiring.

***PLEASE NOTE:** If unsure, consult a qualified Electrician.

WATER REQUIREMENTS

The installation must be in accordance with Water Regulations/Bylaws.

| | |
|--|--|
| Supply Source..... | Mains pressure cold water |
| *Minimum running pressure and flow to the inlet of the shower for full performance | 100kPa (1.0 bar) at 8 litres per minute for 8.5Kw - 9.5Kw |
| *Minimum running pressure and flow to the inlet of the shower for full performance | 150kPa (1.5 bar) at 11 litres per minute for 10.5Kw |
| Maximum static pressure | 1000 kPa (10 bar) |
| Maximum inlet temperature | 28°C |
| Minimum inlet temperature | 2°C |

* **Note:** the shower will continue to operate on a reduced heat setting if the running pressure falls to **0.7 bar (1.2 bar for 10.5kW)**, there will be a noticeable reduction in flow and temperature from the showerhead.

If the stated flow rates are not available, it may not be possible to achieve optimum performance from the unit throughout the year.

During periods of high ambient temperatures it may be necessary to select the economy power setting to achieve your preferred shower temperature.

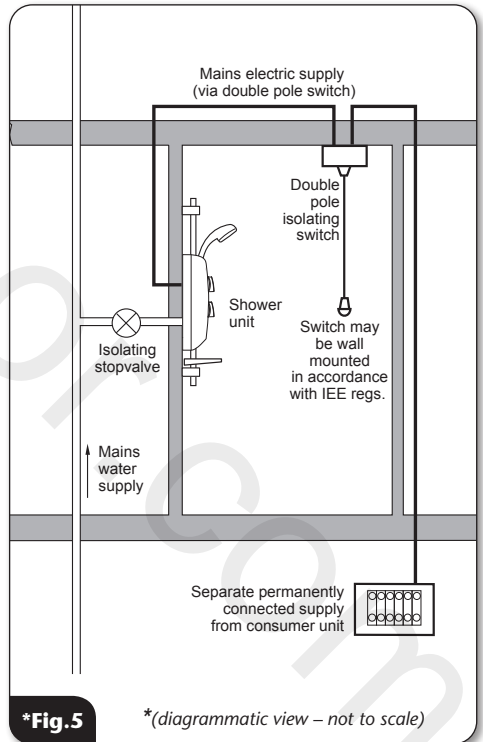
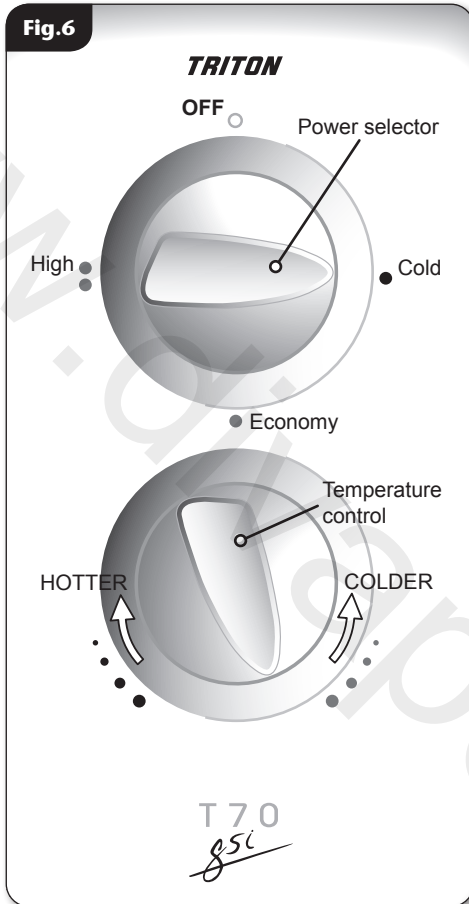

Fig.5 shows a typical system layout.
Do not use jointing compounds on any pipe fittings for the installation.

Fig.6



Note: In normal use, it is in order to leave the water supply permanently on to the shower unit, but as with most electrical appliances, **the unit must be switched off at the isolating switch when not in use.**

OPERATING THE SHOWER - (fig.6)
Make sure the commissioning procedure has been carried out.

To start the shower

- Turn the power selector to either **Cold**, **Economy** or **High** and the water will flow.

To stop the shower

- Turn the power selector to the **OFF** position.
- After stopping, the unit **MUST** be isolated via the 45amp-isolating switch.

NOTE: *If restarting immediately after stopping be aware that a slug of hot water will be expelled for the first few seconds.*

To use the power selector

The power selector has three 'ON' positions - **COLD**, **ECONOMY** and **HIGH**.

Cold setting - single blue circle.

- The cold setting does not provide any heat from the heater can to the incoming water.

Economy setting - single red circle.

- Economy uses only one of the elements within the heater can.

NOTE: *If the stated flow rate required for the unit cannot be met due to low water pressure, it will be necessary to operate the unit on this setting during the warmer months because of flow rate limitations entering the unit.*

High Setting - double red circles.

- High uses both of the elements within the heater can.

IMPORTANT: *It will take a few seconds for the temperature to stabilise once changes have been made.*

To adjust the shower temperature - Economy and High settings only

- The water temperature is altered by increasing or decreasing the flow rate of the water through the shower via the temperature control (**fig.6**).
- After obtaining your showering temperature, the knob can be left as the normal setting and should only need altering to compensate for seasonal changes in ambient water temperature.

NOTE: *The preferred knob position on ECONOMY will give a different temperature to the same position on HIGH.*

To decrease the shower temperature

- Turning the temperature control **anti-clockwise** will increase the flow of incoming water through the shower and make the showering water **colder**.

To increase the shower temperature

- Turning the temperature control **clockwise** will decrease the flow of incoming water through the shower and make the showering water **hotter**.

NOTE: *It is advisable that the showering temperature is satisfactory by testing with your hand before stepping under the showerhead. There will always be a time delay of a few seconds between selecting a flow rate and the water reaching the stable temperature for that flow rate.*

OPERATING FUNCTIONS

TP – Temperature Protection

During normal operation if the temperature exceeds the showering safety limit the power to the elements will be removed completely, although water will continue to flow. When the temperature has cooled sufficiently, power to the elements will be automatically restored to the settings at the time of interruption.

Abnormal Safety cut-out

The unit is fitted with a non-resettable thermal cut-out safety device. In the event of abnormal operation which could cause unsafe temperatures within the unit, the device will disconnect the heating elements. It will require a visit from a qualified engineer to determine the nature of the fault and replace the safety device once the unit has been repaired.

Two Stage Pressure Switch

This unit is fitted with a two stage pressure switch. In normal operation, 1 Bar running inlet pressure is required to enable the shower to operate at full power (1.5 Bar running inlet pressure required for 10.5kW unit). In the event a low pressure condition (down to 0.7 Bar), the shower will continue to operate at a reduced power setting (1.2 Bar required for 10.5kW unit). Below 0.7 bar pressure, all power to the elements will be removed. Power to the elements will be restored once the minimum appropriate inlet pressure is re-established.

IMPORTANT - CLEANING

It is recommended that all products are cleaned using warm, soapy water.

DO NOT use abrasive or aggressive chemical cleaning products as this may affect the product surface finish and invalidate your guarantee.

SITING OF THE SHOWER

- Refer to **fig.8** for the correct siting of the shower. Position the unit where it will **NOT** be in direct contact with water from the showerhead. Position the shower unit vertically.
- Allow enough room between the ceiling and the shower to access the cover top screws.

IMPORTANT: Water regulations (fig.8)

- It is required that the showerhead be '*constrained by a fixed or sliding attachment so that it can only discharge water at a point not less than 25mm above the spill-over level of the relevant bath, shower tray or other fixed appliance*'.
- If the riser kit is supplied with a 'soapdish hose retainer' or bespoke 'hose retainer', it will in most cases meet this requirement. If the showerhead can still be placed within a bath, basin or shower tray within the 25mm limit, then a double check valve, or similar, **MUST be fitted in the supply pipework to prevent back-flow**.

Pressure relief safety device

- A pressure relief device (PRD) is designed into the shower unit which complies with European standards. The PRD provides a level of appliance protection should an excessive build up of pressure occur within the shower.

DO NOT operate the shower with a damaged or kinked shower hose, or a blocked showerhead. This may cause the PRD to operate.

- When commissioning, the showerhead must be removed from the flexible hose. Failure to follow this procedure may cause the PRD to operate.
- Make sure the shower is positioned over a bath or shower tray. If the PRD operates, then water will eject from the bottom of the unit. Should this happen, turn off the electricity and water supplies to the shower at the isolating switch and stopvalve. Contact Customer Experience for advice on replacing the PRD.

WARNING!
The shower must not be positioned where it will be subjected to freezing conditions.

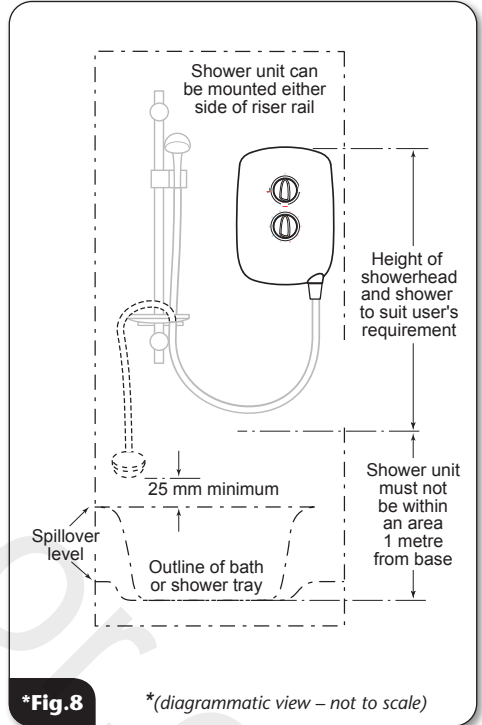

IMPORTANT: If installing onto a tiled wall, **ALWAYS** mount the unit on the surface of the tiles. **NEVER** tile up to the unit.

IMPORTANT: The unit must be mounted on a flat surface which covers the full width and length of the backplate. It is important that the wall surface is flat otherwise difficulty may be encountered when fitting the cover and subsequent operation of the unit may be impaired.

Fig.9

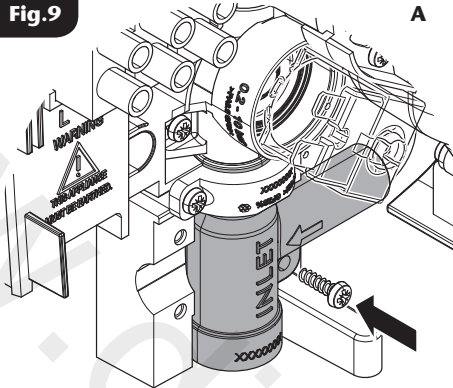

Secure inlet with screw.

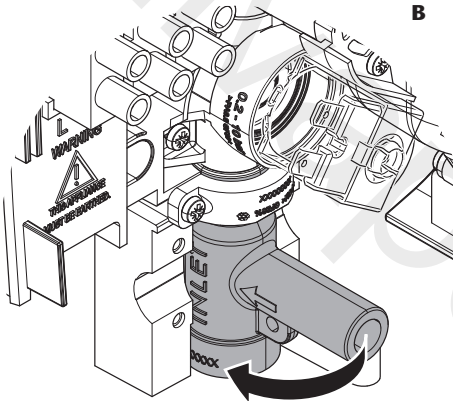

Turn inlet 180° for left entry.

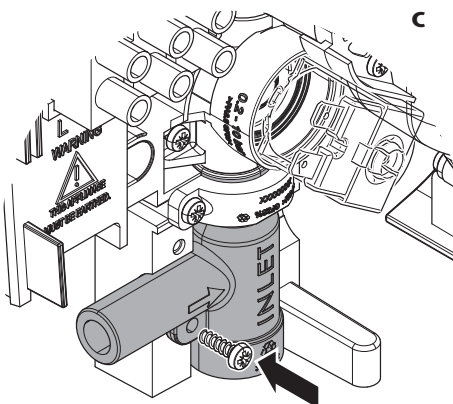

Secure inlet with screw.

FITTING THE SHOWER TO THE WALL

WARNING!

Check there are no hidden cables or pipes before drilling holes for wall plugs. Use great care when using power tools near water. The use of a residual current device (RCD) is recommended when using power tools.

NOTE: The control knobs are an integral part of the cover - **DO NOT** attempt to remove them.

- Lift the cover from the backplate.
- Entry positions for the mains water and electric cable can be found on **page 6**.

The water inlet (**fig.9**) has been designed to allow left or right fitting.

To make the inlet either left or right fitting:

- If right entry is required, secure with the screw included in the screw pack (**fig.9A**).
- For left inlet, turn the fitting 180° (**fig.9B**).
- Secure with the screw included in the screw pack (**fig.9C**).

NOTE: The Inlet is not fixed during production. Deviations from the designated entry points will invalidate product approvals and could invalidate product warranty.

Pipe access points

The shower cover has been designed with four 'cut out' bottom pipe access points and the backplate has been designed with one 'cut out' top rear - (fig.10) shows the top access backplate position and the bottom cover 'cut out' positions.

- Decide if top or bottom pipe entry is required.
- Once chosen, carefully remove the appropriate 'cut out' using a junior hacksaw and file.

PLEASE NOTE: NONE of the 'cut outs' are designed as 'snap out' entry points.

DO NOT remove using pliers. The use of pliers could damage the cover or backplate and may invalidate product specifications and warranty.

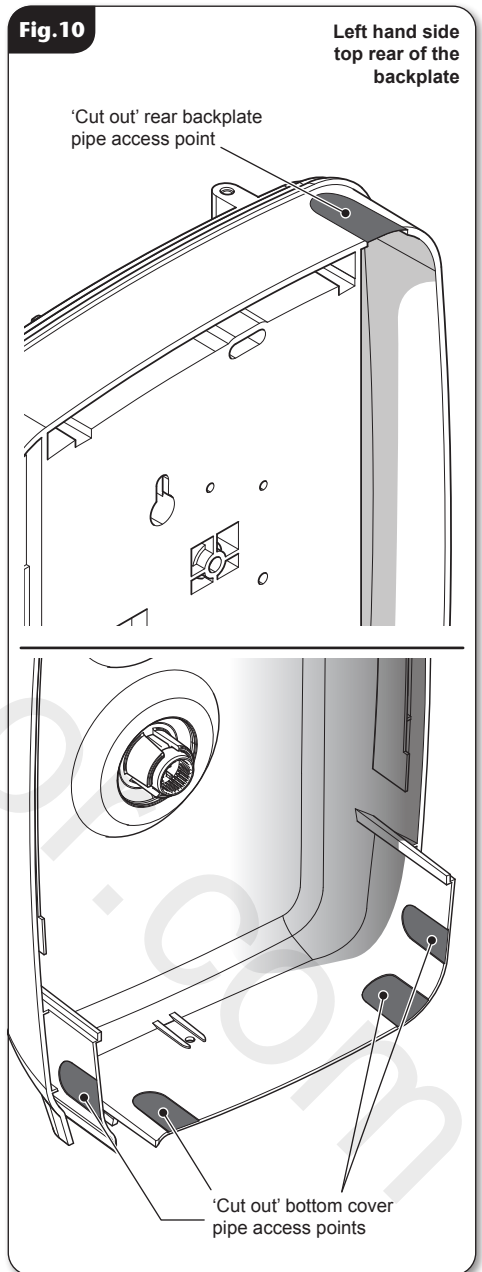
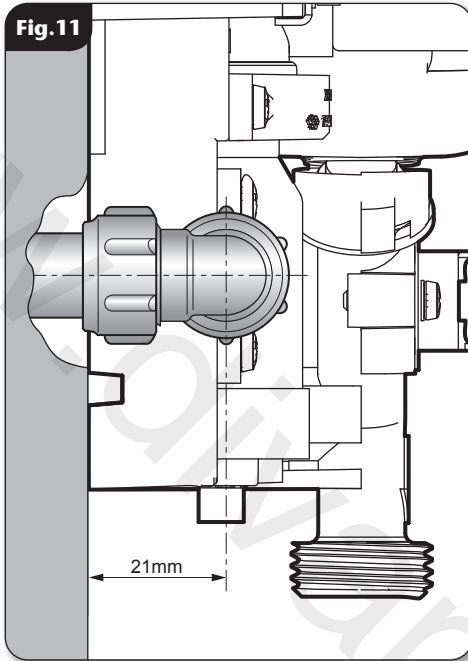

Fig.11



- If installing a feed pipe from the rear or bottom, the centre of the inlet valve to the wall surface is 21mm (**fig.11**).
- After choosing the site for the shower, use the backplate as a template to mark the fixing holes.
- The location of the fixing holes in the backplate are shown in (**fig.12**).
- Drill and plug the wall. An appropriate drill bit should be used. If the wall is brick, plasterboard or a soft building block, appropriate wall plugs and screws should be fitted.
- Screw the top fixing screw into position leaving the base of the screw head protruding 6mm out from the wall.
- Hook the backplate over the top screw and fit the bottom fixing screw into position. Do not fully tighten the screws at this stage, as the fixing holes are elongated to allow for out of square adjustment after the plumbing connections have been completed.

NOTE: If entry is from the rear, the nut of the compression fitting will be partially behind the surface of the wall (**fig.10**). This area **MUST** be left clear when plastering over the pipework in order to make the nut accessible for future adjustments.

IMPORTANT: A suitable sealant should always be used to seal around the incoming pipework to prevent water entering the wall.

Fig.12

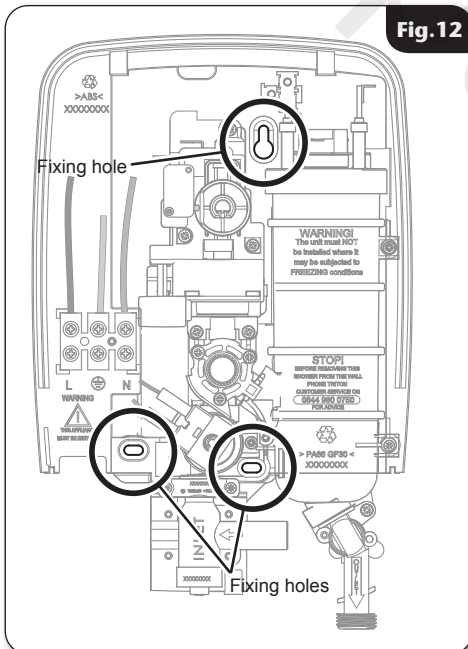

PLUMBING CONNECTIONS

Plumbing to be carried out before wiring

- **DO NOT** use jointing compounds on any pipe fittings for the installation.
- **DO NOT** solder fittings near the shower unit as heat can transfer along the pipework and damage components.
- Compression fittings **MUST** be used to connect to the inlet of the shower. (Push-on fittings must **NOT** be used as full engagement cannot be guaranteed).

NOTE: *An additional stopvalve (complying with Water Regulations) must be fitted in the mains water supply to the shower as an independent means of isolating the water supply should maintenance or servicing be necessary. If this isolator is fitted in a loft space, the loft must have a fixed access ladder and be boarded, with appropriate lighting from the access point to the isolator.*

IMPORTANT: *Before completing the connection of the water supply to the inlet of the shower, flush out the pipework to remove all swarf and system debris. This can be achieved by connecting a hose to the pipework and turning on the mains water supply long enough to clear the debris to waste.*

Procedure

- Turn off water supply either at the mains stopvalve or the isolating stopvalve.
- Connect the mains water supply to the inlet of the shower via 15mm copper, stainless steel or plastic pipe using a 15mm x 15mm compression fitting.
- **DO NOT** use excessive force when making these connections.
- Make sure the backplate is square on the wall and tighten the two retaining screws which hold it to the wall.
- Turn on the mains water supply and check for leaks in the pipework connection to the shower.

NOTE: *At this stage no water can flow through the unit.*

WARNING!

The outlet of the shower acts as a vent and must not be connected to anything other than the hose and showerhead supplied.

NOTE: *Before fully tightening the inlet connections, ensure that the pipework is aligned for the chosen entry position.*

Depending on the physical size of fittings used, it may be necessary to trim the inlet stem to accommodate the fitting.

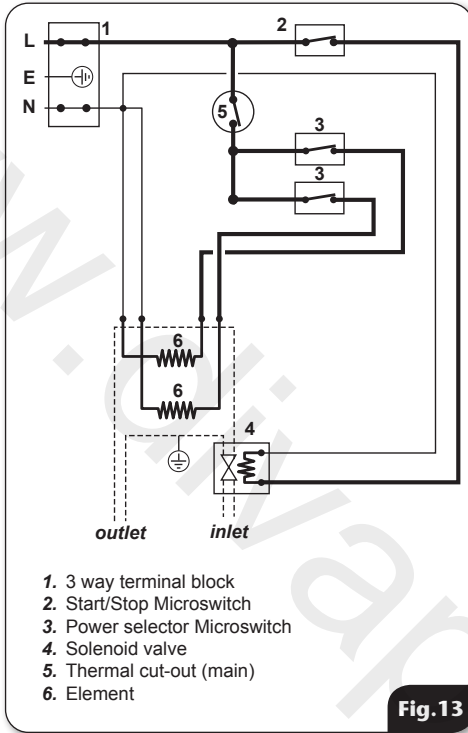

Fig. 13

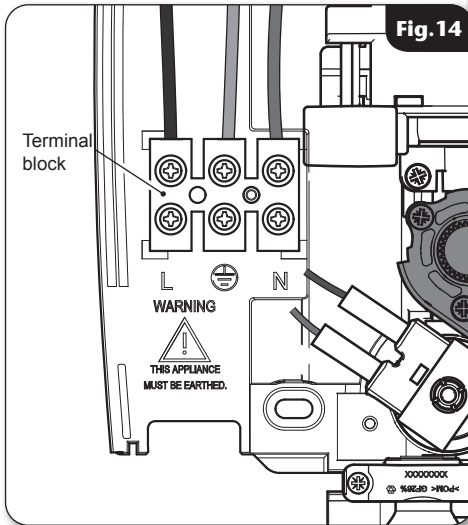



Fig. 14

ELECTRICAL CONNECTIONS

IMPORTANT: Switch off the electricity supply at the mains before proceeding.

- Fig. 13 shows a schematic wiring diagram.
- The cable entry points are listed on page 6.
- The cable can be surface clipped, hidden or routed via 20mm conduit.

NOTE: Conduit entry can only be from rear. Route the cable into the shower unit and connect to the terminal block (fig. 14) as follows:

- Earth cable to terminal marked 
- Neutral cable to terminal marked **N**
- Live cable to terminal marked **L**

IMPORTANT: Fully tighten the terminal block screws and make sure that no cable insulation is trapped under the screws. Loose connections can result in cable overheating.

NOTE: The supply cable earth conductor must be sleeved. The outer sheath of the supply cable must be stripped back to the minimum.

- The supply cable **MUST** be secured either by routing through conduit, in trunking, or by embedding in the wall, in accordance with IEE regulations.
- The use of connections within the unit or other points in the shower circuit to supply power to other equipment i.e. extractor fans, pumps, etc., will invalidate the guarantee.
- **DO NOT** switch on the electricity supply until the cover has been fitted.

NOTE: The elements on UK models are to 240V specification and will give a lower kW rating if the voltage supply is below 240V.

FITTING THE COVER

Figs 15, 16, 17 and 18 show the correct control knob position when replacing the cover.

- 1.** With the cover off the shower turn the POWER selector spindle clockwise until the flat section is on the bottom (**fig.15**).

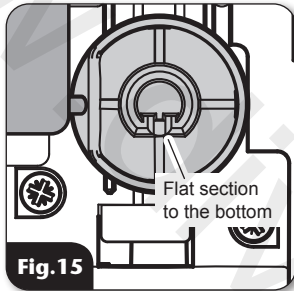
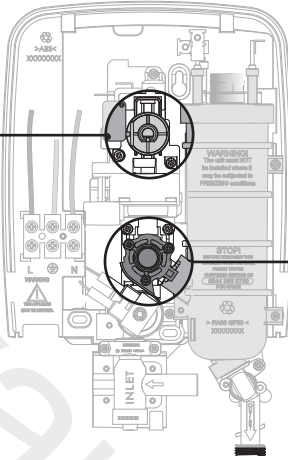

Fig.15



- 2.** With the cover off the shower turn the stabiliser valve spindle fully clockwise until resistance is felt (**fig.16**).

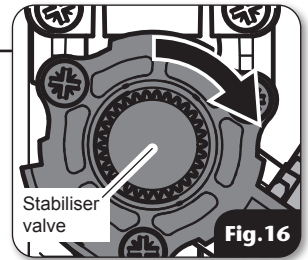
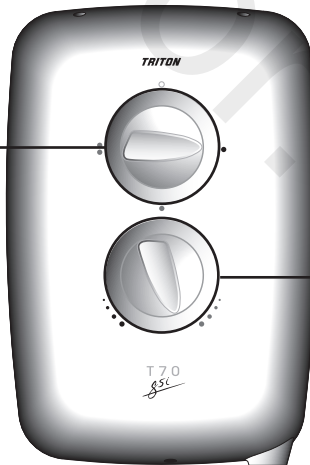

Fig.16

- 3.** With the cover off the shower turn the power selector to the OFF position (**fig.17**).



Fig.17



- 4.** With the cover off the shower turn the temperature control to the 5 O'clock position as shown in (**fig.18**).



Fig.18

IMPORTANT: Before finally fitting the cover, the following steps must be taken:

- a. Check the plumbing connections are watertight.
 - b. Check the terminal block screws are fully tightened.
 - c. Make sure the pipe and cable entering the unit do not prevent the cover locating correctly to the backplate.
 - d. Check the power selector is in the OFF position - and the temperature control is turned fully clockwise the '5 o'clock' position.
- Offer the cover to the unit.
 - Carefully guide the cover onto the backplate making sure the wires are not trapped.

NOTE: DO NOT remove the cable tie in this unit.

- Guide the cover into position so that the knob spindle locates correctly (minor adjustment may be necessary to align the knob and spindle).
- Should any difficulty arise, re-check the points above.
- While applying slight pressure to the front cover, secure in place using the three retaining screws.

IMPORTANT

Before normal operation of the shower, it is essential the following commissioning procedure is completed correctly.

COMMISSIONING

- The first operation of the shower is intended to flush out any remaining unit debris and to make sure the heater unit contains water before the elements are switched on.
- This operation must be carried out with the flexible hose screwed to the outlet but **WITHOUT** the showerhead attached, and the outlet from the flexible hose should be directed to waste.
- **IMPORTANT: BEFORE switching on the electric and mains water supplies to the shower** - check that the power selector is in the **OFF** position and the temperature control is turned **fully clockwise**.

NOTE: Failure to follow the instructions above, may cause the PRD to operate if the Start/Stop button is in the 'START' position when the isolator is switched on.

- Turn the power selector to the **COLD** setting (**fig.19**) and wait until water starts to flow from the flexible hose.
- Slowly turn the temperature control **fully anti-clockwise (fig.20)**. It will take about thirty seconds for a smooth flow of water to be obtained while air and any debris is being flushed from the shower. When there is a smooth flow of water, turn the temperature control steadily from **Fully Anti-Clockwise to Fully Clockwise** and back again several times to release any trapped air within the unit.
- Once flushing out has been completed, turn the power selector to the **OFF** position.
- Fit the showerhead to the flexible hose and place in the showerhead holder.
- The shower is now ready for normal operation.

Fig.19

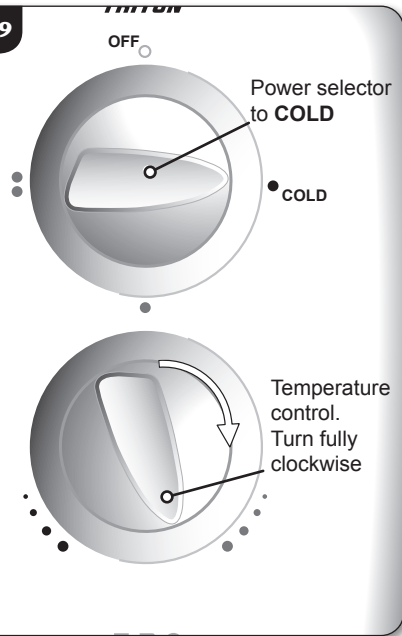
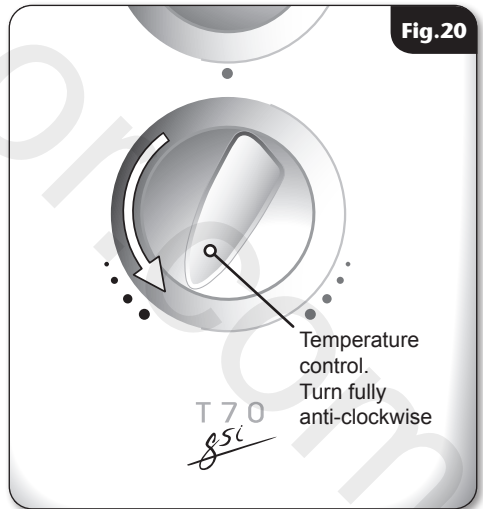

Fig.20



Instructions for installers and service engineers only

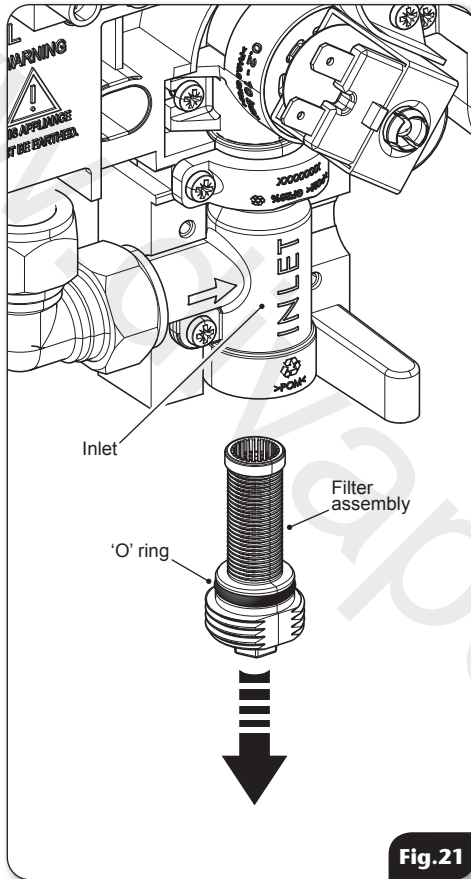

Fig.21

CLEANING THE FILTER

It is recommended that the filter is periodically cleaned in order to maintain the performance of the shower. It is essential that this operation is carried out by a competent person.

- **SWITCH OFF** the electricity and water supply at the mains.
- The inlet filter is situated inside the water inlet fitting (**fig.21**).
- To gain access to the filter, remove the cover and bottom trimplate.
- Unscrew the filter cap from the bottom of the inlet pipe.
- Inspect the 'O' ring for damage when the filter cap is removed.
- When cleaning the filter, **DO NOT** use a sharp object as it will cause damage. It is preferable to use an old toothbrush or similar.
- To reassemble, follow the procedure in reverse.
- Make sure that the sealing 'O' ring is in place.
- **DO NOT** over tighten the filter cap on reassembly.

Important: Switch off the electricity at the mains supply and remove the circuit fuse before attempting any fault finding inside the unit.

| Problem/Symptom | Cause | Action/Cure |
|---|--|--|
| 1 Shower inoperable, no water flow. | 1.1 Interrupted power supply. | 1.1.1 Blown fuse or circuit breaker. Check supply Renew or reset fuse or circuit breaker. If it fails again, consult a qualified electrician. 1.1.2 Power cut? Check other appliances and if necessary, contact local Electricity Supply Company. |
| | 1.2 No mains water supply to shower. | 1.2.1 Check if isolating valves are fully open. Check for a blockage in inlet filter or in pipework. |
| | 1.3 Unit malfunction. | 1.3.1 Have unit checked. Contact Customer Experience. |
| 2 Water too hot. | 2.1 Not enough water flowing through the shower. | 2.1.1 Increase flow rate via temperature control. |
| | | 2.1.2 Blocked showerhead — clean or replace blocked sprayplate in showerhead. |
| | 2.2 Blockage in supply. | 2.2.1 Check if stop valves are fully open. Check if a blockage in the inlet filter. |
| | 2.3 Increase in ambient water temperature. | 2.3.1 Readjust flow rate to give increased flow. |
| 2.3.2 Select economy power. | | |
| 3 Water temperature cycling hot/cool at intervals. | 3.1 Heater cycling on thermal cut-out. | 3.1.1 See 'Water too hot' causes 2.1, 2.2 and 2.3 and their appropriate action/cures. If it continues, contact Customer Experience. |
| 4 Water too cool or cold. | 4.1 Too much flow. | 4.1.1 Reduce flow rate via temperature control. |
| | 4.2 Water pressure below minimum required (see rating label). | 4.2.1 Is water supply mains or tank fed? |
| | | 4.2.2 If tank fed, replumb to mains water supply or see 4.2.4. |
| | | 4.2.3 If mains fed, make sure that mains stopvalve is fully open and that there are no other restrictions in the supply while shower is in use, or see 4.2.4. |
| | 4.2.4 Fit pump to give minimum pressure (see rating label). Contact Customer Experience for advice. | |

Important: Switch off the electricity at the mains supply and remove the circuit fuse before attempting any fault finding inside the unit.

| Problem/Symptom | Cause | Action/Cure |
|---|--|---|
| 4 Water too cool or cold - <i>continued</i> | 4.3 Reduction in ambient water temperature. | 4.3.1 Readjust flow rate to give reduced flow. 4.3.2 Select 'high' power. |
| | 4.4 Electrical malfunction or safety cut-out operated. | 4.4.1 Have unit checked by suitably qualified electrician or contact Customer Experience. |
| 5 Shower varies from normal temperature to cold during use. | 5.1 Water pressure has dropped below minimum required. | 5.1.1 Wait until the water pressure resumes to normal. |
| 6 Pressure relief device has operated (<i>water ejected from PRD tube</i>). | 6.1 Blocked showerhead. | 6.1.1 Clean or replace blocked sprayplate in showerhead and then fit new PRD. |
| | 6.2 Twisted/blocked flexible shower hose. | 6.2.1 Check for free passage through hose. Replace the hose if necessary and fit new PRD. |
| | 6.3 Showerhead not removed while commissioning. | 6.3.1 Fit new PRD. Commission unit with showerhead removed. |
| | 6.4 Water pressure above specified maximum for unit (<i>see rating label</i>). | 6.3.1 Fit pressure reducing valve to inlet and then fit new PRD. |
| 7 Shower fails to shut off. | 7.1 Faulty Start/Stop microswitch. | 7.1.1 Replace microswitch. |
| | 7.2 Debris in solenoid valve. | 7.2.1 Replace solenoid valve. |
| | 7.3 Unit malfunction. | 7.3.1 Have unit checked. Contact Customer Experience. |

NOTE: Identify cause of operation before fitting new PRD unit.
When fitting a new PRD, follow the commissioning procedure.

It is advised all electrical maintenance/repairs to the shower should be carried out by a suitably qualified person.

**In the unlikely event of a fault occurring please contact Customer Experience.
DO NOT remove the shower from the installation.**

To purchase a genuine Triton spare part for your product, please visit

www.tritonshowers.co.uk/spares

for product codes and prices.

Alternatively please call our

Customer Experience team on

024 7637 2222 to order direct.

Please have your model name available.

WEEE Directive – Policy Statement

As a producer and a supplier of electric showers, Triton Showers is committed to the protection of the environment via our own environmental policy and compliance with the **WEEE directive**.

Triton Showers is fully registered with the Environment Agency under the following scheme:

Repic: Producers take-back scheme (PTS), registration number WEE/EJ3466QV

All our electric products are labelled accordingly with the crossed out wheeled bin symbol. This indicates, for disposal purposes at end of life, that these products must be taken to recognised collection points, such as local authority sites/local recycling centres; this will be free of any charges. **Do not return to Triton Showers.**



To START or STOP your shower.

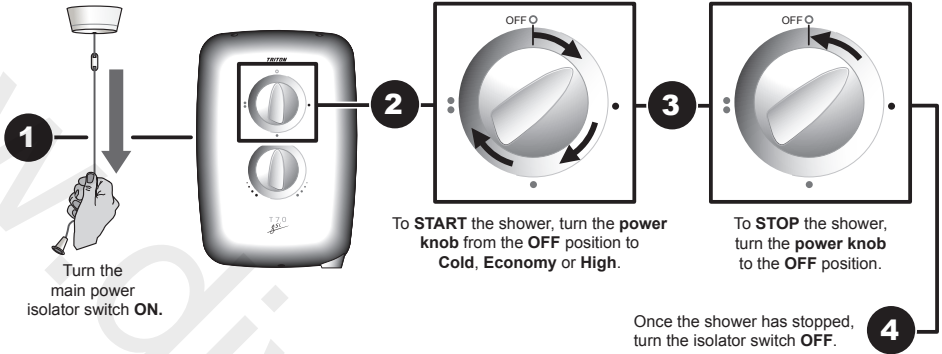

To alter the Power and Temperature of your shower.

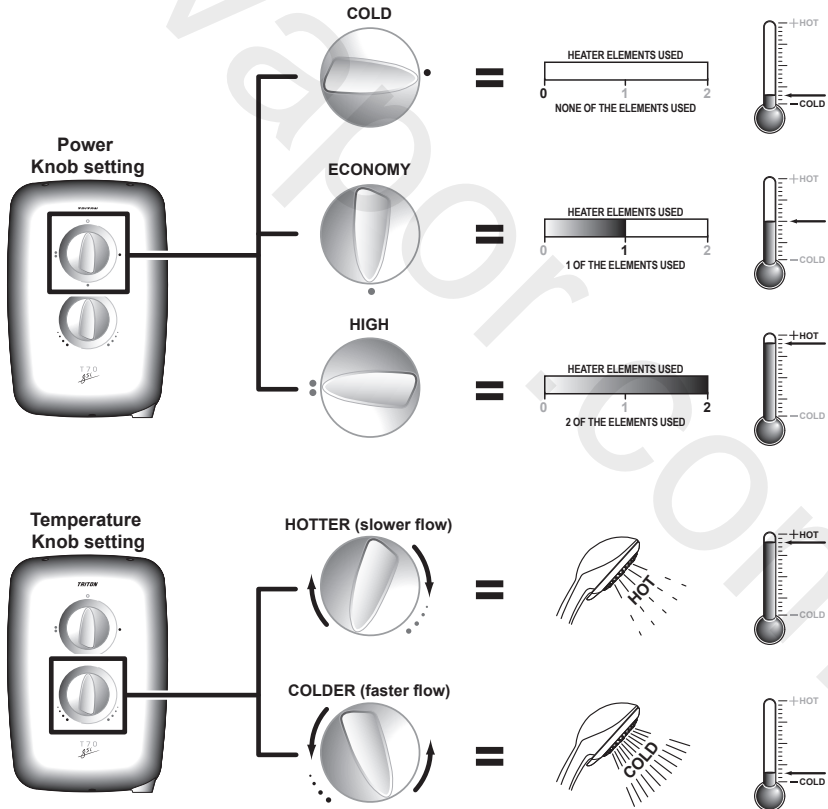

www.divapor.com

www.divapor.com

UK SERVICE POLICY

In the event of a product fault or complaint occurring, the following procedure should be followed:

DO NOT REMOVE THE PRODUCT

1. Telephone Customer Experience on **024 7637 2222** having available your details including post code, the model number and power rating of the product, together with the date of purchase and, where applicable, details of the particular fault.
2. If required, the Customer Experience Advisor will arrange for a qualified engineer to call.
3. All products attended to by a Triton service engineer must be installed in full accordance with the Triton installation guide applicable to the product. Every product pack contains an installation guide, however, they can also be downloaded free at www.tritonshowers.co.uk.
4. Our engineer will require local parking and if a permit is required, this must be available to the engineer on arrival at the call.
5. If loft access is required for isolation or to complete a repair, the loft must have a fixed access ladder and be boarded, with appropriate lighting from the access point to and around the repair area.
6. It is essential that you or an appointed representative, who must be over 18 years of age, is present for the duration of the service engineer's visit. If the product is in guarantee you must produce proof of purchase.
7. Where a call under the terms of guarantee has been booked and the failure is not product related (i.e. scaling and furring, incorrect water pressure, pressure relief device operation or electrical/plumbing installation fault) a charge will be made. A charge will also be issued if nobody is at the property when the service engineer calls or adequate parking/permit is not available.
8. If the product is no longer covered by the guarantee an up-front fixed fee will be charged before the site visit.
9. Your receipt must be retained as proof of purchase. Should proof of purchase not be available on an 'in-guarantee' call, or should the service engineer find that the product is no longer under guarantee, the engineer will charge the same fixed price and will request payment prior to departing. If payment is not made on the day an administration charge will be added to the fixed charge.
10. If a debt is outstanding from a previous visit, or from any other Triton purchase, Triton reserves the right to withhold service until the debt has been settled.
11. Triton takes the health, safety and wellbeing of its employees very seriously and expects customers to treat all staff members with respect. Should any employee feel threatened or receive abuse, either verbally or physically, Triton reserves the right to withhold service.

Replacement Parts Policy

In line with AMDEA guidelines, Triton retains functional spares for as long as there is a market for them and in most cases, well beyond. Due to the vast array of product types, the life cycle of products can vary and therefore so can the length of time parts can be supplied. Spare parts can be ordered via our online spare parts store or by telephoning Triton Customer Experience team on **024 7637 2222**. Payment should be made by credit / debit card (excluding American Express or Diners Card). Payment can also be made by pre-payment of a pro-forma invoice, by cheque or postal order.

Telephone orders are based on information given during the call. Before contacting Triton, please verify your requirements using the Triton website or your professional installer. Triton cannot accept liability for incorrect part identification.

Triton Showers
Triton Road
Nuneaton
Warwickshire, CV11 4NR

Triton is a division of Norcross Group (Holdings) Limited

Triton reserve the right to change product specification without prior notice. E&OE. © TRITON SHOWERS 2020

TRITON UK STANDARD GUARANTEE

This guarantee applies only to products installed within the United Kingdom and does not apply to products used commercially. This guarantee does not affect your statutory rights.

With the exception of accessories, Triton guarantee the product against all manufacturing defects for a period of **2 years** (for domestic use only) from the date of purchase, provided that it has been installed by a competent person in full accordance with the fitting instructions.

All accessories such as shower heads, hoses and riser rails carry a **1 year** parts only guarantee against manufacturing defects.

Any part found to be defective during this guarantee period we undertake to repair or replace at our option without charge, so long as it has been properly maintained and operated in accordance with the operating instructions and has not been subject to misuse or damage. This product must not be taken apart, modified or repaired except by a person authorised by Triton.

What is not covered:

1. Breakdown due to:
 - a)** use other than domestic use by the property occupants;
 - b)** wilful act or neglect;
 - c)** any malfunction resulting from the incorrect use or quality of electricity, gas or water or incorrect setting of controls;
 - d)** failure to install in accordance with this installation guide.
2. Claims for missing parts once the product has been installed.
3. Repair costs for damage caused by foreign objects or substances.
4. Total loss of the product due to non-availability of parts.
5. Compensation for loss of use of the product or consequential loss of any kind.
6. Call out charges due to an abortive visit or where no fault has been found with the appliance.
7. The cost of repair or replacement of isolating switches, electrical cable, fuses and/or circuit breakers or any other accessories installed at the same time. Replacement of the Pressure Relief Device that only activates when the shower outlet is blocked is also excluded.
8. The cost of routine maintenance, adjustments, overhaul modifications or loss or damage arising therefrom, including the cost of repairing damage, breakdown, malfunction caused by corrosion, furring, frost or exposure to freezing conditions.
9. Callout charges where the water supply cannot be isolated, this includes consequential losses arising from unserviceable supply valves, or inaccessible product or valves located in a loft space without suitable access.

For the latest Terms & Conditions please see:

www.tritonshowers.co.uk/terms

PLEASE NOTE PRODUCT REGISTRATION IS ONLY AVAILABLE TO UNITS PURCHASED & INSTALLED IN THE UK

Customer Experience: **024 7637 2222**

Trade Installer Hotline: **024 7637 8344**

www.tritonshowers.co.uk

E-mail: serviceenquiries@tritonshowers.co.uk

E-mail: technical@tritonshowers.co.uk