

MAINTENANCE

Problem	Solution
After installation shower only runs HOT or COLD and will not mix.	Check Hot & Cold supplies are plumbed the correct way round.
Shower will not run hot enough when first installed	Check temperature and of hot and cold entering the valve. Check for debris in the pipe work or valve inlets.
Cold water running back through the valve into the hot water system.	Check and clean the check valve cartridges and filters located under the check valves.

10-YEAR GUARANTEE

We have complete confidence in this Tavistock product and as such it is offered with a 10-year guarantee against defects in manufacture. This valve must be fitted by a competent installer. If in doubt seek advice from a qualified professional. The guarantee requires that this product be used in the manner for which it was intended and that it is installed & maintained in accordance with the fitting instructions and local water bylaws. The guarantee covers products in domestic use only. Always ensure this product is fully tested before concealing valves into the wall. On installation ensure that the valve and valve inlet threads can be removed or serviced in accordance with UK regulations. The guarantee is invalidated should the valve be damaged by water borne debris. Make sure that supply pipes are clear of any debris prior to installation, this is particularly important on new plumbing installations. In the unlikely event that this product should fail during the guarantee period we will either replace the faulty part or the complete unit as appropriate. This guarantee excludes normal wear and tear. This guarantee covers failure of the thermostatic cartridge within the first 2 years of purchase only. Replacement cartridges are available to purchase by contacting the Tavistock Customer Service team. Failure to follow the terms outlined above will invalidate this guarantee. Proof of purchase will be required to validate any guarantee claims.

TAVISTOCK
inspiring bathrooms

INDEX & QUANTUM
2 WAY DIVERTER VALVE
Installation & aftercare instructions

Please retain for future reference

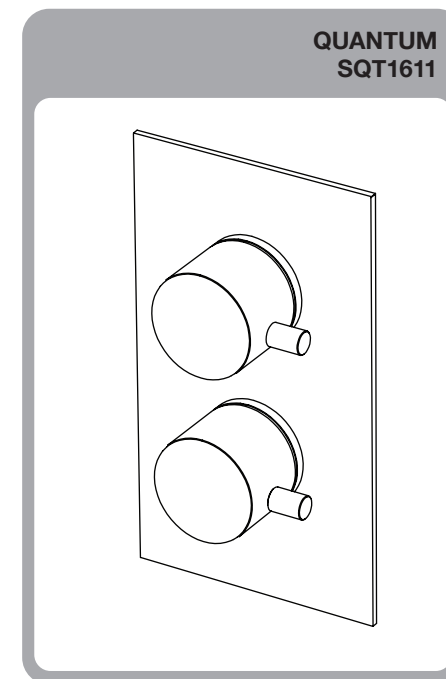
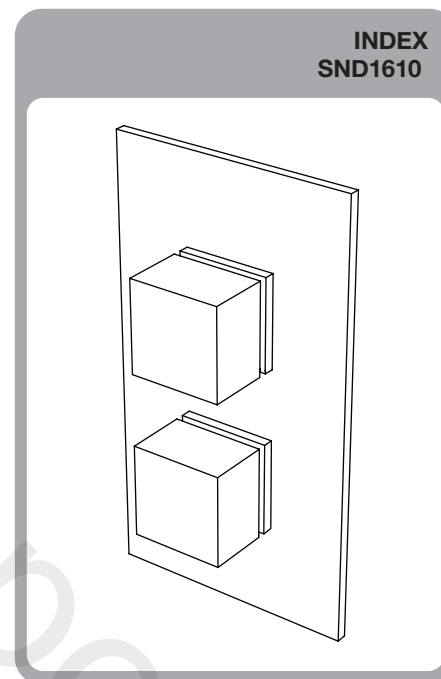

We recommend that this product should be fitted by a qualified plumber.

FLOW RATES

PRESSURE	0.1	0.2	0.3	0.4	0.5	1	2	3	4
L per MIN	5.75	7.81	9.37	10.73	11.97	17.16	24.29	30.02	34.5

For installation problems or advice please call our helpline number **01225 787 870**

TAVISTOCK
inspiring bathrooms

Customer Services, Tavistock, Brassmill Lane Trading Estate, Bath, BA1 3JF
TEL: 01225 787 870 | FAX: 01225 448 877
Email: tavistock@roperrhodes.co.uk | Web: www.tavistock-bathrooms.co.uk

INTRODUCTION

This guide provides instruction for the installation operation and maintenance of your Tavistock concealed 2 way diverter valve.

This shower valves must be installed in accordance with the Water Supply (Water Fittings) Regulations 1999 .

OPERATING CONDITIONS OF USE

Before installation the operating conditions of use must be checked. The table below contains details of the necessary conditions of operation. This valve is suitable for use in both low pressure (BS 1287) and high pressure (BS 1111) operating conditions.

UNBALANCED WATER SUPPLY

Valves must always be operated within either the range for BS 1287 OR BS1111 as described in the table below. Valves cannot operate effectively where a hot or cold pressure system crosses the boundaries of the two ranges. In addition the maximum ratio of unbalanced hot and cold water pressures for the valves to operate effectively is 2:1. Hot or cold pressure must be reduced or boosted so as to work within the required range.

MAXIMUM WATER PRESSURE

Concealed Dual Control shower valves are suitable for use with all water supply systems up to a maximum of 4.0 Bar. Operating pressures above 4.0 Bar will require the installation of pressure reducing valves.

	Low Pressure BS1287	High Pressure BS1111
MAX Static (BAR)	10	10
Flow Pressure (BAR) Hot and Cold	0.1 - 1.0	0.1 - 4.0
Hot Supply (°C)	55 - 65	55 - 65
Cold Supply (°C)	MAX 25	MAX 25
Mixed Water (°C)	MAX 44	MAX 44

VALVE INSTALLATION GUIDELINES AND COMPLIANCE

The valve must be installed so that it is readily accessible for commissioning and maintenance. The valve must be installed with isolation valves on both the hot and cold water systems as close as possible to the valve; so as to allow the valve to be commissioned and tested correctly. The valve is supplied with integral strainers on the hot and cold water supplies therefore in-line strainers should not be required. The valve is fitted with integral check valve cartridges which command the water supply, therefore the thermostatic valve is protected against cross-flow due to unbalanced line pressures as required by the Water Supply (Water Fittings) Regulations 1999.

TESTING

It is recommended that showers do not exceed 42°C. The valve temperature should never exceed 46°C. After commissioning, carry out the cold failure test to ensure the valve is operating correctly and check the valve after installation to ensure it operates at the correct outlet temperature.

SETTING THERMOSTAT TEMPERATURE & INSTALLATION OF HANDLES

Fitting the Temperature Control Handle:

The valve is factory set to reach a maximum temperature of 42°C. Attach the handle to the temperature spindle and secure in position so that when the valve is at its hottest, the handle arm is pointing towards the 'HOT' marking on the cover plate.

Fitting the Flow Control Handles:

Fit the remaining handle onto the on-off flow control spindle. Secure the handle so that when the flow is shut off the arm of the handle is pointing to the 'OFF' position.

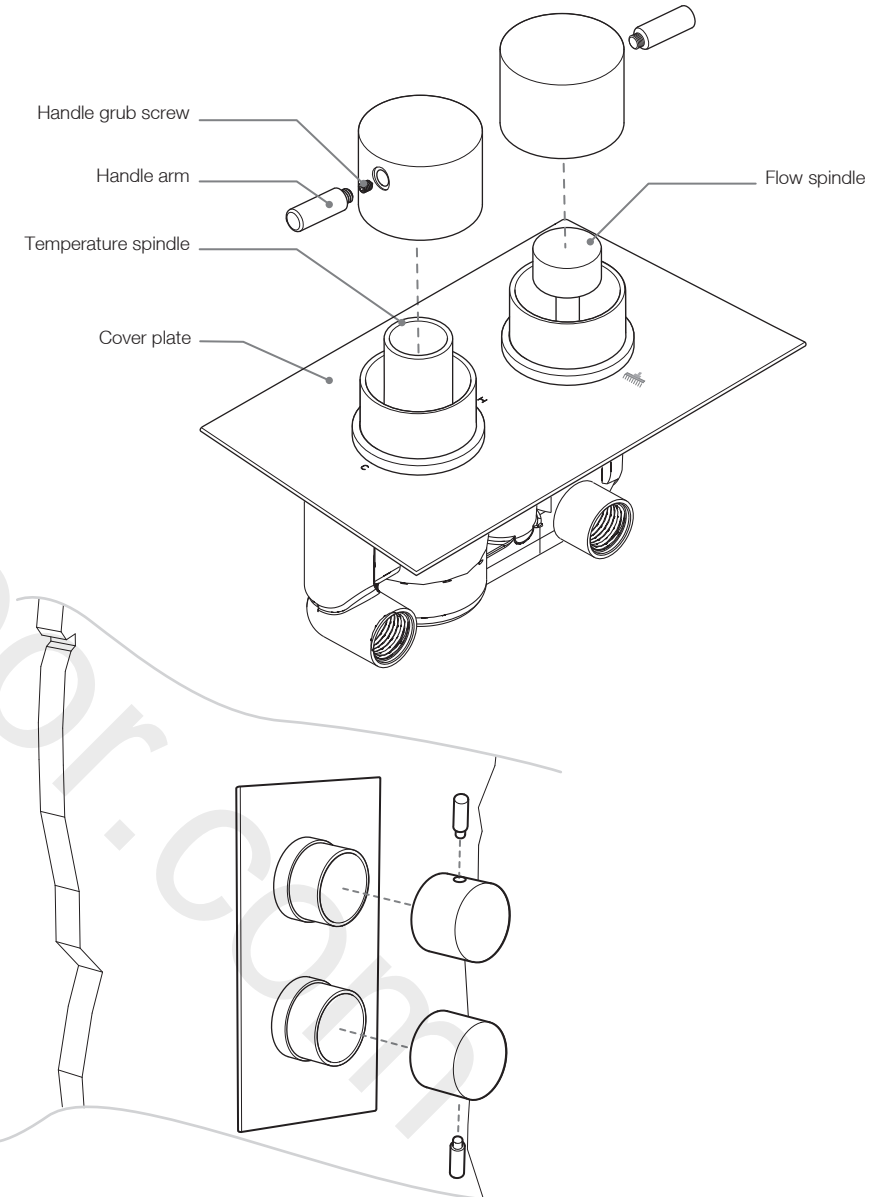

10. Apply a small bead of silicone behind the front cover plate and slide over the body into position. Smooth off against the wall finish.

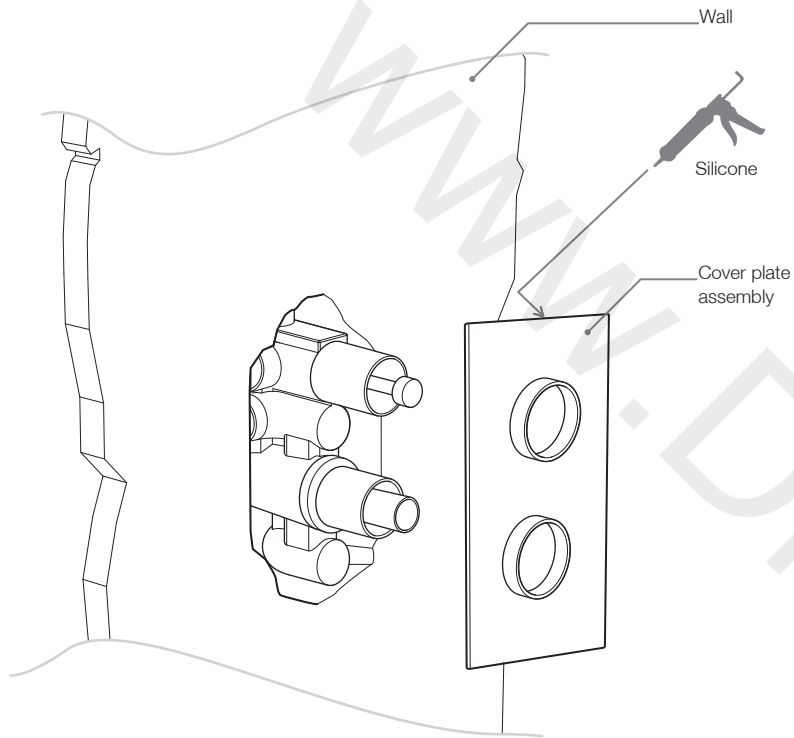

TESTING METHOD

The valve should be tested to ensure correct operation at commissioning and thereafter at stated intervals decided by the user but never at greater than 12 monthly intervals. The testing will only require a normal thermometer with a scale greater than 65°C. The temperature sensitive element of the thermometer should always be fully inserted into the water flow.

1. Measure the mixed water temperature.
2. Carry out a cold fail/safe shut-off test by using the isolation valve to shut off the water to the cold supply. Wait 5 seconds, if water is still flowing check that the water temperature is below 42°C. The flow should stop or reduce to a trickle.
3. Open the cold water isolation valve and measure mixed water temperature. If there is no significant change from the original settings and fail/safe shut off is functioning the valve is working correctly and no further service is required. If the fail/safe function does not work, a full service or re-commissioning is required. We recommend that in these circumstances you contact a plumber for advice as servicing should only be undertaken by a competent person.

WATER SUPPLY - (WATER FITTINGS) REGULATIONS 1999

This valve complies with the requirements of the above regulations and installation should be carried out in strict compliance with them.

COMMISSIONING

Most problems associated with the operation of thermostatic shower valves are caused by debris in the new pipe work getting into the thermostat. These problems are easily avoided by thoroughly flushing the pipe work BEFORE the shower valve is fitted. Ensure the valve is fully tested and working before final fix of the cover plate and handle assembly.

OPERATING

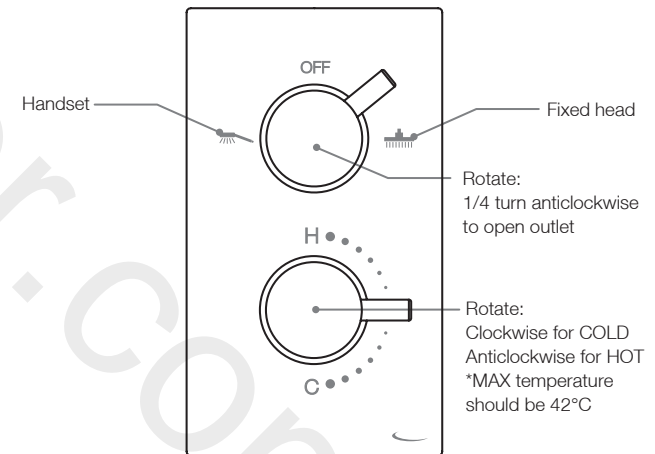

IMPORTANT

ENSURE TO CONNECT RIGHT OUTLET TO FIXED HEAD AND LEFT OUTLET TO HANDSET (VIA WALL ELBOW) ACCORDING TO SYMBOLS ON COVER PLATE

MOUNTING THE SHOWER VALVE

1. Determine the mounting position for the shower valve.
2. Prepare the recess in the wall in which to mount the valve. Ensure the cover plate will hide the cut recess after installation of the valve.

The depth of the recess for the valve should be: MIN 85mm, MAX 100mm.

3. Mount the valve in the recess using the fixing lugs and supplied fixing screws to secure (see diagram below).
4. When the valve is securely mounted into the wall make the plumbing connections using PTFE tape. Inlets and outlets are all tapped 1/2" BSP. **IMPORTANT:** Do not use tapered threaded adaptors, this may damage the valve body.
5. Connect the water outlet to the valve outlet connections e.g. shower handset via wall elbow and shower head.
6. Turn on the water supply and test all pipe work for leaks.
7. Remove Hot & Cold check valves, flush out the installation, clean the filters and refit. Re-check pipe work and valve for leaks.

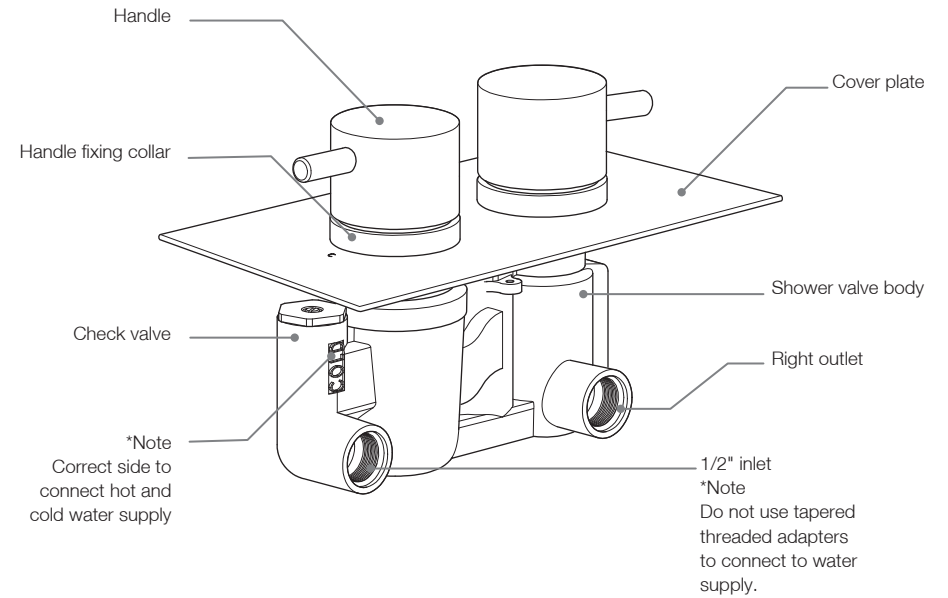
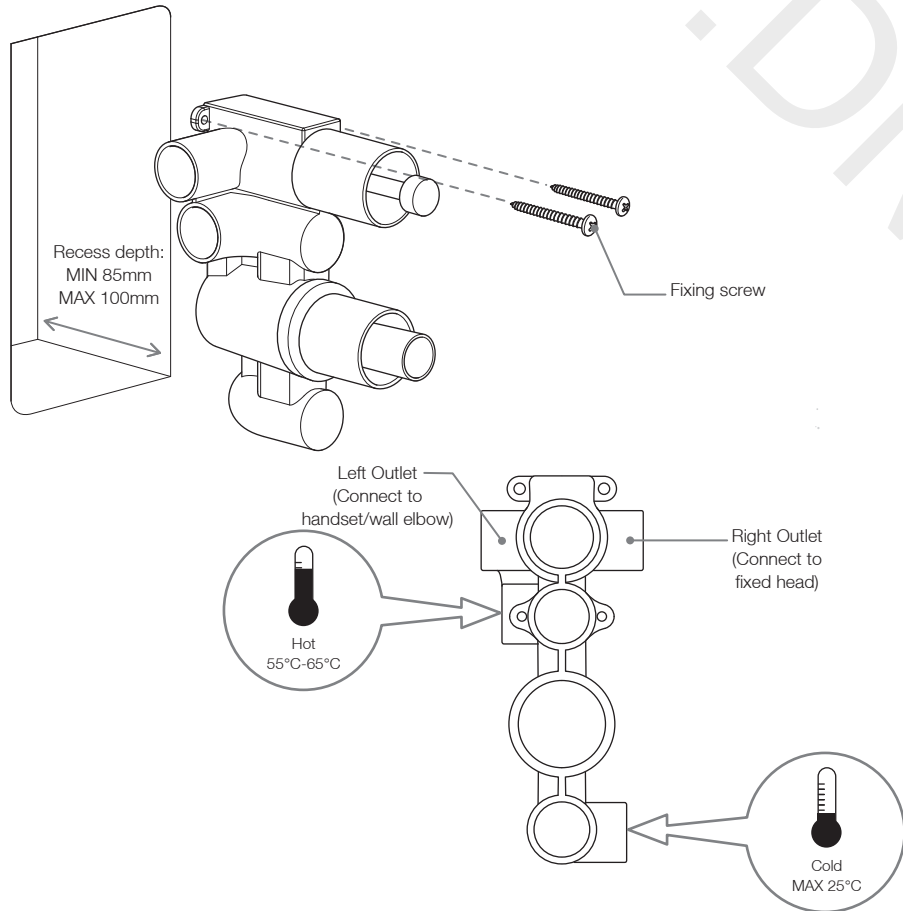

ASSEMBLY OF COVER PLATE

9. The valve is supplied with plastic protection covers. These can be left in place to protect the thermostat until assembly of the plate and handles and final commissioning of the valve is required. At this time, remove the protection cover whilst keeping the chrome retaining sleeve in place over the thermostat body.

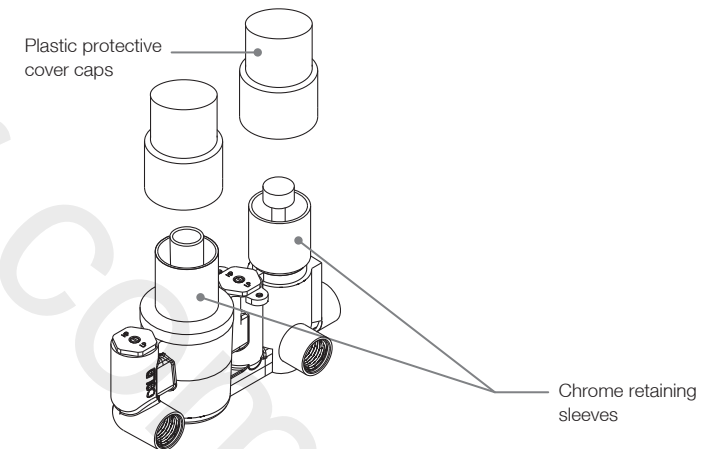

Please retain for future reference

BEFORE YOU START

Wear suitable eye protection when drilling. Take care when using power tools near water - the use of a residual current device (RCD) is advised. Beware of hidden cables or pipes. When drilling tiled surfaces, a piece of masking tape applied to the wall before marking out the fixing holes will stop the drill wandering. Wall plugs provided are suitable for Stone or Brick walls only. For other wall types use appropriate wall plugs. If in doubt consult an expert.

We recommend these products are installed by a qualified plumber. Identify all components shown in the diagrams below and ensure they are all present. In the unlikely even you find there are parts missing please contact Tavistock using the contact details at the foot of the page.

FIXED ARM

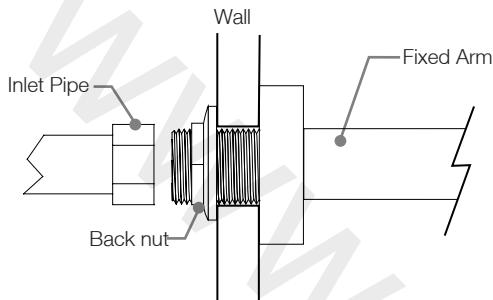

1. Secure arm in place using the back nut provided (See diagram above)
2. Connect inlet pipe work to fixed arm using G1/2" BSP fitting. Use thread sealing tape where necessary.

IMPORTANT: Test arm for leaks prior to finishing installation.

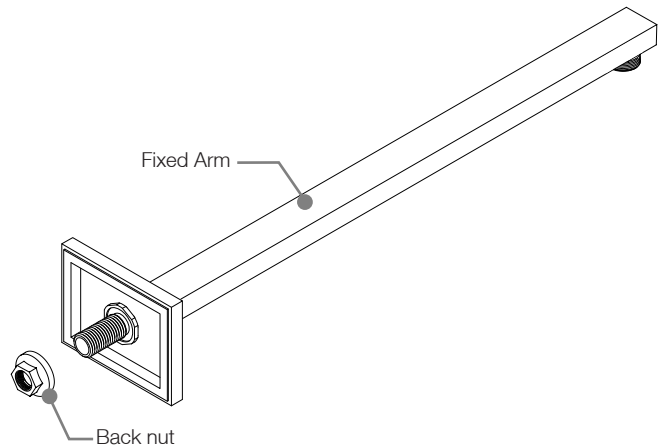

WALL ELBOW

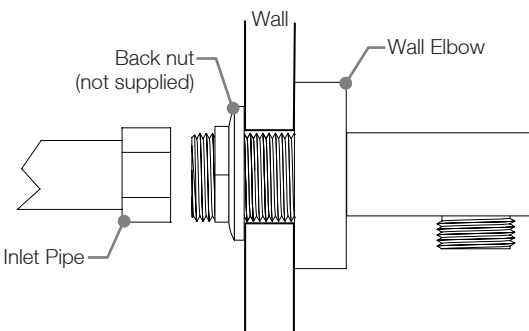

1. Secure wall elbow in place using the back nut provided (See diagram)
2. Connect inlet pipe work to wall elbow using G1/2" BSP fitting. Use thread sealing tape where necessary.

IMPORTANT: Test wall elbow for leaks prior to finishing installation.

RAIL

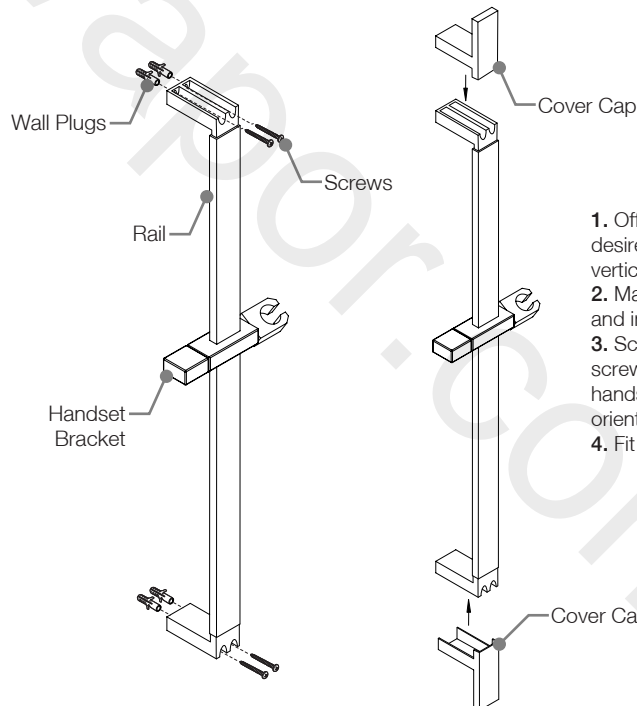

1. Offer rail up to the wall in desired location. Ensure it is vertical using a spirit level.
2. Mark screw locations. Drill and install wall plugs.
3. Screw rail in place with screws provided. (Ensure handset bracket is in correct orientation.)
4. Fit cover caps.

ACCESSORIES

Fit handset, hose and fixing heads. Ensure all connections are secure and check for leaks. Use thread sealing tape where necessary.

MAINTENANCE AND AFTERCARE

Whilst this item has a high quality durable finish, it should nevertheless be treated with care. Surfaces should be cleaned using only a soft damp cloth and clean water then dried using a soft cotton cloth. Bath cleaning products, even non-scratch ones, could damage the finished surface.

For installation problems or advice, please contact customer services. See details below.