

TRITON

INSTAFLOW

Unvented Stored
Water Heater

**REGISTER ONLINE
ENTER A PRIZE DRAW**

**WIN
£100**

RETAIL VOUCHERS

VISIT OUR WEBSITE TODAY

*PRODUCT REGISTRATION IS ONLY AVAILABLE
TO UNITS PURCHASED & INSTALLED IN THE UK*

FOR YOUR SERVICE REFERENCE

NOTE DOWN THE PRODUCT CODE BELOW
(FROM THE FRONT OR TOP OF THE BOX)

ALTERNATIVELY REGISTER BY TEL: 024 7637 8321



Available in 3
tank capacities

IMPORTANT SAFETY ADVICE

During installation of the water heater the supplied pressure reducing valve must be fitted.

Failure to use genuine Triton parts may cause injury and invalidate your guarantee.

INSTALLATION AND OPERATING INSTRUCTIONS

Please read this book thoroughly and familiarise yourself with all instructions before commencing installation and keep it for future reference.

The water heater installation **MUST** be carried out by a suitably qualified person, **in the sequence of this instruction book.**

PLEASE READ THIS IMPORTANT SAFETY INFORMATION AND GUIDANCE NOTES

Products manufactured by Triton are safe and without risk provided they are installed, used and maintained in good working order in accordance with our instructions and recommendations. This book contains all the necessary fitting and operating instructions for your water heater. Please read them carefully and read through the whole of this book before beginning the installation. Care taken during the installation will provide a long, trouble-free life from your water heater.

The installation must be carried out by a suitably qualified person.

This product complies with the requirements of EN 60335-1 and EN60335-2-21.

WARNINGS

DO NOT operate the water heater if frozen or suspected of being frozen. It must thaw out before use.

DO NOT operate the water heater if it becomes damaged.

DO NOT operate the water heater if water ceases to flow during use or if water has entered inside the unit because of an incorrectly fitted cover.

DO NOT use the water heater for showering or hairdressing applications.

DO NOT exceed the rated water pressure of the water heater.

DO NOT plug in the water heater before it is filled with water and the commissioning procedure has been completed.

ELECTRICAL SAFETY

Connection to the mains electric supply must only be via the supplied plug.

If the supply cord is damaged, it must be replaced immediately by the manufacturer, its service agent or similarly qualified persons in order to avoid a hazard.

Isolate the mains electrical and water supply before removing the maintenance cover of the water heater.

USER SAFETY

This appliance can be used by children aged from 8 years and above and persons with reduced physical, sensory or mental capabilities or lack of experience and knowledge if they have been given supervision or instruction concerning use of the appliance in a safe way and understand the hazards involved. Children should be supervised to ensure that they do not play with the appliance. Cleaning and user maintenance shall not be made by children.

IMPORTANT

If the water heater will not be in use for a period of more than 3 days and installed in premises where the temperature could drop below 4°C, the water must be drained from the water heater.

The water heater is designed for installation with the inlet/outlet pipes pointing upwards. Under no circumstances should the water heater be mounted upside down with the inlet/outlet pipes pointing downwards.

PLUMBING REQUIREMENTS

DO NOT install where the water heater could become frozen.

DO NOT connect to any form of fitting not recommended by the manufacturer.

DO NOT use jointing compounds on any pipe fittings for the installation.

DO NOT solder fittings near the water heater as heat can transfer along the pipework and damage the the water heater.

Ensure that the mains water supply meets the requirements listed.

A suitable isolating valve (complying with Water Regulations and Bylaws)

MUST be fitted to the cold water supply to the water heater as an independent means of isolating the water supplies should maintenance or servicing be necessary. If this isolator is fitted in a loft space, the loft must have a fixed access ladder and be boarded, with appropriate lighting from the access point to the isolator.

Flush pipework to clear the system of debris and check for leaks before connecting to the water heater.

UNVENTED STORED WATER HEATER

TECHNICAL SPECIFICATIONS			
	5 litre	10 litre	15 litre
ELECTRICAL			
Nominal power - rating at 230V - 240V	1.5kW - 1.65kW	2.0kW - 2.2kW	2.0kW - 2.2kW
PLUMBING			
Supply source	Mains pressure cold water only		
Minimum operating pressure	50 kPa (0.5 bar)		
Flow to the inlet of the water heater for full performance	8 l/min		
Maximum operating pressure	600 kPa (6 bar)		
Minimum inlet temperature	5°C		
Inlet connection	1/2" BSP		
Outlet connection	1/2" BSP		
MATERIALS			
ABS	Front and rear cover, maintenance cover.		
Minerally insulated corrosion resistant metal sheathing	Elements		
STANDARDS and APPROVALS			
Splashproof rating	IPX4		
Safety	Complies with the requirements of current British and European safety standards for household and similar electrical appliances		
BEAB	Complies with requirements of the British Electrotechnical Approvals Board (BEAB)		
CE	Meets with Compliance with European Community Directives (CE)		

GENERAL

This water heater is designed to supply hot water to domestic and light commercial facilities and must be installed in compliance with Water Regulations/Bylaws and building regulations.

Installation must be in accordance with the current IEE Wiring Regulations BS 7671 and Part P of the Building Regulations.

This water heater must not be altered or modified in any way as this will invalidate your guarantee.

This appliance is intended to be permanently connected to the water mains and not connected by a hose set.

The water heater must be filled with water before being switched on electrically.

Details of product installation can be found from page 10 to 13 inclusive.

PRESSURE RELIEF VALVE (83317580)

The pressure relief valve (PRV) supplied with this water heater **MUST** be fitted. This is a safety critical item and only the Triton 6 bar pressure relief valve (83317580) should be fitted.

Details of product installation can be found from page 10 to 13 inclusive.

Water may drip from the discharge pipe of the PRV and this pipe must be directed to waste and in a continuously downward direction, in a frost free environment.

The PRV is to be operated regularly to remove lime deposits and to verify it is not blocked.

PRESSURE REDUCING VALVE

On sites where the running pressure is above 600 kPa (6 bar), the Triton pressure reducing valve (86005880) must be fitted in the cold mains supply pipework.

PRODUCT DESCRIPTION

This product consists of a body, plastic control panel and safety pressure relief valve.

DRAINING PROCESS

If it becomes necessary to drain the product, follow the procedure below.

1. Cut off the power supply.
2. Turn on the hot water tap to drain water for 2 minutes (discharge the hot water).
3. Turn off cold water supply.
4. Screw out the water inlet and outlet pipes.
5. Turn the water heater upside down with its inlet and outlet facing down.

Caution: Heavy product. Handle with care when draining water from the product.

Fig.1 Wiring Diagram

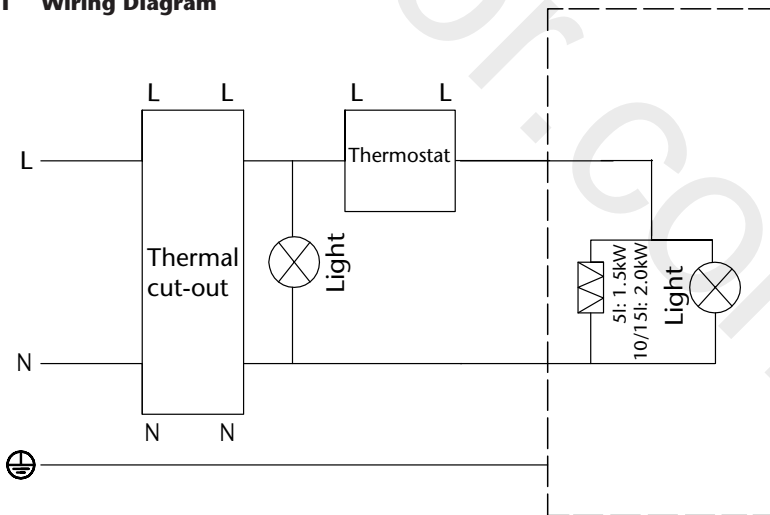



UNVENTED STORED WATER HEATER

CONTENTS

PAGE

IMPORTANT SAFETY INFORMATION & GENERAL GUIDANCE NOTES (<i>please read</i>).....	2 - 5
TECHNICAL SPECIFICATIONS.....	7
DIMENSIONS	8 - 9
SITE OF THE WATER HEATER.....	10 - 11
INSTALLATION.....	12
LEAK TESTING	13
COMMISSIONING.....	13
OPERATING THE WATER HEATER	14
MAINTENANCE.....	15
FAULT FINDING.....	16
SPARE PARTS.....	17
GUARANTEE, SERVICE POLICY, ETC.....	REAR COVER

Model		5 litre	10 litre	15 litre
Declared load profile		 XXS	 XXS	 XXS
Energy efficiency class		B	B	B
Energy efficiency	%	32	32	32
Annual electricity consumption	kWh	576	576	576
Sound power level	dB	15	15	15
Daily electricity consumption	kWh	2.781	2.781	2.781
Thermostat temperature settings	°C	60+/-5	60+/-5	60+/-5
Thermostatic position (out of box)		ECO	ECO	ECO

UNVENTED STORED WATER HEATER

DIMENSIONS

5 LITRE

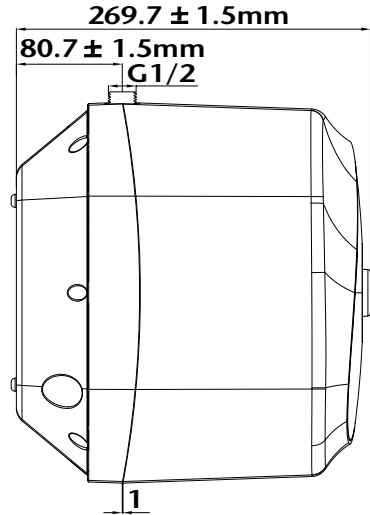
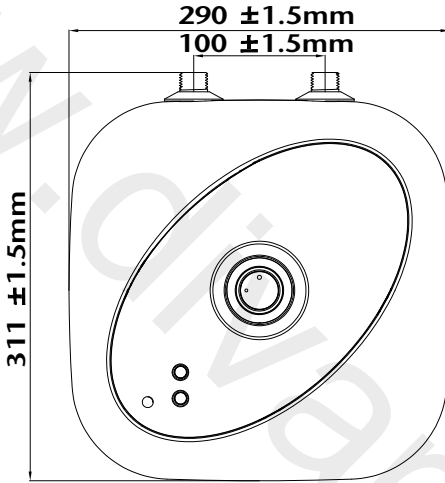

10 LITRE

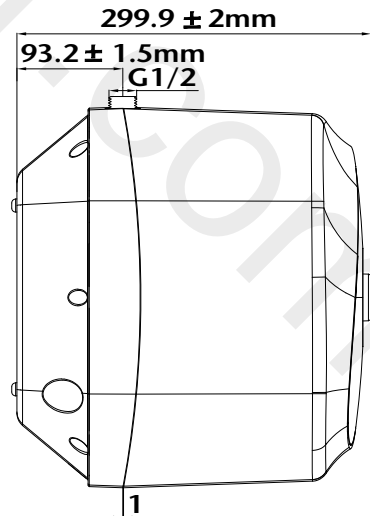
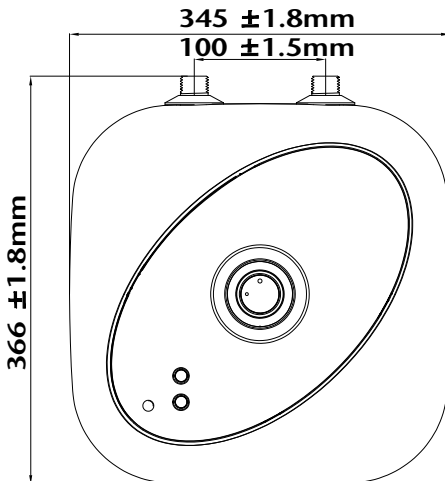

DIMENSIONS

15 LITRE

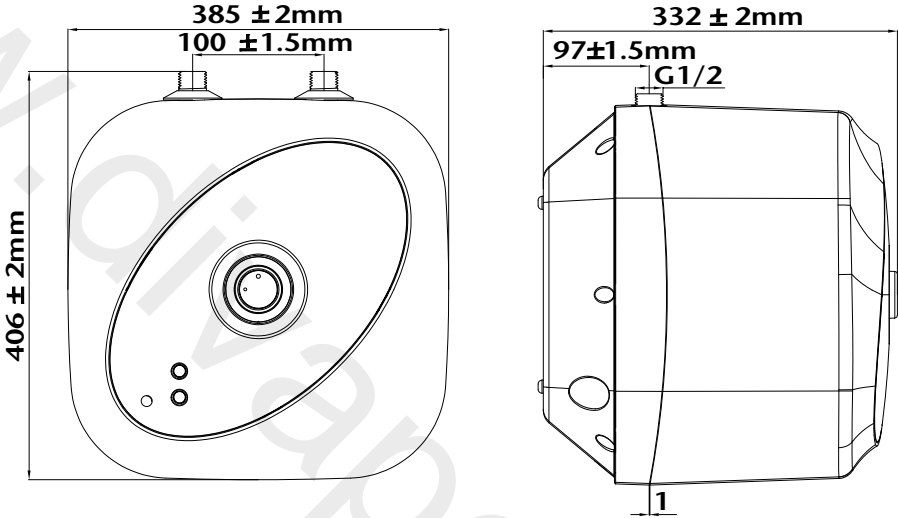

BOX CONTENTS

Before beginning the installation please check the contents to make sure all parts are present.

1. Installation and operating instructions
2. Instaflow water heater
3. Wall bracket
4. 1.2m cable fitted with UK plug
5. Screws and wall plugs (suitable for brick wall)
6. Pressure relief valve
7. Dielectric junctions

OPTIONAL ACCESSORIES

- Kit A - 2 litre expansion vessel and non-return valve
- Kit B - 3.5 bar pressure reducing valve
- Kit C - Tundish

PRODUCT INSTALLATION

SITING OF THE WATER HEATER

The installation of this water heater must be carried out in accordance with Building Regulations and Water Regulations/Bylaws. Please consider the following when choosing the location for the water heater.

- The unit should be installed as near as possible to the outlet point in order to reduce heat loss along the pipes.
- The installation location must always be clean and dry.
- The water heater should be mounted on to a solid wall - **consideration must be given to product weight when filled with water.**
- Install the water heater where it will be close to the water source and power socket.
- Guarantee that there is clear access to the front maintenance panel of the water heater.
- Take care to avoid cables and pipes within the wall.
- If a non-return valve is fitted in the inlet feed to the water heater the installation should also include a 3.5 bar pressure reducing valve.

Note: For best performance, a minimum flow of 8 litres per minute should be available at the inlet.

PLUMBING REQUIREMENTS

The diagrams on page 11 (**fig.2** and **fig.3**) show the plumbing requirements, where expansion cannot be accommodated within the pipework the appropriate accessory kits must be procured.

Triton recommends the use of copper pipe, the use of other materials is beyond the scope of this installer guide.

UNVENTED STORED WATER HEATER

Fig.2 Typical installation with expansion allowed in the incoming pipework

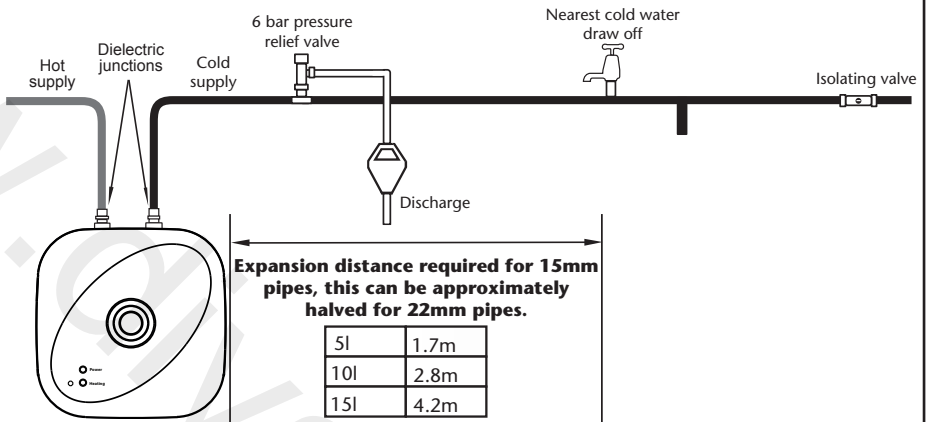

Do not fit stop cocks or isolating valves within the distance required for expansion. If mains pressure is over 600 kPa (6 bar) and a pressure reducing valve is needed, an expansion control kit must be fitted regardless of expansion pipework installed.

Fig.3 Typical installation where the expansion cannot be accommodated in the incoming pipework

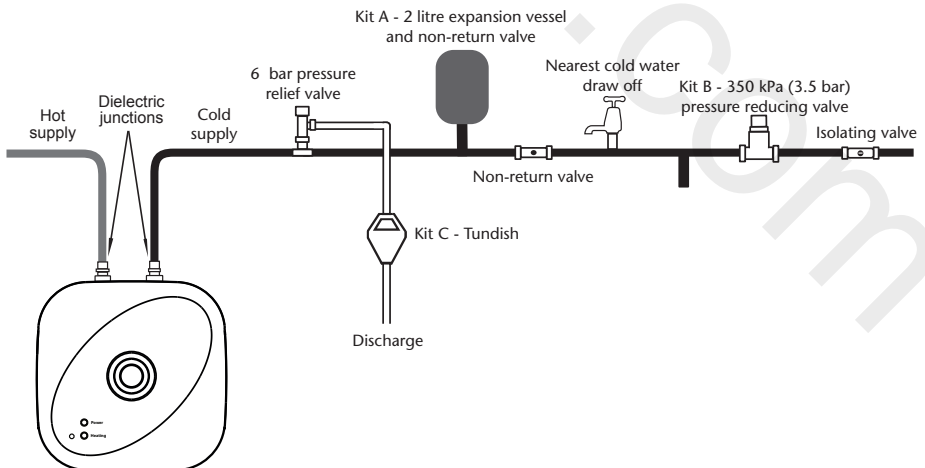

FIT THE BRACKET TO THE WALL

Using the bracket as a template, mark the fixing holes on the wall, ensuring the bracket is level.

Drill and plug the wall. An appropriate drill bit should be used.

Note: If the wall is plasterboard or a soft building brick please select an appropriate wall fixing method; this is beyond the scope of this installation guide.

Screw the bracket to the wall (**fig.4**).

FIT THE HEATER

Slide the water heater on to the bracket (**fig.5**) using the top bracket holes on the water heater (**fig.6**).

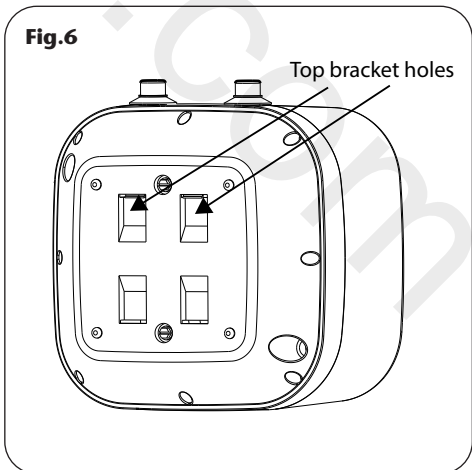
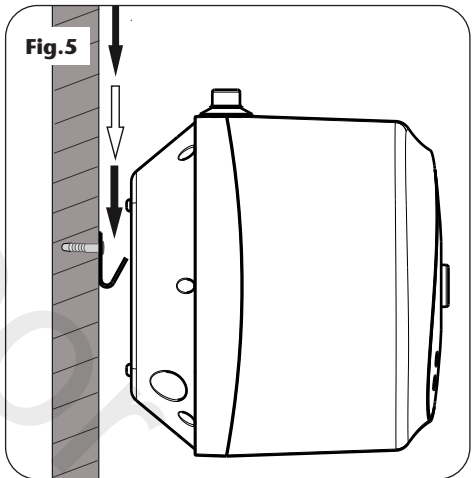
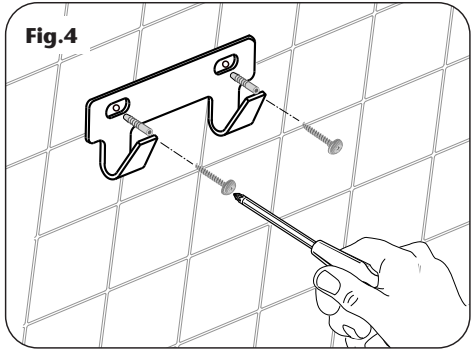

LEAK TESTING

Flush out the pipework to remove any debris. Open the water isolating valves and check for leaks.

Rectify any leaks found before proceeding with commissioning.

COMMISSIONING

Important: This procedure must be completed with the electricity switched **OFF** at the isolating switch.

Fully open the outlet tap and allow the water heater to fill until a smooth water flow is obtained; allow time for air and any debris to be flushed from the unit. Once flushing out has been completed, stop the water flow by turning off the outlet tap.

Plug the water heater in and switch on the electricity supply. The water heater is now ready for normal use.

UNVENTED STORED WATER HEATER

OPERATING THE WATER HEATER

1. Power Light: Indicates that power is supplied to the water heater.

2. Heat Light: Indicates that the water heater is heating the water.

3. Temperature Selection: The water heater has three temperature settings. **Approximate** heating times and temperatures are shown in the chart below.

The element heats the water in the tank and is controlled by the thermostat, automatically maintaining the pre-set temperature. The control panel incorporates an adjustable thermostat and an indicator light.

The thermal cut-out switches off the power supply should the water temperature reach excessive values. If this device is activated, you should call our Triton Customer Experience helpline.

Pressure will increase when the temperature increases by releasing the excess pressure through the drain outlet. Excess water exiting into the drain during the heating process is a normal event that must be taken into consideration when the water heater is installed.

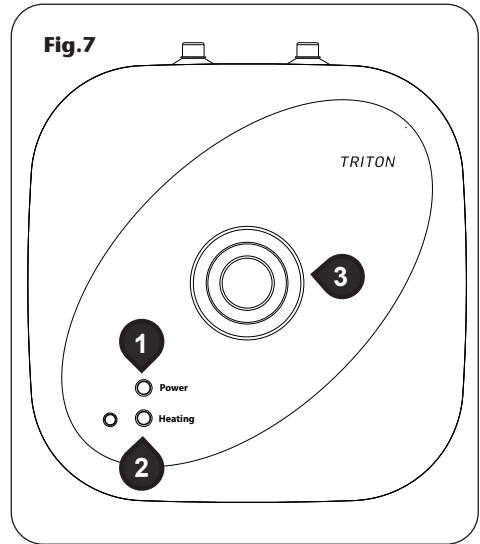

	5 litre	10 litre	15 litre
Minimum temperature setting	Approximately 25°C		
ECO temperature setting	Approximately 60°C		
Maximum temperature setting	Approximately 75°C		
*Heating time from 8°C to maximum	16 minutes	24 minutes	35 minutes

*Heating times for guidance only

MAINTENANCE

Pressure Relief Valve (PRV): The PRV protects the water heater from excessive pressure. For safe operation the PRV must be cleaned and inspected by a suitably competent person to check for normal functionality. The valve must not be obstructed, and for regions with hard water it must be descaled as necessary.

Sacrificial Anode: The magnesium anode has been designed to protect the water tank from corrosion and will degrade over time.

Triton recommend an annual inspection to keep your water heater working correctly - this inspection must be carried out by a suitably competent person.

Replacement parts are available from Triton Customer Experience - see contact details on page 17.

UNVENTED STORED WATER HEATER

IMPORTANT: Switch off the electricity supply and remove the circuit fuse before attempting any fault finding inside the unit.

All repairs/corrective actions should be carried out by a suitably qualified person.

PROBLEM	POSSIBLE CAUSE	ACTION
Pressure relief valve constantly dripping.	Mains pressure is above 6 bar.	A pressure reducing valve must be fitted.
Very hot water all the time.	Thermostat has failed.	Fit new component.
Dripping while heating.	Isolating valve has been fitted within the distance required for expansion.	Correct installation.
	Expansion vessel charge may have failed.	Check charge and correct.
No hot water.	The thermostat is faulty.	Fit new component.
	Thermal cut-out has operated.	
	The heating element has failed.	
No water.	Mains water supply turned off.	Turn on mains water supply.
	Debris causing a blockage.	Clear blockage.
	Valve incorrectly fitted.	Correct installation.
Metallic deposit in the water.	Anode corroded.	Check date for annual review.

To purchase a genuine Triton spare part for your product, please visit **www.tritonshowers.co.uk/spares**

for product codes and prices.

Alternatively please call our

Customer Experience team on

024 7637 2222 to order direct.

Please have your model name available.

WEEE Directive – Policy Statement

As a producer and a supplier of electric showers, Triton Showers is committed to the protection of the environment via our own environmental policy and compliance with the **WEEE directive**.

Triton Showers is fully registered with the Environment Agency under the following schemes:

Repic: Producer Takeback Scheme (PTS) registration number WEE/EJ3466QV

Valpak: Distributer Takeback Scheme (DTS) registration number DTS-501317-1

All our electric products are labelled accordingly with the crossed out wheeled bin symbol. This indicates, for disposal purposes at end of life, that these products must be taken to recognised collection points, such as local authority sites/local recycling centres; this will be free of any charges. **Do not return to Triton Showers.**



www.divapor.com

www.divapor.com

UK SERVICE POLICY

In the event of a product fault or complaint occurring, the following procedure should be followed:

DO NOT REMOVE THE PRODUCT

1. Telephone Customer Experience on **024 7637 2222** having available your details including post code, the model number and power rating of the product, together with the date of purchase and, where applicable, details of the particular fault.
2. If required, the Customer Experience Advisor will arrange for a qualified engineer to call.
3. All products attended to by a Triton service engineer must be installed in full accordance with the Triton installation guide applicable to the product. (Every product pack contains an installation guide, however, they can also be downloaded free at www.tritonshowers.co.uk).
4. Our engineer will require local parking and if a permit is required, this must be available to the engineer on arrival at the call.
5. If loft access is required for isolation or to complete a repair, the loft must have a fixed access ladder and be boarded, with appropriate lighting from the access point to and around the repair area.
6. It is essential that you or an appointed representative (who must be over 18 years of age) is present for the duration of the service engineer's visit. If the product is in guarantee you must produce proof of purchase.
7. Where a call under the terms of guarantee has been booked and the failure is not product related (i.e. scaling and furring, incorrect water pressure, pressure relief device operation or electrical/plumbing installation fault) a charge will be made. A charge will also be issued if nobody is at the property when the service engineer calls or adequate parking/permit is not available.
8. If the product is no longer covered by the guarantee an up-front fixed fee will be charged before the site visit.
9. Your receipt must be retained as proof of purchase. Should proof of purchase not be available on an 'in-guarantee' call, or should the service engineer find that the product is no longer under guarantee, the engineer will charge the same fixed price and will request payment prior to departing. If payment is not made on the day an administration charge will be added to the fixed charge.
10. If a debt is outstanding from a previous visit, or from any other Triton purchase, Triton reserves the right to withhold service until the debt has been settled.
11. Triton takes the health, safety and wellbeing of its employees very seriously and expects customers to treat all staff members with respect. Should any employee feel threatened or receive abuse, either verbally or physically, Triton reserves the right to withhold service.

Replacement Parts Policy

In line with AMDEA guidelines, Triton retains functional spares for as long as there is a market for them and in most cases, well beyond. Due to the vast array of product types, the life cycle of products can vary and therefore so can the length of time parts can be supplied. Spare parts can be ordered via our online spare parts store or by telephoning our Triton Customer Experience team on **024 7637 2222**. Payment should be made by credit / debit card (excluding American Express or Diners Card). Payment can also be made by pre-payment of a pro-forma invoice, by cheque or postal order.

Telephone orders are based on information given during the call. Before contacting Triton, please verify your requirements using the Information contained in the user guide. Triton cannot accept liability for incorrect part identification.

Triton Showers
Triton Road
Nuneaton
Warwickshire, CV11 4NR

Triton is a division of Norcros Group (Holdings) Limited

Triton reserve the right to change product specification without prior notice. E&OE. © TRITON SHOWERS 2023

TRITON UK STANDARD GUARANTEE

This guarantee applies only to products installed within the United Kingdom and does not apply to products used commercially. This guarantee does not affect your statutory rights.

With the exception of accessories, Triton guarantee the product against all manufacturing defects for a period of **2 years** (for domestic or light commercial use only) from the date of purchase, provided that it has been installed by a competent person in full accordance with the fitting instructions.

All accessories such as shower heads, hoses and riser rails carry a **1 year** parts only guarantee against manufacturing defects.

Any part found to be defective during this guarantee period we undertake to repair or replace at our option without charge, so long as it has been properly maintained and operated in accordance with the operating instructions and has not been subject to misuse or damage. This product must not be taken apart, modified or repaired except by a person authorised by Triton.

What is not covered:

1. Breakdown due to:
 - a) wilful act or neglect;
 - b) any malfunction resulting from the incorrect use or quality of electricity, gas or water or incorrect setting of controls;
 - c) failure to install in accordance with this installation guide.
2. Claims for missing parts once the product has been installed.
3. Repair costs for damage caused by foreign objects or substances.
4. Total loss of the product due to non-availability of parts.
5. Compensation for loss of use of the product or consequential loss of any kind.
6. Call out charges due to an abortive visit or where no fault has been found with the appliance.
7. The cost of repair or replacement of isolating switches, electrical cable, fuses and/or circuit breakers or any other accessories installed at the same time. Replacement of the Pressure Relief Device that only activates when the shower outlet is blocked is also excluded.
8. The cost of routine maintenance, adjustments, overhaul modifications or loss or damage arising therefrom, including the cost of repairing damage, breakdown, malfunction caused by corrosion, furring, frost or exposure to freezing conditions.
9. Call out charges where the water supply cannot be isolated, this includes consequential losses arising from unserviceable supply valves, or inaccessible product or valves located in a loft space without suitable access.

For the latest Terms & Conditions please see:

www.tritonshowers.co.uk/terms

PLEASE NOTE PRODUCT REGISTRATION IS ONLY AVAILABLE TO UNITS PURCHASED & INSTALLED IN THE UK

Customer Experience: 024 7637 2222

Trade Installer Hotline: 024 7637 8344

www.tritonshowers.co.uk

E-mail: serviceenquiries@tritonshowers.co.uk

E-mail: technical@tritonshowers.co.uk