

HERITAGE[®]

BATHROOMS

Installation Instructions
and User Guide

Diveter Kit and Rigid Riser

Models covered: STC10, STC11,
STC12, STC14, STC17 & STAI7

Please keep this booklet for future
reference.

Installer, when you have read these
instructions please ensure you leave
them with the user.

Important Safety Information

- Please read these instructions thoroughly and retain for future use.
- All products manufactured and supplied by Heritage are safe provided they are installed, used correctly and receive regular maintenance in accordance with these instructions.
- **If you are in any doubt about your ability to install this product safely you must employ the services of an experienced qualified tradesman.**
- Remove all packaging and check there are no missing or damaged parts.
- Before starting any installation please consider the following:
 - Before drilling into walls, check that there are no hidden electrical wires, cables or water supply pipes. This can be checked with the aid of an electronic detector.
 - If power tools are used do not forget to:
 - Wear eye protection
 - Unplug equipment after use
- This product must not be modified in any way as this will invalidate the guarantee.



Installation - Diverter

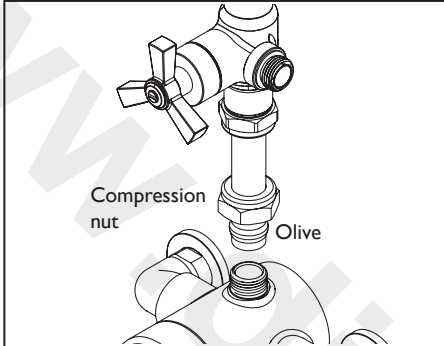

1. Push the short connecting tube into the top outlet on the shower valve (not supplied) ensuring the nut and olive are fitted to the connecting tube. Tighten the compression nut fully using a suitable spanner.

Important: If using this product on a low pressure system (0.1-0.2bar) we recommend the NRV in the diverter to be removed to ensure maximum flow.

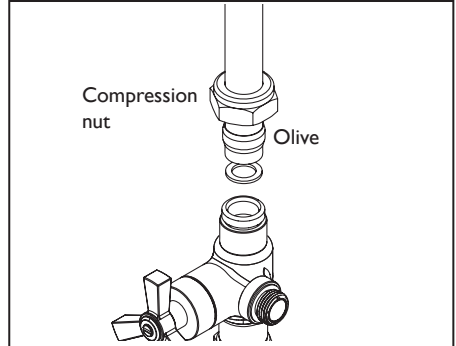

2. Fit the Rigid riser to the diverter valve. Tighten the compression nut fully using a suitable spanner to ensure a water tight seal.

For full rigid riser Installation please refer to the Installation Instructions supplied with the rigid riser.

Operation

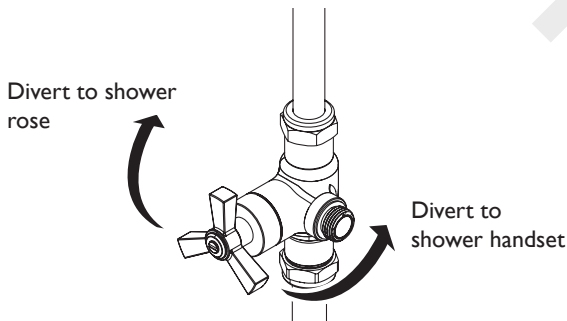

Installation - Rigid Riser

1

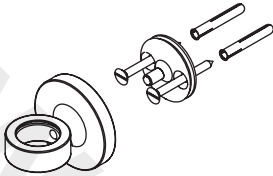

Position the fixing brackets equally apart against the wall. Mark the position and remove from the wall. Drill suitable holes and insert the wall plugs. Secure the brackets to the wall using the fixings supplied.

2

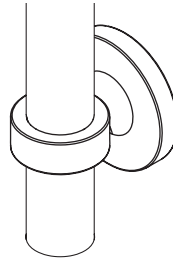

Slide the rigid riser rail through both wall brackets.

3

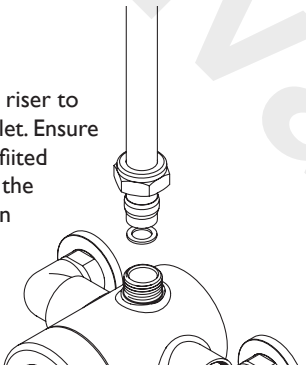

Fit the rigid riser to the top outlet. Ensure the olive is fitted and tighten the compression nut fully.

4

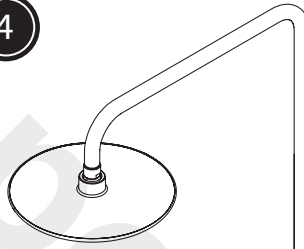

Screw the shower rose onto the arm. Ensure the sealing washer is used between the connections.

Guarantee



When you buy a Heritage product, you can be confident that it not only features a beautiful design, distinctive, classic design, but that it has also been made to the very highest quality standards.

In the unlikely event that you find a fault with our products, we offer solid guarantees and an attentive aftercare service to ensure that the problem is dealt with quickly and easily.

*Labour is provided by an approved engineer or appointed representative. The guarantee only applies to products with a manufacturing fault. There will be a call out charge for any incidents where no fault has been found with the product, or if the issue is due to poor installation or maintenance.

Guarantee Terms and Conditions

This guarantee is in addition to your statutory and other legal rights and is subject to the following conditions:

- The product was purchased within the United Kingdom or Republic of Ireland.
- The guarantee applies solely to the original purchaser with proof of purchase.
- The installation must allow ready access to all products for the purpose of inspection, maintenance or replacement.

- Repair under this guarantee does not extend the original expiry date. The guarantee on any replacement parts or product ends at the original expiry date.

- Any part found to be defective during the guarantee period will be replaced without charge, providing that the product has been installed in accordance with the instructions given in this guide

and used as the manufacturer intended. The guarantee does not cover:

- Damage or defects caused by:
 - General wear and tear (including special non-chrome finishes; components such as filters, seals, 'O' rings and washers)
 - Incorrect installation
 - Repair using non-Heritage parts
 - Accidental or wilful misuse
 - Corrosion and the use of inappropriate cleaning products
 - System debris including the build up of limescale (which can be controlled through regular servicing and maintenance)
- Compensation for loss of use of the product or consequential loss of any kind.

In the interests of continuous product improvement, Heritage reserves the right to alter product specifications without notice.

The Heritage Product Guarantee does not affect your statutory rights as a consumer.



Guarantee

• Need help?

If this product does not function correctly when first used, contact **Heritage Customer Service on 0844 701 8503** where our expert team of advisors will be able to offer you help and advice.

• Problems during the guarantee period
In the unlikely event that you encounter any problems with the product during the guarantee period, contact **Heritage Customer Service on 0844 701 8503** with your proof of purchase and we will work to resolve the problem quickly.

Heritage Customer Support

Heritage customers also benefit from the support of our comprehensive customer support package which offers:

Technical support hotline

Tel: 0844 701 8503 with access to fully trained advisers who can offer installation advice, talk you through quick maintenance checks, or recommend the best course of action to fix any problems with a product.

Spare parts

We hold thousands of spares and we keep them for discontinued products for over seven years. Spares can easily be ordered online at www.heritagebathrooms.com and are dispatched the same day.

Expert plumbing engineers

If we can't solve the problem over the 'phone or with a spare part, then we'll send out one of our engineers to take a look. Our engineers provide free support for products that are within guarantee, but are also available to service products that are out of guarantee for a small charge. For details, please call **Heritage Customer Service on 0844 701 8503**.



Notes



Please use this space to add any notes you or your installer may have regarding the plumbing system / installation of this product.

www.divapor.com





HERITAGE[®]

BATHROOMS

HERITAGE[®]

BATHROOMS

Birch Coppice Business Park
Dordon
Tamworth
Staffordshire
B78 1SG

Web: www.heritagebathrooms.com
Email: technical@heritagebathrooms.com
Tel: **0844 7018503**

Part Number: FI: Easton Range
Issue: D1

