

WWW.DIVARSLITY.COM

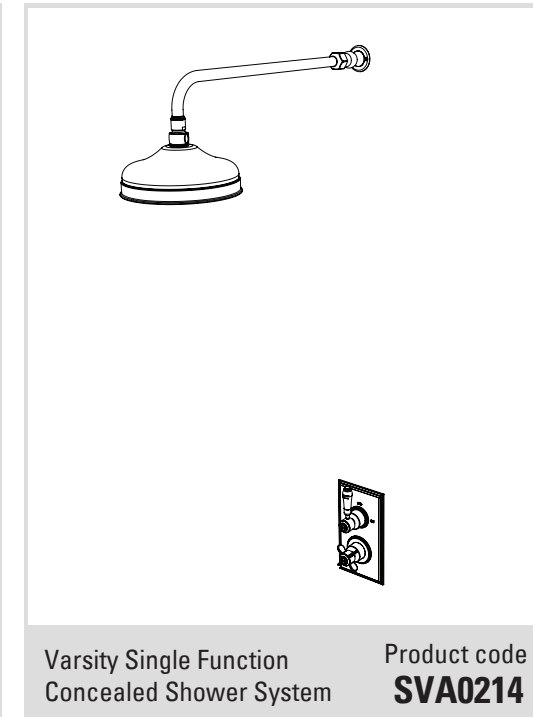

Varsity Concealed Shower System

Installation & aftercare instructions

Please retain for future reference

Introduction

Your exposed shower valve is a thermostatic mixer which incorporates a thermo-regulating cartridge to assure users of consistent showering temperatures. The valve has been designed & manufactured to comply with BS EN 1111:1999.

This valve complies with the requirements of the above regulations and installation should be carried out in strict compliance with them.

Operating Conditions of Use

Before installation the operating conditions of use must be checked. The table below contains details of the necessary conditions of operation. This valve is suitable for use with the following systems

- Gravity fed Hot & Cold (balanced pressures)
- Gravity fed Hot & mains Cold (balanced pressures)
- Unvented systems
- Gas combination boiler
- Pumped system

Note: On gravity systems the minimum Vertical distance (drop) from the underside of the cold water storage tank to the shower valve must be 3 metres for single function systems and 5 metres for dual function systems. If water supply is fed by gravity then supply pressure should be verified to ensure the conditions of use are appropriate for the valve

Maximum Static Pressure - BAR	10
Flow Pressure, Hot & Cold - BAR	0.3 to 5
Hot Supply Temperature - °C	55 to 65
Cold Supply Temperature - °C	Equal to or less than 25°C

Recommended outlet temperatures

The BuildCert TMV scheme recommends the following set maximum mixed water outlet temperatures for use in all premises:

41°C for showers;

The mixed water temperatures must never exceed 46°C.

The maximum mixed water temperature can be 2°C above the recommended maximum set outlet temperatures.

Note: 46°C is the maximum mixed water temperature from the bath tap. The maximum temperature takes account of the allowable temperature tolerances inherent in thermostatic mixing valves and temperature losses in metal baths. It is not a safe bathing temperature for adults or children.

The British Burns Association recommends 37 to 37.5°C as a comfortable bathing temperature for children. In premises covered by the Care Standards Act 2000, the maximum mixed water outlet temperature is 43°C.

The thermostatic mixing valve will be installed in such a position that maintenance of the TMV and its valves and the commissioning and testing of the TMV can be undertaken.

The fitting of strainers is recommended as close as is practicable to the water supply inlets of the thermostatic mixing valve.

Valve Installation Guidelines and Compliance

The valve must be installed so that it is readily accessible for commissioning and maintenance. The valve must be installed with isolation valves on both the hot and cold water systems as close as possible to the valve; so as to allow the valve to be commissioned and tested correctly. The valve is fitted with integral check valve cartridges which command the water supply, therefore the thermostatic valve is protected against cross-flow due to unbalanced line pressures as required by the Water Supply (Water Fittings) Regulations 1999.

Most problems associated with the operation of thermostatic shower valves are caused by debris in the new pipe work getting into the thermostat. These problems are easily avoided by thoroughly flushing the pipe work BEFORE the shower valve is fitted

General Dimension

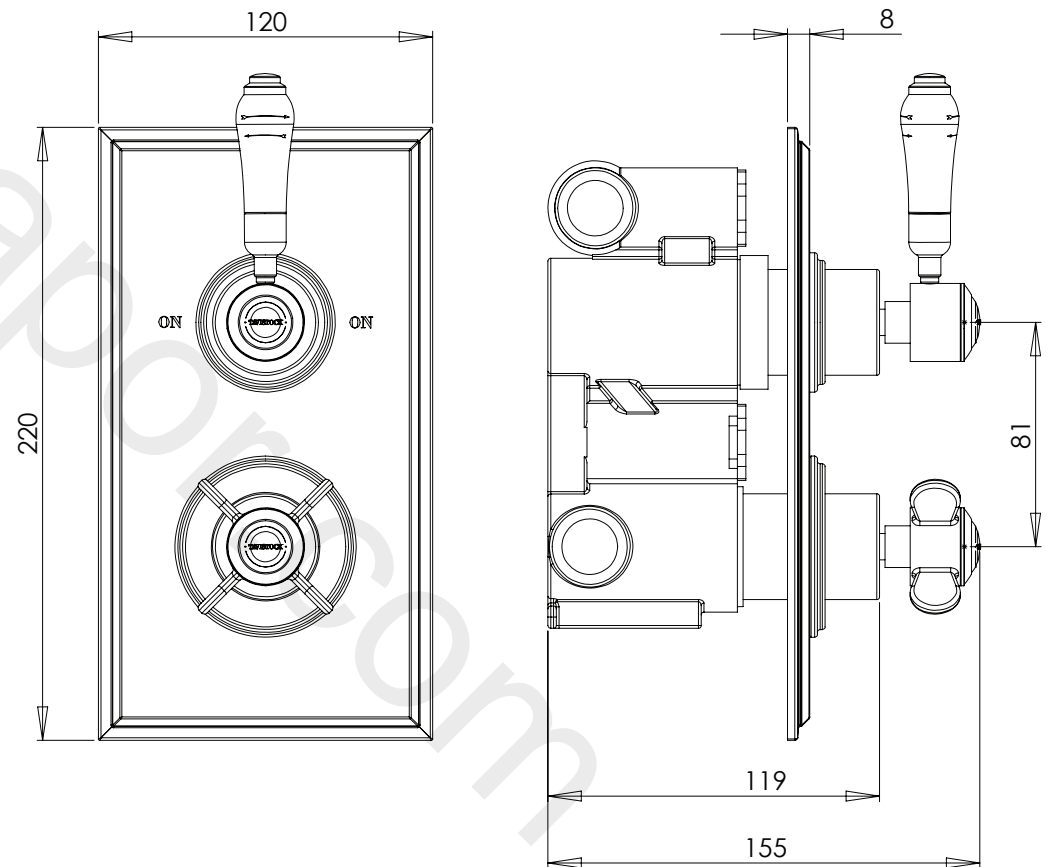

Mounting the Shower Valve

1. Determine the mounting position for the shower valve. Pipework must be flushed out before assembly of the valve.
2. Prepare the recess in the wall in which to mount the valve. Ensure the cover plate will hide the cut recess after installation of the valve.

The depth of the recess for the valve should be: MIN 85mm, MAX 95mm.

3. Mount the valve in the recess using the fixing lugs and supplied fixing screws to secure (see diagram below). Ensure that the hot inlet of the valve is on the left and the cold on the right (see fig 1)
4. When the valve is securely mounted into the wall make the plumbing connections using PTFE tape. Inlets and outlets for the single function valve are tapped 3/4" BSP, The dual function valves includes tapped 1/2" BSP. **IMPORTANT:** Do not use tapered threaded adaptors, this may damage the valve body.
5. Connect the water outlet to the valve primary outlets connection e.g. shower handset via wall elbow and shower head.
6. Turn on the water supply and test all pipe work for leaks.

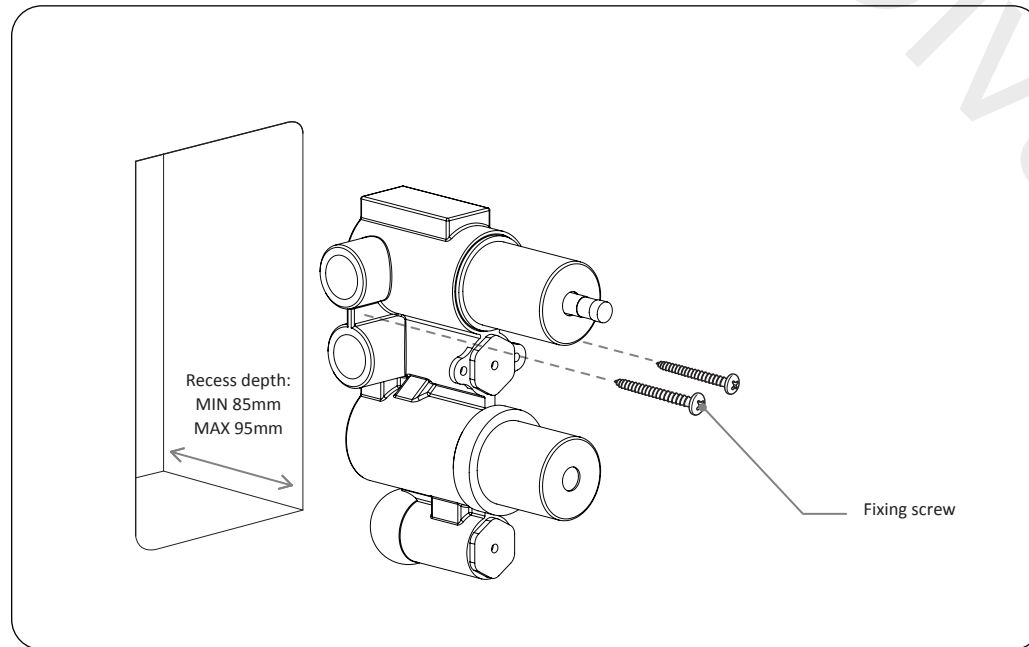

Maintenance

We advise that the valves, check valves and filters be regularly serviced particularly in hard water areas. The check valves along with the filters are contained in the retaining nut. The water supplies must be isolated remotely from the valve before removal.

Valves should be tested against the original set temperature results once a year. When testing is due the following performance checks shall be carried out.

1. Measure the mixed water temperature at the outlet.
2. Carry out the cold fail-safe shut off test by isolating the cold water supply to the TMV, wait for 5 seconds if water is still flowing check that the temperature is below 46 degrees C.
3. If there is no significant change to the set outlet temperature (+/- 2°C or less change from the original setting) and the fail safe shut off is functioning, then the valve is working correctly and no further service work is required.

If further maintenance should be required contact Roper Rhodes for details. Please see contact details on the back page of this document.

10 Year Guarantee

We have complete confidence in this Tavistock product and as such it is offered with a 10-year guarantee against defects in manufacture. This valve must be fitted by a competent installer. If in doubt seek advice from a qualified professional. The guarantee requires that this product be used in the manner for which it was intended and that it is installed & maintained in accordance with the fitting instructions and local water bylaws. The guarantee covers products in domestic use only. Always ensure this product is fully tested before concealing valves into the wall. On installation ensure that the valve and valve inlet threads can be removed or serviced in accordance with UK regulations. The guarantee is invalidated should the valve be damaged by water borne debris. Make sure that supply pipes are clear of any debris prior to installation, this is particularly important on new plumbing installations. In the unlikely event that this product should fail during the guarantee period we will either replace the faulty part or the complete unit as appropriate. This guarantee excludes normal wear and tear. This guarantee covers failure of the thermostatic cartridge within the first 2 years of purchase only. Replacement cartridges are available to purchase by contacting the Roper Rhodes Customer Service team. Failure to follow the terms outlined above will invalidate this guarantee. Proof of purchase will be required to validate any guarantee claims.

Operating

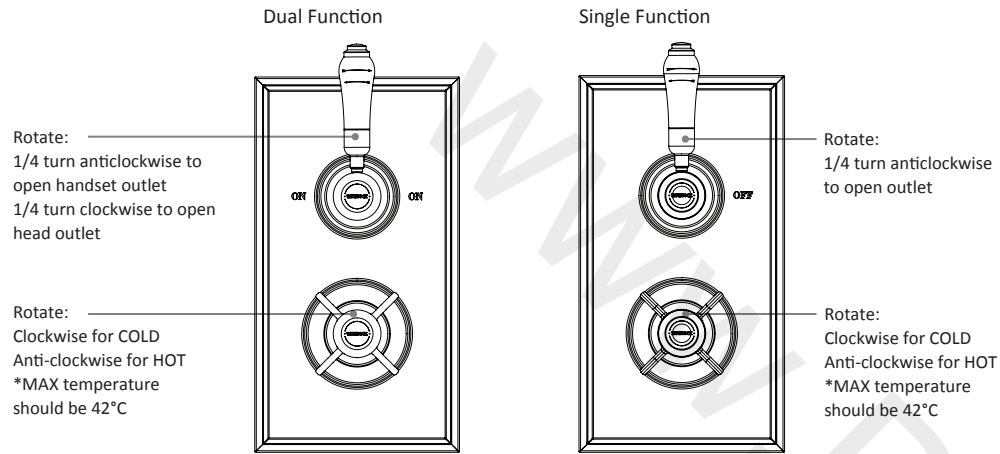

Maintenance

Problem	Solution
After installation shower only runs HOT or COLD and will not mix.	Check Hot & Cold supplies are plumbed the correct way round.
Shower will not run hot enough when first installed	Check temperature and of hot and cold entering the valve. Check for debris in the pipe work or valve inlets.
Cold water running back through the valve into the hot water system.	Check and clean the check valve cartridges and filters located under the check valves.

If you require further assistance beyond the guide below contact the help line on 01225 787 870

FIGURE 1

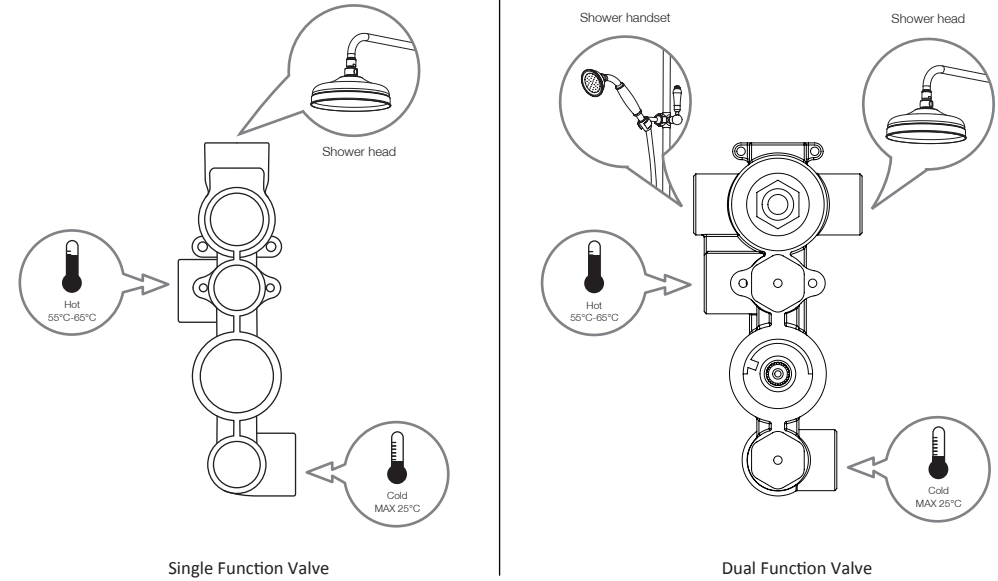
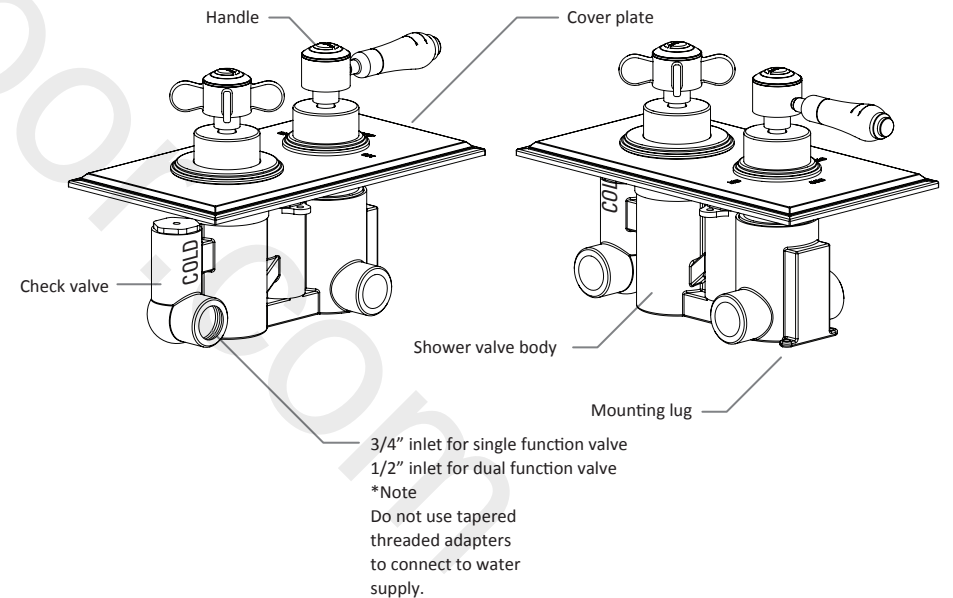
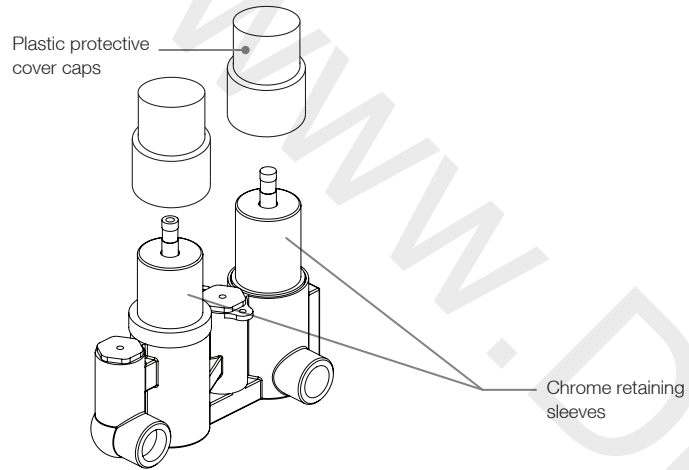

FIGURE 2



Assembly of Cover Plate

9. The valve is supplied with plastic protection covers. These can be left in place to protect the thermostat until assembly of the plate and handles and final commissioning of the valve is required. At this time, remove the protection cover whilst keeping the chrome retaining sleeve in place over the thermostat body.



10. Apply a small bead of silicone behind the front cover plate and slide over the body into position. Smooth off against the wall finish.

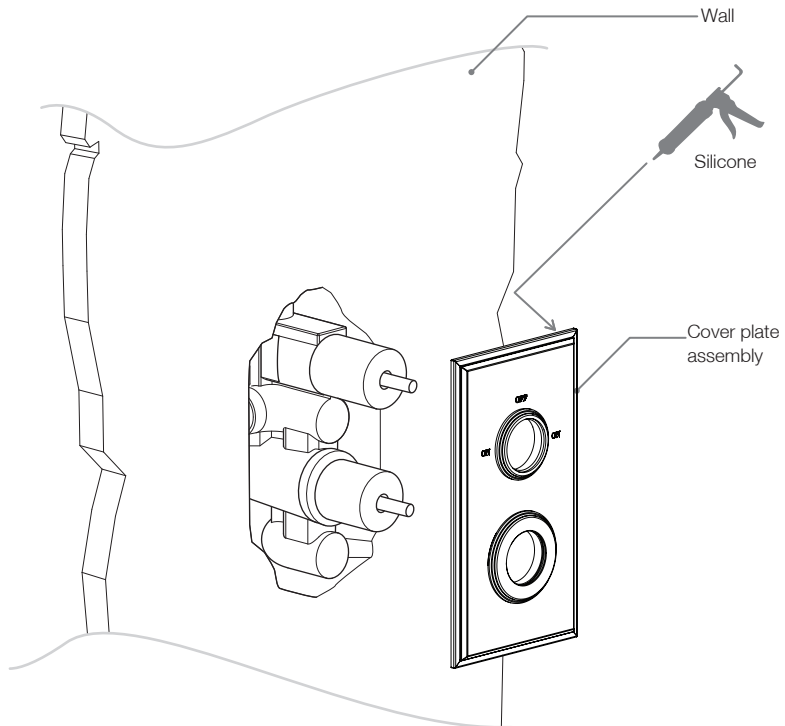

Installation of Handles

To fit the handles

1. Remove the screw cap from the front of the handle
2. Mount the handle onto the spindles
3. Using the fixing screw found inside the handle, screw the handle down tight onto the spindle.

To change the position of the indices

1. Remove the screw cap from the front of the handle
2. Unscrew the brass fixing ring that is found inside the screw cap, this will release the ceramic indices
3. Reposition the indices to the preferred location.
4. Screw the brass fixing ring back onto the ceramic indices being careful not to move the indices from the preferred location
5. Re-fit the handle

