

ASQUITHS

BATHROOMS OF TRANSFORMATION

BRASSWARE FITTING GUIDE



GENERAL FITTING GUIDE

THERMOSTATIC WALL MOUNTED BATH SHOWER MIXER & EXPOSED SHOWER VALVE

PRODUCT SHOWN WILL VARY
DEPENDING ON MODEL

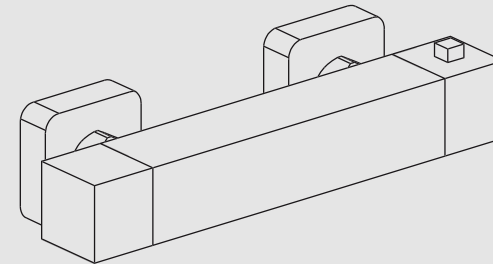
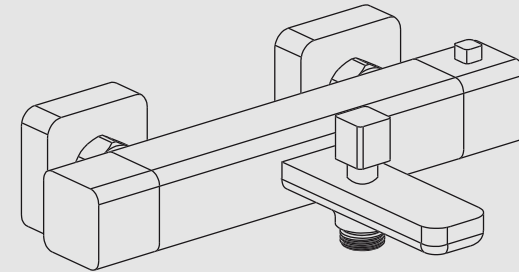

Important Information

This installation guide is for all types of thermostatic bar shower valves and thermostatic bar BSM's. All the valves are thermostatically controlled. See specific product technical data sheets which can be found on our website, just enter the relevant product code for full details.

Guarantee & Aftercare

When installing or using tools, extra care must be taken to avoid damaging the finish or fitting. To maintain the appearance, please ensure it is cleaned regularly using a clean soft damp cloth only. Abrasive cleaners or detergents must not be used as they may cause surface deterioration. The company provides a guarantee against faulty material or manufacture excluding serviceable parts, providing they have been installed, cared for and used in accordance with our instructions.

Water Supply Regulations

This product has been manufactured to comply with the appropriate BS EN Standards and to conform to Water Supply Regulations 1999.

Earth Bonding

Earth any new pipework satisfactorily (Seek expert advice if in doubt).

The company reserves the right to continually evolve its product lines without notification.

The company will not accept any liability regarding specification changes and their consequences unless previously quoted by the company in writing.

Safety

We recommend that this product is fitted by a fully qualified installer. The installation must comply with all current water regulations. Please note: This valve must be commissioned during installation to suit site conditions. In order for this product to operate as designed it must be installed and commissioned as stated in this manual. See **COMMISSIONING & SAFETY TEMPERATURE ADJUSTMENT**.

Technical Data

See specific product technical data sheets which can be found on our website, enter the relevant product code for full details.

Hot water supply temperature: 55 - 65 degrees.

Operation

To activate the flow of water, turn the flow control handle to the "on" position. Turn the temperature control handle anti-clockwise to increase the water temperature. To increase the temperature further you will need to press the override button and continue turning the handle. Turning the same handle clockwise will decrease the water temperature.

Installation Procedure

1. Prior to installation please ensure all the supply pipes have been flushed through to remove any debris and then ensure the water supply is turned off.
2. We strongly recommend the fitting of isolation valves to the inlet feeds for ease of future maintenance.
3. Ensure you have all the relevant tools before commencing the installation and take note of any specific markings on the product to make sure they are installed correctly.
4. Carefully assemble new fitting. Do **NOT** over-tighten as this may cause damage to the fitting.
5. Connect water supply to the inlet connector. The HOT supply should always be connected to the LH side when viewing the fitting from the front.
Please ensure you take note of any specific markings on the product to make sure they are installed correctly
6. Ensure fitting is in the 'on' position and turn on the water supply. Allow the tap to run for a few minutes to flush out any debris.
7. Check all water feed connections to ensure there are no leaks.
8. Check the assembled fit of the products to ensure there is no water ingress that may cause water damage after installation.

PLEASE REFER TO THE TEMPERATURE ADJUSTMENT INSTRUCTION WHEN COMMISSIONING THE SHOWER.

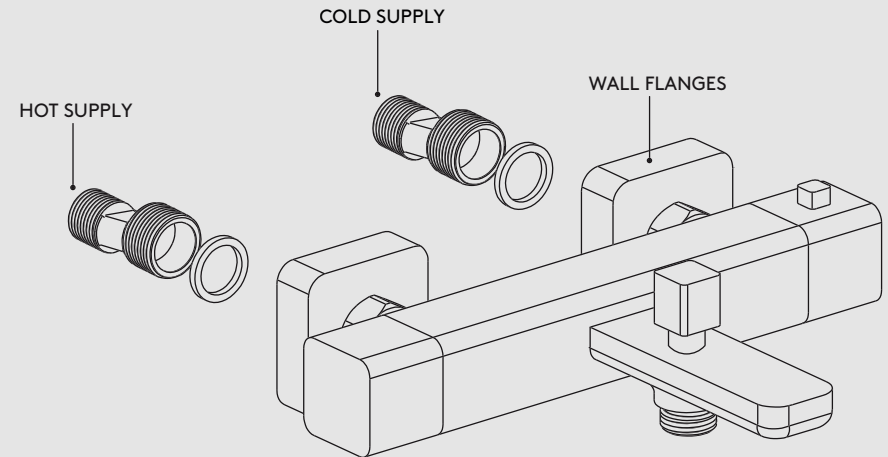

Commissioning & Safety Temperature Adjustment

The shower valve temperature is factory pre-set to a safe 38 degrees at the temperature handle safety stop point, but under certain site conditions, calibration may be required to achieve this safety set point, if required.

Please follow the procedure below to calibrate the shower to the 38 degrees safety stop point.

- Check - The hot water supply temperature **Must be 55 - 65 degrees**.
- Turn the flow control handle to the maximum flow.
- Turn the temperature handle anti-clockwise to the temperature safety stop point and check the temperature of the water from the outlet. If the water temperature is not achieving 38 degrees, please follow the procedure below.
- Remove the temperature handle and put to one side.
- The temperature cartridge stop lug and thermostatic cartridge spline will now be visible.
- Relocate the temperature handle onto the thermostatic cartridge spline by a few mm - enough to just engage with the thermostatic cartridge spline, but not so it comes into contact with the temperature cartridge stop lug.
- To **DECREASE** the water temperature turn the temperature handle clockwise by a few increments and allow the temperature to stabilise - measure the outlet water temperature. Repeat this process as necessary until 38° C is reached.
- To **INCREASE** the water temperature turn the temperature handle anti-clockwise by a few increments and allow the temperature to stabilise - measure the outlet water temperature. Repeat this process as necessary until 38° C degrees is reached.

- Re-fit the temperature handle - being careful not to further adjust the 38° C set point, carefully remove the temperature handle and relocate it back onto the thermostatic cartridge spindle, ensuring that the temperature handle override button pin is set against the thermostatic cartridge stop lug. This will stop the user accidentally setting the showering temperature beyond 38° C unless they use the override button.
- Re-secure the thermostatic handle in place.

Aftercare

Please take care not to damage the surface finish of the valve. The finish is polished chrome and can be easily marked. **Any misuse will invalidate your guarantee**

Fault Diagnosis

FAULT	POSSIBLE CAUSE	ACTION REQUIRED
1. The showering water temperature is too hot.	1.1 Temperature set point incorrectly commissioned.	1.1.1 Please see 'Commissioning & Safety Temperature Adjustment'.
2. The showering water temperature is too cold.	2.1 Temperature set point incorrectly commissioned.	2.1.1 Please see 'Commissioning & Safety Temperature Adjustment'.
	2.2 Hot water supply temperature not hot enough.	2.2.1 Check that the hot water temperature at a basin tap is acceptable, which should be around 55-60 degrees. If it isn't, make sure the heating appliance is adjusted to increase the hot supply temperature. 2.2.2 Make sure the heating appliance has sufficient hot water storage capacity.
3. Water is not mixing correctly, or shower temperature is varying.	3.1 Hot and cold water supplies are plumbed to the wrong side of the valve body.	3.1.1 Re-plumb the shower valve with the hot and cold feed feeding to the correct inlet ports of the valve.
	3.2 Combi-boiler is cycling	3.2.1 Contact your boiler service engineer
4. Low or no water flow from shower.	4.1 Operating conditions are incorrect.	4.1.1 See Technical data for correct operating pressures.
	4.2 Water supplies have been cut off.	4.2.1 Check other water outlets elsewhere in the house, and contact water authority if necessary.
	4.3 Shower unit or outlet may be blocked (handset, shower head etc).	4.3.1 Check if shower outlet is blocked. Clean as necessary.
	4.4 Valve anti-scald has activated due to operating conditions.	4.4.1 See Technical data for correct operating pressures and inlet water supply temperatures.
	4.5 Possible blockage in the system.	4.5.1 Check & clean any filters as necessary.
4.5.2 Supply pipe work may be blocked. Consult a qualified installer.		
4.5.3 Make sure any in line service isolator valves are in the fully open position.		
5. Leak when shower valve in the "off" position.	5.1 Check that the leak is from the shower valve and not residual of water in the shower head/handset.	5.1.1 Remove the shower head/handset from it's feed to see if any water is dripping from the flexible hose or shower arm. If this is not leaking you are experiencing residual water in the shower fitting which is not a fault.
		5.1.2 If the leak is from the shower valve, a new flow control cartridge is required.

Aftercare

Please take care not to damage the surface finish of the valve. The finish is polished chrome and can be easily marked. **Any misuse will invalidate your guarantee**



ASQUITHSBATHROOMS.COM