

HERITAGE[®]

BATHROOMS

Dawlish Tap Range Installation Instructions and User Guide

Models covered:

TDCC04 / TDCG04	Basin Mixer
TDCC05 / TDCG05	Bidet Mixer
TDCC06 / TDCG06	3 Hole Basin Mixer

Please keep this booklet for future reference.

Installer: when you have read these instructions please ensure you leave them with the user.

Contents

When you buy a Heritage product, you can be confident that it not only features a beautiful, distinctive, classic design, but that it has also been made to the very highest quality standards. To ensure that it works to its full potential, it needs to be fitted correctly.

These fitting instructions have been created to give you all of the information you need and, if you need any further help, please do not hesitate to give us a call on **0844 701 8503**.

Important Safety Information	02
General Specifications	02
Dimensions	03
Installation	04-07
Basin / Bidet Mixer	04-05
3 Hole Basin Mixer	06-07
Maintenance	08-09
Map Of Hard Water Regions	10
Troubleshooting	11
Guarantee	12-13
Notes	14





Safety Note

- Please read these instructions & retain for future use. All products manufactured & supplied by Heritage are safe, provided they are installed correctly, used correctly, and receive regular maintenance in accordance with these instructions.
- **If you are in any doubt about your ability to install this product safely you must employ the services of an experienced, qualified plumber.**



Before starting any installation project please consider the following:

- Prior to drilling into walls, check there are no hidden electrical wires or cables or water supply pipes with the aid of an electrical detector.
- If you use power tools do not forget:
 - Wear eye protection.
 - Unplug equipment after use.
- This product must not be modified in any way as this will invalidate the guarantee.
- These fittings need to be installed in accordance with and meet the requirements of the Water Supply (Water Fittings) Regulations 1999 and Scottish Byelaws 2004.

General Specifications

Operating pressure range (bar)	Min	Max
Bidet Mixer	0.1	5.0
Basin Mixer	0.1	5.0
3 Hole Basin Mixer	0.2	5.0

Maximum Static Pressure – 10.0 bar

NOTE:- Nominally equal (balanced) inlet supply pressures are recommended for optimum Performance of mixer taps.

Designed to comply with BS EN 200 for single taps / combination taps for water systems of type 1 and 2 general technical specifications; and to be used within systems designed to BS 6700.

BS 6700 recommends the temperature of stored water should never exceed 65°C. A stored water temperature of 60°C is considered sufficient to meet all nominal requirements and will minimise the build up of lime scale in hard water areas.



Dimensions

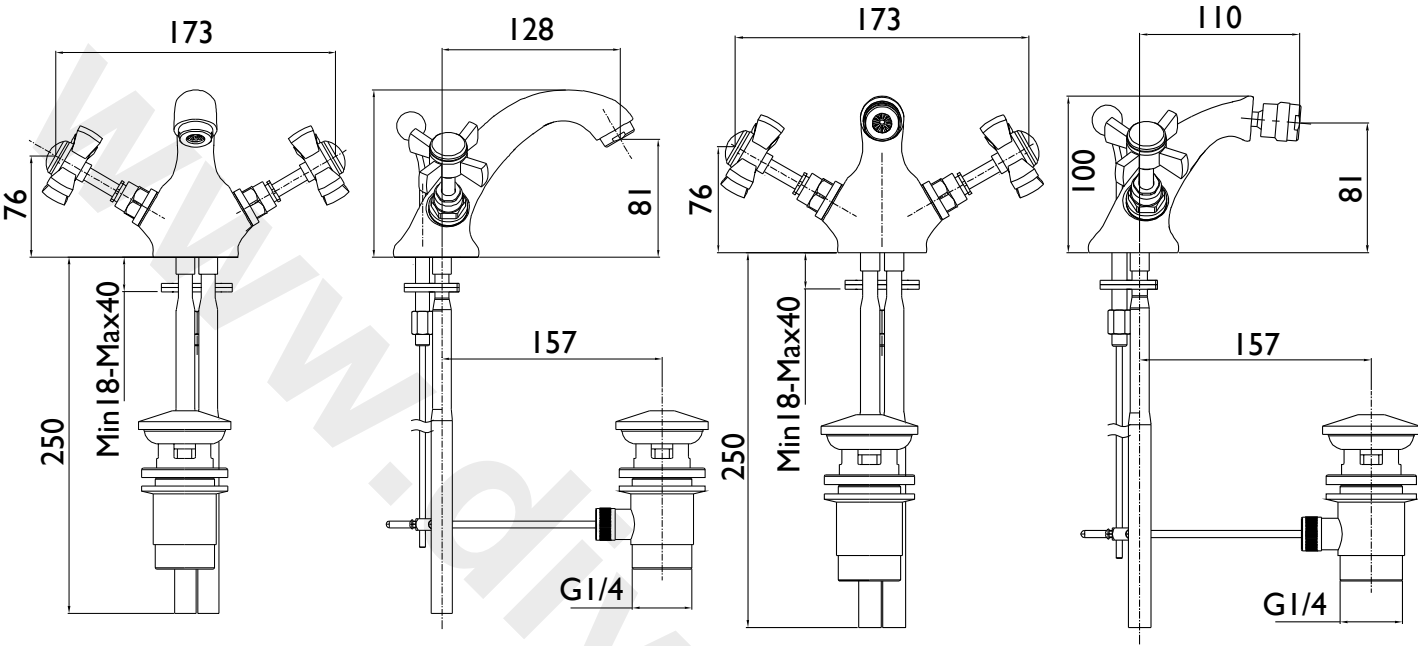

Basin Mixer (TDCC04 / TDCG04)

Bidet Mixer (TDCC05 / TDCG05)

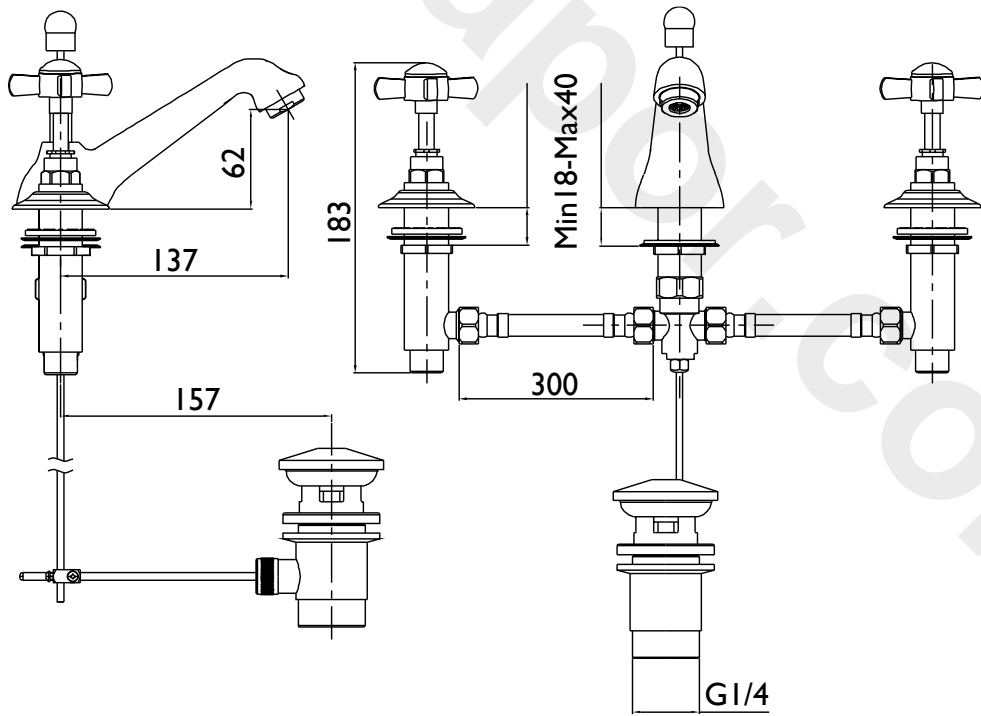

3 Hole Basin Mixer (TDCC06 / TDCG06)





Installation

Basin and Bidet Mixer

1. Identify all components are present prior to starting installation.
2. Fit the mixer body to the basin/bidet using the 'C' plate fixing kit. The full rubber washer (12) goes between the fitting and the basin/bidet, and the 'C' shaped rubber (13) and metal washer (14) on the underside of the basin/bidet, to be secured by the threaded tail and backnut (15).
3. Fit the connecting pipes (19) to the fitting and connect the hot and cold supplies. **DO NOT OVERTIGHTEN**. Soft copper tails can be carefully bent and cut to length to meet supply pipes.
4. Fit the pop-up waste, with the flat washer below and the shaped washer above the basin/bidet. It is recommended that a silicon sealant be applied to both sealing faces of washers. The plug height can be set by adjusting the waste rod (17) and operating rod (10) connecting bracket (18), and the screw in the base of the plug. If the plug will not stay closed, the friction of the pop up mechanism can be increased by tightening the nut.
5. Fully open both valves, letting them run for a few minutes to flush out the system and check all joints and connections for leaks.

1.	Indice	x2	11.	Mixer Body	x1
2.	Grub Screw	x2	12.	Washer	x1
3.	Metal Washer	x2	13.	C-Shaped Rubber Plate	x1
4.	Handle	x2	14.	C-Shaped Metal Plate	x1
5.	Shroud	x2	15.	Threaded Tail & Backnut	x1
6.	Washer	x2	16.	Waste Assembly	x1
7.	Valve	x2	17.	Horizontal Waste Rod	x1
8.	Anti-Splash Assembly	x1	18.	Pop Up Link	x1
9.	Pop Up Knob	x1	19.	Connecting Pipes	x2
10.	Pop-Up Rod	x1			



Installation Cont.

Basin and Bidet Mixer

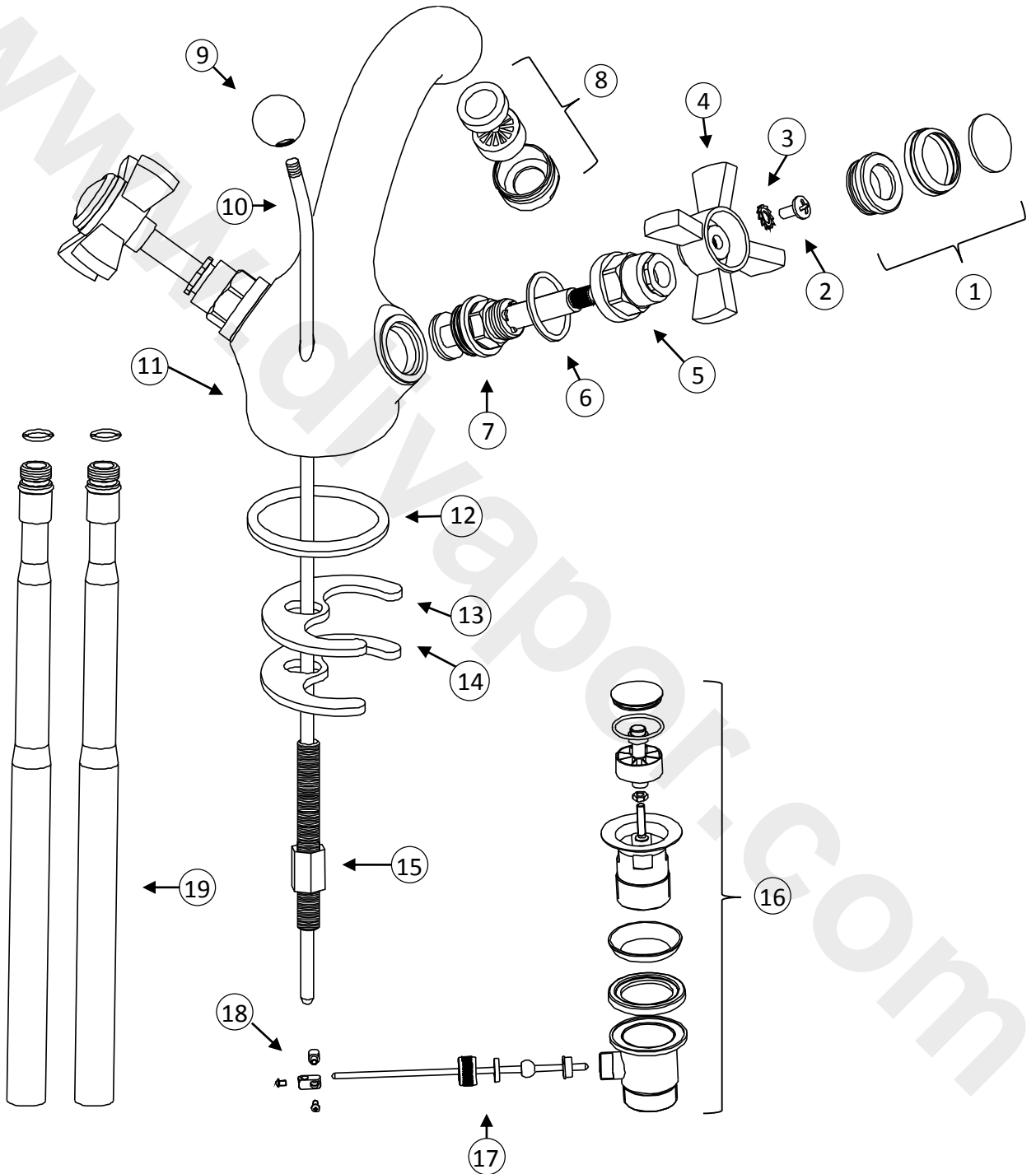



Installation Cont

1. Identify all components and check for completeness particularly before arranging fitting.
2. Disassemble the two side bodies and remove the T joint assembly, (20) from the mixer body (03). Remove spout backnut (19) & washer (18) before fitting the spout to the basin. Re-apply backnut and washer to secure in to place.
3. Re-connect the 'T' joint and fit the two connecting pipes (17). Place the backnut (15) and washer (14) on to both side bodies and secure into place by screwing the shroud (12) top side of the basin/bidet. Ensure that the washer (13) is also in place and connect the remaining handle assembly. Tighten the backnut below to secure into place.
4. Fit the upper part of the pop up waste assembly (23) with washer above the basin. Fit the lower part of the waste assembly underneath the basin It is recommended that a silicon sealant be applied to both sealing faces of the two washers that sit against the basin. Ensure the threaded section on the body is facing the wall at the rear, in order to accommodate the waste rod (22).
5. Connect the waste arm (22) to the underside of the waste assembly and attach the pop-up link (21). Proceed to feed the operating knob (2) through the mixer body and 'T' joint and attach to the pup up link (21).

1.	Pop-Up Knob	x1	13.	Shroud Seal	x3
2.	Pop-Up Operating Rod	x1	14.	Washer	x3
3.	Mixer Body	x1	15.	Backnut	x3
4.	Anti-Splash Assembly	x1	16.	Side Body	x2
5.	Indice	x2	17.	Connecting Pipe	x2
6.	Screw	x2	18.	Spout Washer	x1
7.	Metal Washer	x2	19.	Spout Backnut	x1
8.	Handle	x2	20.	'T' joint	x1
9.	Shroud	x2	21.	Pop-Up Link	x1
10.	Washer	x2	22.	Waste Rod	x1
11.	Valve	x2	23.	Waste Assembly	x1
12.	Base Shroud	x2			



Installation Cont

3 Hole Basin Mixer

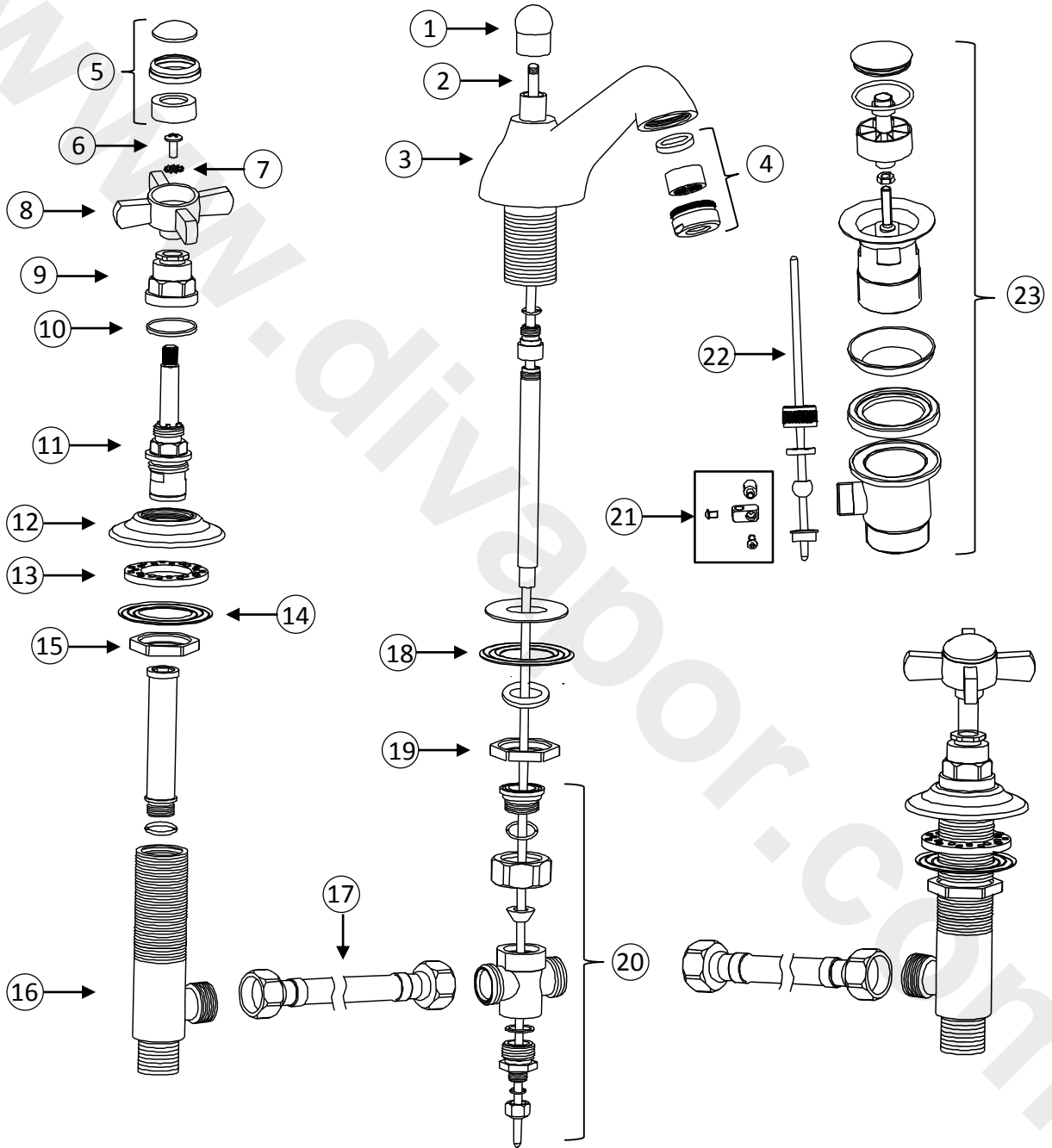



Installation Cont.

3 Hole Basin Mixer & 3 Hole Bath Filler

6. The height of the plug can be adjusted by lengthening or shortening the screw on the under side of the plug & locked by the nut on the screw. If the plug will not stay closed the friction of the pop up mechanism can be increased by tightening the nut (9).
7. Fully open both valves, letting them run for a few minutes to check all joints & connections for leaks.

Maintenance

General Cleaning

Your fitting has a high quality finish and should be treated with care to preserve the visible surfaces. All finishes will wear if not cleaned correctly. The only safe way to clean your product is to wipe with a soft damp cloth. Stains can be removed using washing up liquid. All bathroom cleaning products (powders and liquids) will damage the surface of your fitting, even the non-scratch cleaners.

Note: Never use abrasive detergents or disinfectants or those containing alcohol, hydrochloric acid or phosphoric acid.



Maintenance Cont.

Cleaning the Valves

If your fitting begins to leak the following should be carried out;

Isolate both hot and cold water supplies to the tap by either:

- Turning the water supply off at the mains stopcock or
- Turning off the isolation valves to the tap.

1. Remove the indice to reveal the concealed grub screw and metal washer and proceed to remove these using a suitable screw driver.
2. Remove the handle by pulling upwards/away from the shroud.
3. Unscrew the shroud and using a suitable spanner remove the valve concealed within. Be sure to retain the o-ring.
4. Lift out the valve and clean thoroughly. Be sure to check and clean out the seating within the tap body/assembly.
5. If necessary replace the valve.
6. Please visit www.heritagebathrooms.com in order to find spare parts for this product.
7. Place the valve into the tap body and tighten the valve fully using a suitable spanner.
8. Replace shroud and handle, ensuring to refit the grub screw.
9. Turn on water supply and check for leaks.
9. Contact our helpline should if problem persists.

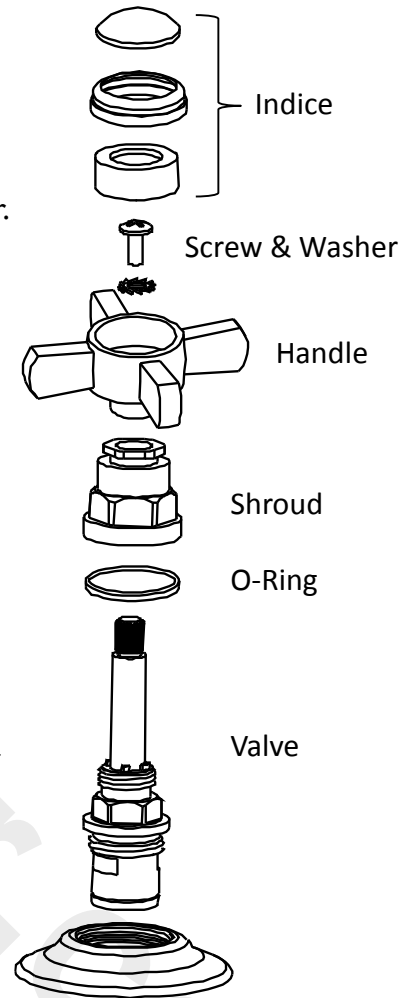



Map of Hard Water Regions



Soft to moderately soft
0 - 100mg/l as calcium carbonate equivalent



Slightly hard to moderately hard
100 - 200mg/l as calcium carbonate equivalent



Hard to very hard
Above 200mg/l as calcium carbonate equivalent

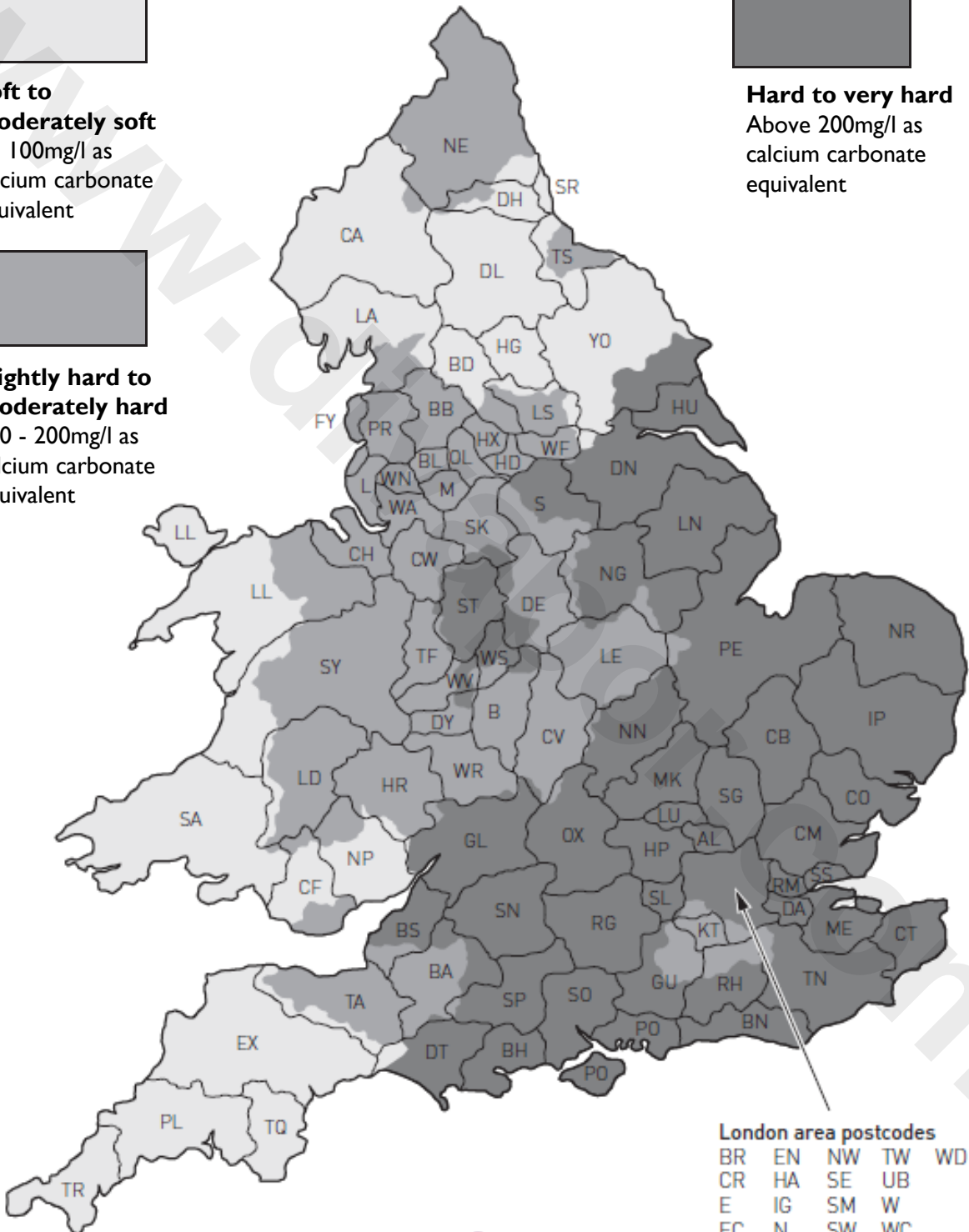

Troubleshooting

Symptom	Cause	Remedy
No flow or poor flow rate.	Partially closed stop or service valve in water supply pipework to the tap.	Open stop or service valve.
	Head of water is below the minimum distance required.	Refer to the Specification section for minimum pressures required.
	Possible airlock / blockage in supply pipework	Remove water supplies from the fitting and flush the system to remove any airlocks / debris.
	Cartridge not opening fully.	Service fitting. Refer to maintenance section on pages 08-09.
Water dripping for a few seconds after the tap has been turned off.	This is caused by 'capillary action' and residual water in the spout being siphoned out. This should only last for a couple of seconds.	
Constant dripping / leaking when the tap is not in use.	Cartridge / Valve not fully shutting off.	Service fitting and replace cartridge. Refer to maintenance section on page 08-09.
Fitting does not turn on.	Water supplies not turned on.	Check that the water supplies to the fitting are turned on.
	Closed stop or service valve.	Open stop or service valve.
Water does not come out of the showerhead when using the bath shower mixer.	Diverter mechanism not fully open.	Turn the diverter mechanism into the appropriate position.
	Insufficient water pressure / header height.	Refer to the specification section for minimum pressures required.





Heritage Bathrooms Guarantee

When you buy a Heritage product, you can be confident that it not only features distinctive design, but that it has also been made to meet our rigorous quality standards.

We offer robust guarantees and an attentive aftercare service to ensure that if you do experience any issues, we can deal with a problem quickly, and effectively.

Please note that guarantees are only valid with proof of purchase.

Our guarantees are as follows:



2 Years on
Mirrors &
WC Seats



5 Years on
Bath Screens,
Furniture,
Shower Valves,
Taps, Wastes
& Accessories



Lifetime Guarantee
on Acrylic &
Cast Iron Baths
And Sanitaryware

Register now for additional peace of mind

Register your product with us now and, if you do have any queries after installation, we'll be able to quickly identify the product and give you the best advice. It also means that you won't have to keep your proof of purchase to validate your guarantee. To register, simply go online at www.heritagebathrooms.com/register

Guarantee Terms and Conditions

This guarantee is in addition to your statutory and other legal rights and is subject to the following conditions:

- The product was purchased within the United Kingdom or Republic of Ireland
- The product is used in domestic applications only
- The guarantee applies solely to the original purchaser with proof of purchase
- The installation must allow ready access to all products for the purpose of inspection, maintenance or replacement
- Repair under this guarantee does not extend the original expiry date. The guarantee on any replacement parts or product ends at the original expiry date

Any part found to be defective during the guarantee period will be replaced without charge, providing that the product has been installed in accordance with the instructions given in this guide and used as the manufacturer intended. If the product is no longer available, Heritage will endeavour to provide the nearest equivalent.



Heritage Bathrooms Guarantee Cont.

The guarantee does not cover:

- Damage or defects caused by
 - General wear and tear (including special non-chrome finishes; components such as filters, seals, 'O' rings and washers)
 - Incorrect installation
 - Repair using non-Heritage parts
 - Accidental or wilful misuse
 - Corrosion and the use of inappropriate cleaning products.
 - System debris including the build-up of limescale (which can be controlled through regular servicing and maintenance)
- Compensation for loss of use of the product or consequential loss of any kind.

In the interests of continuous product improvement, Heritage reserves the right to alter product specifications without notice.

Need help?

In the unlikely event that you encounter a problem with your Heritage product, you must, in the first instance, contact the retailer you purchased it from. They will advise as to whether it is due to a manufacturing fault or an installation fault. If the problem is due to a manufacturing fault, they will contact us to arrange a supply of a replacement product as soon as possible. To speak to a Heritage customer service advisor, please contact our technical helpline on **0844 701 8503**.





Notes

Please use this space to add any notes which you or your installer may have regarding the plumbing, installation and/or servicing of this product:

www.divapor.com





HERITAGE®
BATHROOMS

Heritage Bathrooms
Birch Coppice Business Park
Dordon
Tamworth
B78 1SG

Website: www.heritagebathrooms.com

Telephone: 0844 701 8503

Email: technical@heritagebathrooms.com

HFI (DAWLISH BAS/BID) REV. D1

