

# HERITAGE<sup>®</sup>

## BATHROOMS

### Hemsby Wall Mounted Tap Range Installation Instructions and User Guide

**Models covered:**

- THPC10 3 Hole Wall Mounted Basin Mixer
- THPC11 3 Hole Wall Mounted Bath Filler

Please keep this booklet for future reference.

Installer: when you have read these instructions please ensure you leave them with the user.

## Contents

When you buy a Heritage product, you can be confident that it not only features a beautiful, distinctive, classic design, but that it has also been made to the very highest quality standards. To ensure that it works to its full potential, it needs to be fitted correctly. These fitting instructions have been created to give you all of the information you need and, if you need any further help, please do not hesitate to give us a call on **0844 701 8503**.

Important Safety Information	03
General Specifications	03
Dimensions	04
Installation	05-06
Maintenance	07
Troubleshooting	08
Notes	09
Guarantee	10-11





## Safety Note

- Please read these instructions & retain for future use. All products manufactured & supplied by Heritage are safe provided they are installed correctly, used correctly and receive regular maintenance in accordance with these instructions.
- **If you are in any doubt about your ability to install this product safely you must employ the services of an experienced qualified plumber.**



Before starting any installation please consider the following:

- Prior to drilling into walls, check there are no hidden electrical wires or cables or water supply pipes with the aid of an electrical detector.
- If you use power tools do not forget:
  - Wear eye protection.
  - Unplug equipment after use.
- This product must not be modified in any way as this will invalidate the guarantee.
- These fittings need to be installed in accordance with and meet the requirements of the Water Supply (Water Fittings) Regulations 1999 and Scottish Byelaws 2004.

## General Specification

Operating pressure range (bar)	Min	Max
THPCI0	0.2	5.0
THPCI1	0.2	5.0
Maximum static pressure – 10.0 bar		

**NOTE:-** Nominally equal (balanced) inlet supply pressures are recommended for optimum Performance of mixer taps.

Designed to comply with BS EN 200 for single taps / combination taps for water systems of type 1 and 2 general technical specifications; and to be used within systems designed to BS 6700.

BS 6700 recommends the temperature of stored water should never exceed 65°C. A stored water temperature of 60°C is considered sufficient to meet all nominal requirements and will minimise the build up of lime scale in hard water areas.



## Dimensions

### 3 Hole Wall Mounted Basin Mixer

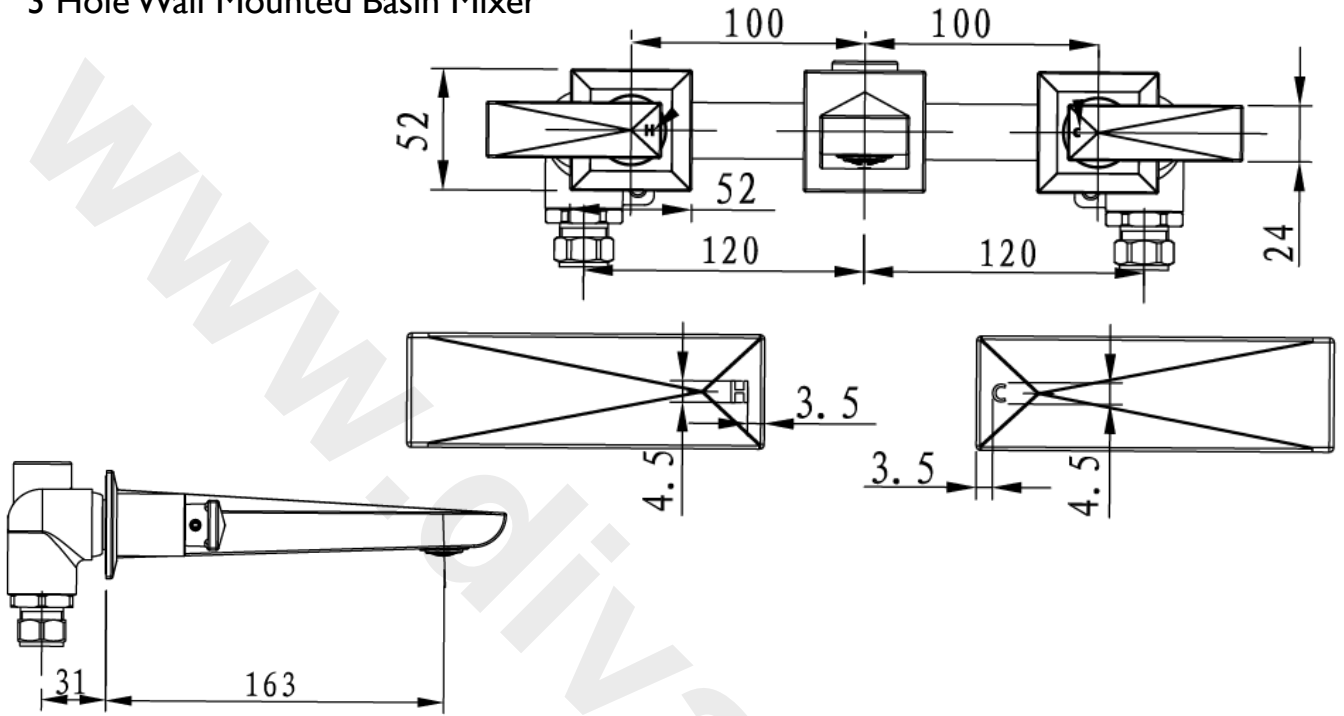

### 3 Hole Wall Mounted Bath Filler

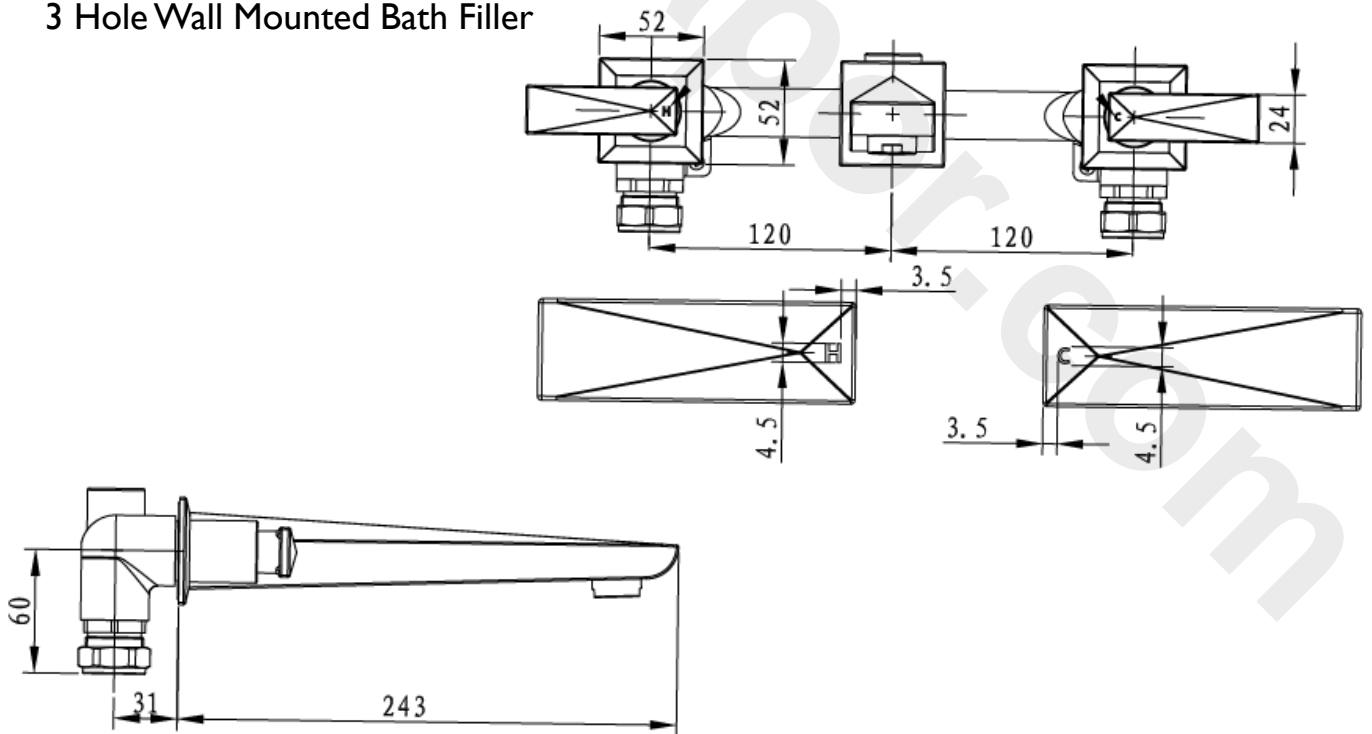



# Installation

## 3 Hole wall Mounted Basin Mixer & Bath Filler

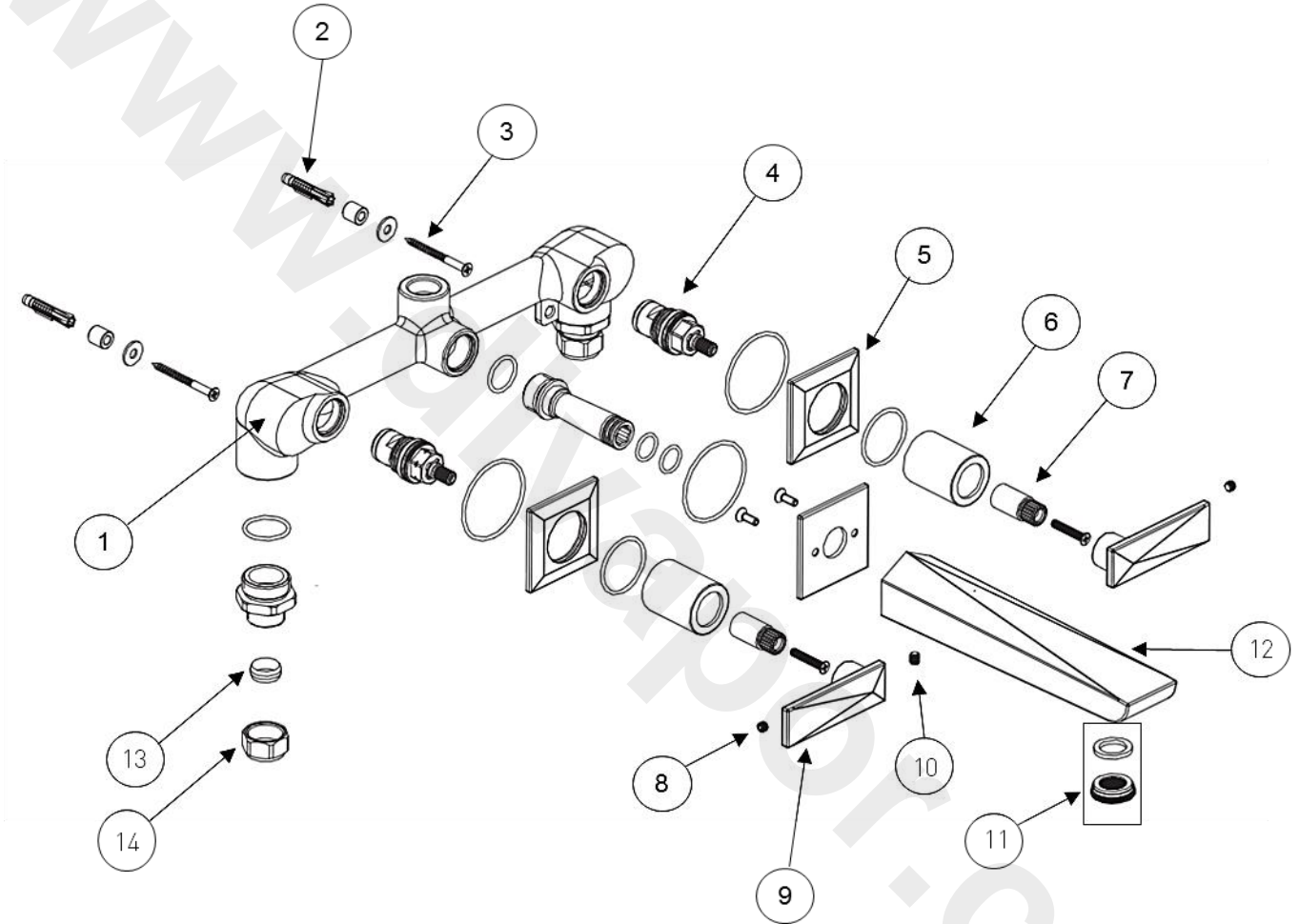

1. Body	x1	8. Handle Grub Screw	x2
2. Wall Plug	x2	9. Handle	x2
3. Screw	x2	10. Spout Grub Screw	x2
4. Valve	x2	11. Flow Straightener	x1
5. Plinth	x2	12. Spout	x1
6. Shroud	x2	13. Olive	x2
7. Spline Adaptor	x2	14. Compression Nut	x2



## Installation cont.

### 3 Hole Wall Mounted Basin Mixer & Bath Filler



Prior the drilling into walls, check there no hidden electrical wires, cables or water supply pipes with the aid of an electronic detector.

If you use power tools do not forget to:

- Wear eye protection
- Unplug equipment after use.

1. Identify all components are present prior to starting installation.
2. Decide on the final position of the basin mixer (1)
3. Plumb up the hot and cold supply pipes to the required position.
4. Attach pipework to the hot and cold inlets (hot on the left and cold on the right when viewed from the front) using a 1/2" BSP to 15mm connection (Not supplied).
5. Secure mixer body using the screws (3) and wall plugs (2).  
**Note:** Before finishing the wall turn on water supplies to check both correct mixer function and for leaking connections.
6. Set fitting into wall and complete wall surface.  
**Please note**, it is important that the spout (12) is not damaged and that sufficient thread is left exposed to allow the spout (12) and the valve shrouds (6) to fit.
7. Fit the spout (12) and tighten the grub screws (10) to secure in position.
8. Screw the valve shrouds (6) onto the valves (4) and push the plinth (5) onto the shroud (6). It maybe necessary to use a silicon sealant on the plinths to secure them into position.
9. Push the handles (9) onto the valve shrouds (6). Tighten the grub screw (8).
10. Check all joints and connections for leaks.





## Maintenance

### Cleaning the Valves:

If your fitting begins to leak the follow should be carried out:

Isolate both hot and cold water supplies to the tap by either:

- Turning the water supply off at the mains stopcock or
- Turning off the isolation valves to the tap

1. Unscrew the grub screw at the side of the handle and remove the handle.
2. Remove the plinth (if necessary) and then unscrew the shroud.
3. Unscrew the valve using a suitable spanner.
4. Lift out the valve and clean thoroughly. Be sure to check and clean out the seating within the mixer body.
5. If necessary replace the valve.
6. Place the valve back into the mixer body and tighten the valve fully using a suitable spanner.
7. Screw the shroud back onto the valve then push the plinth (if removed) onto the shroud and replace the handle. Tighten the grub screw.
8. Turn on water supply and check for leaks.
9. Contact our helpline if problem persists.

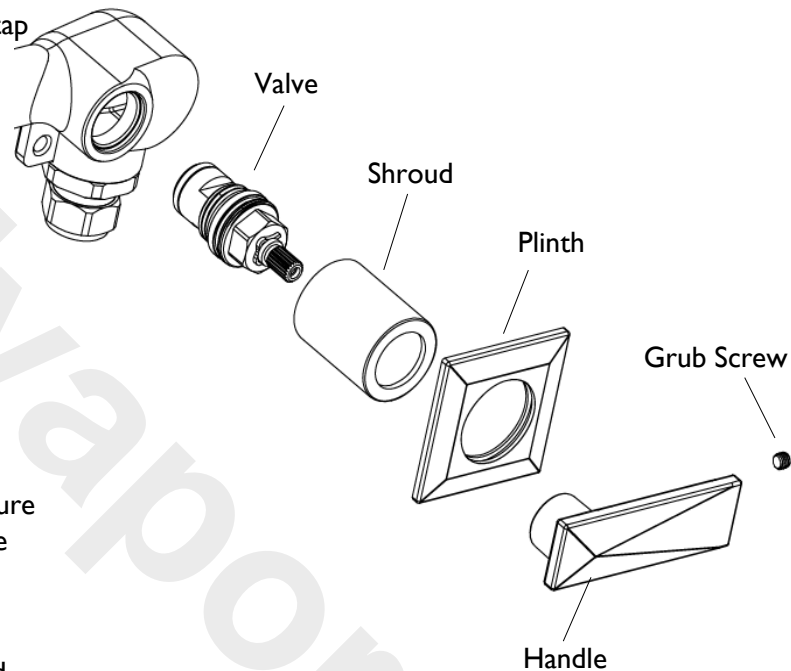

## Troubleshooting

Symptom	Cause	Remedy
No flow or poor flow rate.	Partially closed stop or service valve in water supply pipework to the tap.	Open stop or service valve.
	Head of water is below the minimum distance required.	Refer to the Specification section for minimum pressures required.
	Possible airlock / blockage in supply pipework	Remove water supplies from the fitting and flush the system to remove any airlocks / debris.
	Valve not opening fully.	Service fitting. Refer to maintenance section on page 7.
Water dripping for a few seconds after the tap has been turned off.	This is caused by 'capillary action' and residual water in the spout being siphoned out.	This should only last for a couple of seconds, and is normal after use.
Constant dripping / leaking when the tap is not in use.	Valve not fully shutting off.	Service fitting and replace valve. Refer to maintenance section on page 7.
Fitting does not turn on.	Water supplies not turned on.	Check that the water supplies to the fitting are turned on.
	Closed stop or service valve.	Open stop or service valve.
Water does not come out of the showerhead when using the bath shower mixer.	Diverter mechanism not fully open.	Pull the diverter out fully and twist to lock into position.
	Insufficient water pressure / header height.	Refer to the specification section for minimum pressures required.







## NOTES:

Please use this page to add any notes which you, or your installer may have regarding the installation / servicing of this product:

[www.divapor.com](http://www.divapor.com)



## Heritage Bathrooms Guarantee

When you buy a Heritage product, you can be confident that it not only features distinctive design, but that it has also been made to meet our rigorous quality standards.

We offer robust guarantees and an attentive aftercare service to ensure that if you do experience any issues, we can deal with a problem quickly, and effectively.

Please note that guarantees are only valid with proof of purchase.

Our guarantees are as follows:



2 Years on  
Mirrors &  
WC Seats



5 Years on  
Bath Screens,  
Furniture,  
Shower Valves,  
Taps, Wastes  
& Accessories



Lifetime Guarantee  
on Acrylic &  
Cast Iron Baths  
And Sanitaryware

## Register now for additional peace of mind

Register your product with us now and, if you do have any queries after installation, we'll be able to quickly identify the product and give you the best advice. It also means that you won't have to keep your proof of purchase to validate your guarantee. To register, simply go online at [www.heritagebathrooms.com/register](http://www.heritagebathrooms.com/register)

## Guarantee Terms and Conditions

This guarantee is in addition to your statutory and other legal rights and is subject to the following conditions:

- The product was purchased within the United Kingdom or Republic of Ireland
- The product is used in domestic applications only
- The guarantee applies solely to the original purchaser with proof of purchase
- The installation must allow ready access to all products for the purpose of inspection, maintenance or replacement
- Repair under this guarantee does not extend the original expiry date. The guarantee on any replacement parts or product ends at the original expiry date

Any part found to be defective during the guarantee period will be replaced without charge, providing that the product has been installed in accordance with the instructions given in this guide and used as the manufacturer intended. If the product is no longer available, Heritage will endeavour to provide the nearest equivalent.





## Heritage Bathrooms Guarantee Cont.

The guarantee does not cover:

- Damage or defects caused by
  - General wear and tear (including special non-chrome finishes; components such as filters, seals, 'O' rings and washers)
  - Incorrect installation
  - Repair using non-Heritage parts
  - Accidental or wilful misuse
  - Corrosion and the use of inappropriate cleaning products.
  - System debris including the build-up of limescale (which can be controlled through regular servicing and maintenance)
- Compensation for loss of use of the product or consequential loss of any kind.

In the interests of continuous product improvement, Heritage reserves the right to alter product specifications without notice.

### Need help?

In the unlikely event that you encounter a problem with your Heritage product, you must, in the first instance, contact the retailer you purchased it from. They will advise as to whether it is due to a manufacturing fault or an installation fault. If the problem is due to a manufacturing fault, they will contact us to arrange a supply of a replacement product as soon as possible. To speak to a Heritage customer service advisor, please contact our technical helpline on **0844 701 8503**.





HERITAGE®  
BATHROOMS

Heritage Bathrooms  
Birch Coppice Business Park  
Dordon  
Tamworth  
B78 1SG

Website: [www.heritagebathrooms.com](http://www.heritagebathrooms.com)

Telephone: 0844 701 8503

Email: [technical@heritagebathrooms.com](mailto:technical@heritagebathrooms.com)

HFI (HEMSBY WM) REV. D2

